

3.7m x 4.3m (12.1' x 14.1') FLAT TOP GAZEBO

Installation and Operating Instructions – YM12900



IMPORTANT, RETAIN FOR FUTURE REFERENCE: READ CAREFULLY

08-29-2022

YARDISTRY®

Yardistry – North America
 Toll Free Customer Support:
 1.888.509.4382
info@yardistrystructures.com
www.yardistrystructures.com

Regular Hours: Mon - Fri, 8:30 am - 5:00 pm EST (excl. holidays)
 (For extended hours see our website)
 English and French Spoken

Patents Pending

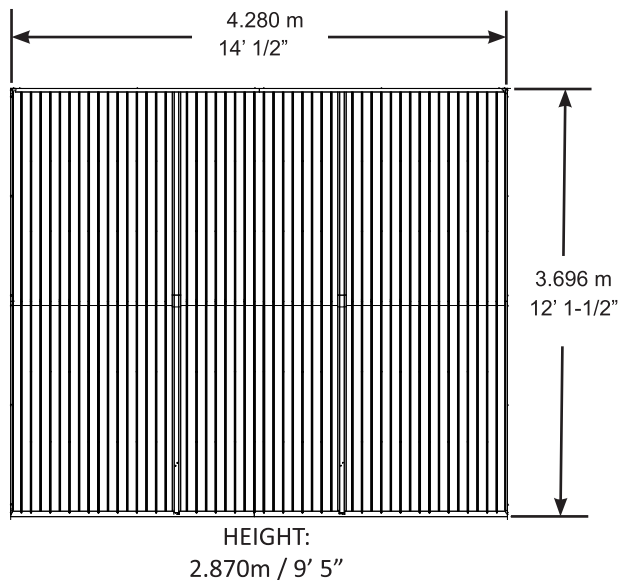

Important Safety Notice!

Yardistry components are intended for privacy, decorative and ornamental use only.

Product is NOT INTENDED for the following:

- A safety barrier to prevent unsupervised access to pools, hot tubs, spas or ponds.
- As load bearing support for a building, structure, heavy objects or swings.
- Used in structures that trap wind, rain or snow that would create extra load on the product.

Accumulated snow must be removed from roof.

DO NOT climb or walk on roof for any reason.

Permanent structures may require a building permit. As the purchaser and or installer of this product you are advised to consult local planning, zoning and building inspection departments for guidance on applicable building codes and/or zoning requirements.

Wood is NOT flame retardant and will burn. Grills, fire pits and chimineas are a fire hazard if placed too close to a Yardistry structure. Consult user's manual of the grill, fire pit or chiminea for safe distances from combustible materials.

Wear gloves to avoid injury from possible sharp edges of individual elements before assembly.

During installation, follow all safety warnings provided with your tools and use OSHA approved safety glasses. Some structures may require two or more people to install safely.

Check for underground utilities before digging or driving stakes into the ground!

During assembly it is important to closely follow the instructions. Complete the assembly on a solid, level surface and follow the instructions to square up, level and anchor the structure. This will reduce the gaps at wood connections during assembly.

General Information

General Information: Wood components are manufactured with Cedar (C. Lanceolata) which is protected with factory applied water-based stain. Knots, small checks (cracks) and weathering are naturally occurring and do not affect the strength of the product. Annual application of a water-based water repellent sealant or stain is important and will help reduce weathering and checks.

www.yardistrystructures.com

Questions?

Call toll free or write us at:
1 (888) 509-4382
support@yardistrystructures.com

Regular Hours: Mon - Fri, 8:30 am - 5:00 pm EST
(excl. holidays)
(For extended hours see our website)

English and French Spoken

Patents Pending

Limited Warranty

Yardistry warrants that this product is free from defect in materials and workmanship for a period of one (1) year from the original date of purchase. In addition, for any product with lumber, all lumber is warranted for five (5) years against rot and decay. This warranty applies to the original owner and registrant and is non-transferable.

Regular maintenance is required to assure the integrity of your product and is a requirement of the warranty. This warranty does not cover any inspection costs.

This Limited Warranty does not cover:

- Labour for replacement of any defective item(s);
- Incidental or consequential damages;
- Cosmetic defects which do not affect performance or integrity;
- Vandalism; improper use or installation; acts of nature, including but not limited to wind, storms, hail, floods, excessive water exposure;
- Minor twisting, warping, checking or any other natural occurring properties of wood that do not affect performance or integrity.

Yardistry products have been designed for safety and quality. Any modifications made to the original product could damage the structural integrity of the product leading to failure and possible injury. Yardistry cannot assume any responsibility for modified products. Furthermore, modification voids any and all warranties.

This product is warranted for RESIDENTIAL USE ONLY. Yardistry disclaims all other representations and warranties of any kind, express or implied.

This Warranty gives you specific legal rights. You may have other rights as well which vary from state to state or province to province. This warranty excludes all consequential damages, however, some states/provinces do not allow the limitation or exclusion of consequential damages, and therefore this limitation may not apply to you.

Instructions for Proper Maintenance

Your Yardistry structure is designed and constructed of quality materials. As with all outdoor products it will weather and wear. To maximize the enjoyment, safety and life of your structure it is important that you, the owner, properly maintain it.

HARDWARE:

- Check metal parts for rust. If found, sand and repaint using a non-lead paint complying with 16 CFR 1303.
- Inspect and tighten all hardware after completion of assembly; after first month of use; and then annually. Do not over-tighten as to cause crushing and splintering of wood.
- Check for sharp edges or protruding screw threads, add washers if required.

WOOD PARTS:

- Applying a water repellent or stain (water-based) on a yearly basis is important maintenance to maintain maximum life and performance of the product.
- Check all wood members for deterioration, structural damage and splintering. Sand down splinters and replace deteriorated wood members. As with all wood, some checking and small cracks in grain is normal.
- Some gapping may occur at some wood connections.

Assembly Guides

Tools Required:

- | | | |
|------------------------------|------------------|---------------------------|
| • Tape Measure | • 8' Step Ladder | • 6' Step Ladder x 2 |
| • Carpenters Level | • Safety Glasses | • Square |
| • Standard or Cordless Drill | • Adult Helper | • Ratchet |
| • Claw Hammer | • Safety Gloves | • 7/16, 1/2 & 9/16 Socket |
| • 7/16", 1/2" & 9/16" Wrench | • Hard Hat | |

Symbols:

Throughout these instructions symbols are provided in the top, right-hand corner of the page.



- Use Help, where this is shown, 2, 3 or 4 people are required to safely complete this step. To avoid injury or damage to the assembly make sure to get some help.



- Use a measuring tape to assure proper location



- Pre-drill a pilot hole before fastening screw or lag to prevent splitting of wood.

If you dispose of your Yardistry structure: Please disassemble and dispose of your unit so that it does not create any unreasonable hazards at the time it is discarded. Be sure to follow your local waste ordinances.

Assembly Tips

Following are some helpful tips to make the assembly process smooth and efficient.

PRE-ASSEMBLIES:

(i.e. Post and Beam Assemblies, Roof Rafter Assembly, etc)

- Work on a raised, solid and flat surface such as, a table or saw horse.
- Keep all connections flush where shown in the instructions.
- When assembling the beams keep parts flat, straight and snug when connecting.

METAL PARTS:

- Roofing material may have sharp edges, wear safety gloves.
- Remove all plastic covering, on both sides of the metal panels, directly before installing each piece.
- Place roofing material on a non-abrasive surface before and after assembly as it can bend, dent and scratch easily.
- The roofing screws can easily crush the roof panels and roof edges when using a power drill. We recommend hand tightening the roofing screws so they sit snug and tight to the roofing material.

Sealant Application Tips, Warning and First Aid Information

SEALANT:

- All surfaces to be clean, dry, dust and grease free before application with temperatures above 5°C (41°F), no warmer than 35°C (95°F).
- Remove cap and cut a small piece off the nozzle for a small bead.
- Apply sealant in small beads and smooth as required.
- To smooth sealant into the joint use a glove covered finger, putty knife, etc. Smooth sealant to create a continuous water-tight seal, diverting water into the gutter with an unimpeded flow into the gutter drain corner.
- Clean excess with a cloth or paper towel before it skins over.
- An initial bond will set in approximately 20 minutes and fully set in 24 hours.

WARNING:

- CAUSES SERIOUS EYE AND SKIN IRRITATION. Always wear safety glasses and rubber gloves when using product.
- KEEP OUT OF REACH OF CHILDREN.
- Prolonged or repeated exposure MAY CAUSE ORGAN DAMAGE. Provide ample ventilation.

FIRST AID:

- If ingested, DO NOT INDUCE VOMITING. Seek immediate medical attention.
- Eye contact: immediately flush eyes with water for at least 15 minutes. Remove contact lenses if present.
- Skin contact; wash thoroughly with soap and water. If eye/skin irritation persists or respiratory symptoms occur or develop, seek medical attention.

Use of this product can expose you to chemicals including Methanol, which is known to the State of California to cause birth defects and other reproductive harm. For more information, go to www.P65Warnings.ca.gov.

Dispose of contents and container in accordance with local regulations.

Permanent Installation Examples

Note: It is critically important you start with square, solid and level footings, concrete pad or deck to attach your Pergola Room.

We supply Post Mounts with this structure which gives you the flexibility to permanently install your structure to a pre-existing or new wood or concrete surface.

- The hardware to attach the Post Mount to the structure is included.
- The hardware to mount the structure permanently will need to be purchased separately at your local hardware store.

If you are mounting to concrete footers see below for the correct locations and placement. Please double check for possibility of any underground utilities such as gas, telephone, cable or sprinkler lines.

Following are some examples of how to mount the structure to wood or concrete surfaces.

Refer to your local building and city codes, ordinances, neighbourhood covenants, or height restrictions regarding this type of structure for guidance on acceptable installation requirements.

Concrete Footer

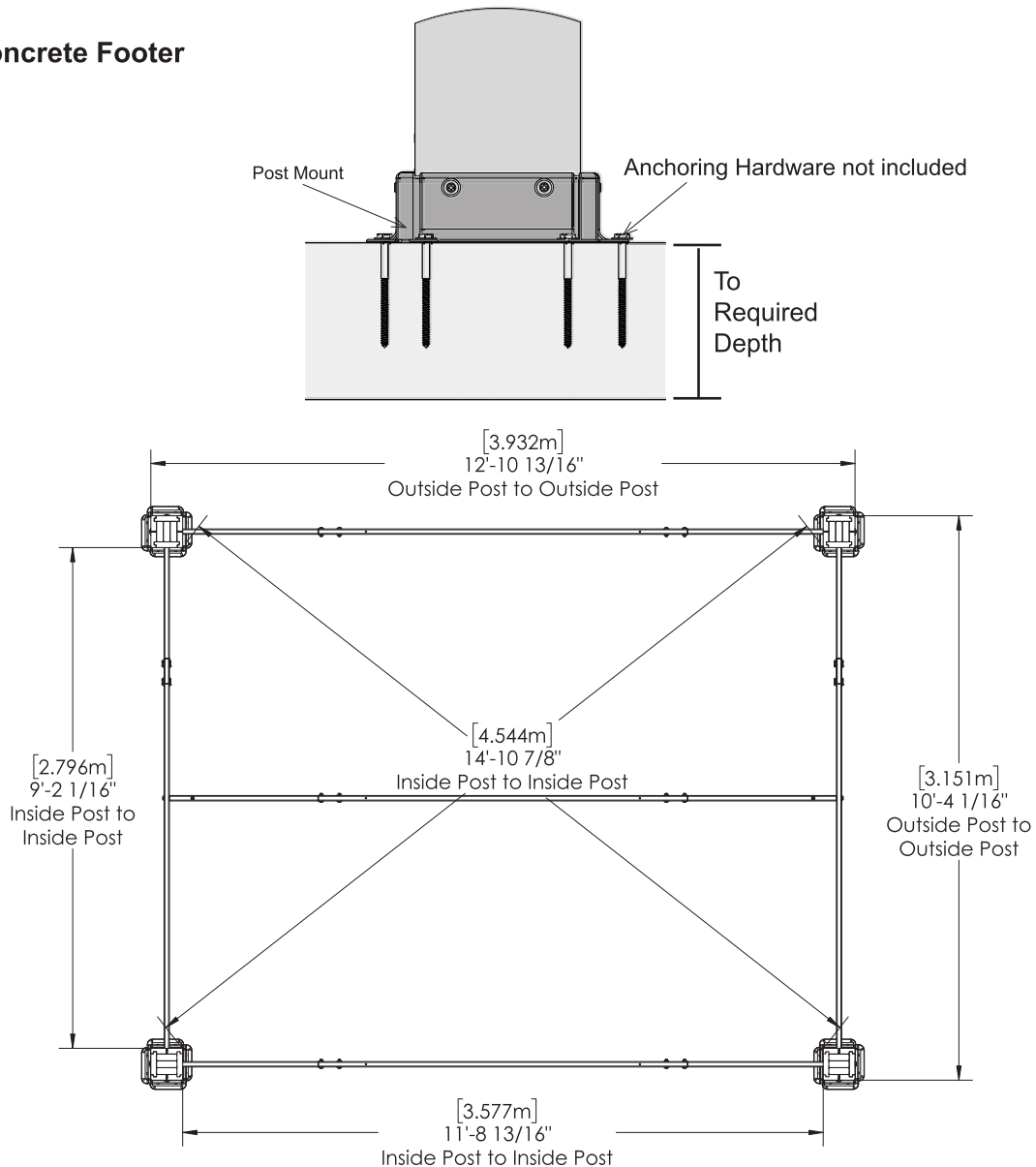

Permanent Installation Examples cont.

Concrete Patio [min. 3.456 m x 4.237 m (11' 4-1/16" x 13' 10-13/16")] with 15.24 cm (6") clearance on all sides

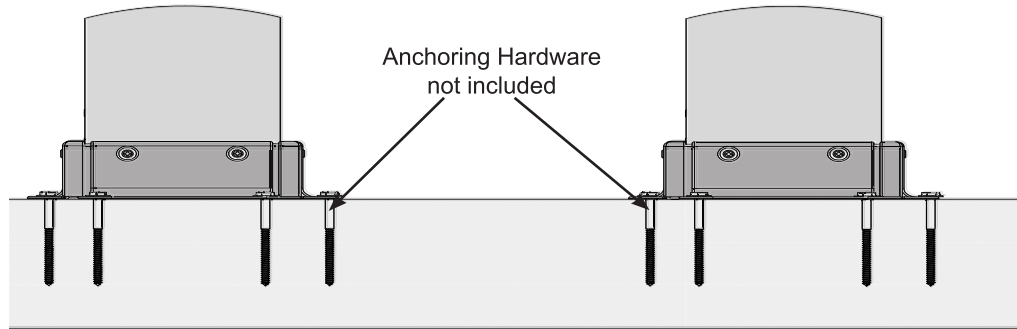

Wood Deck [min. 3.456 m x 4.237 m (11' 4-1/16" x 13' 10-13/16")] with 15.24 cm (6") clearance on all sides

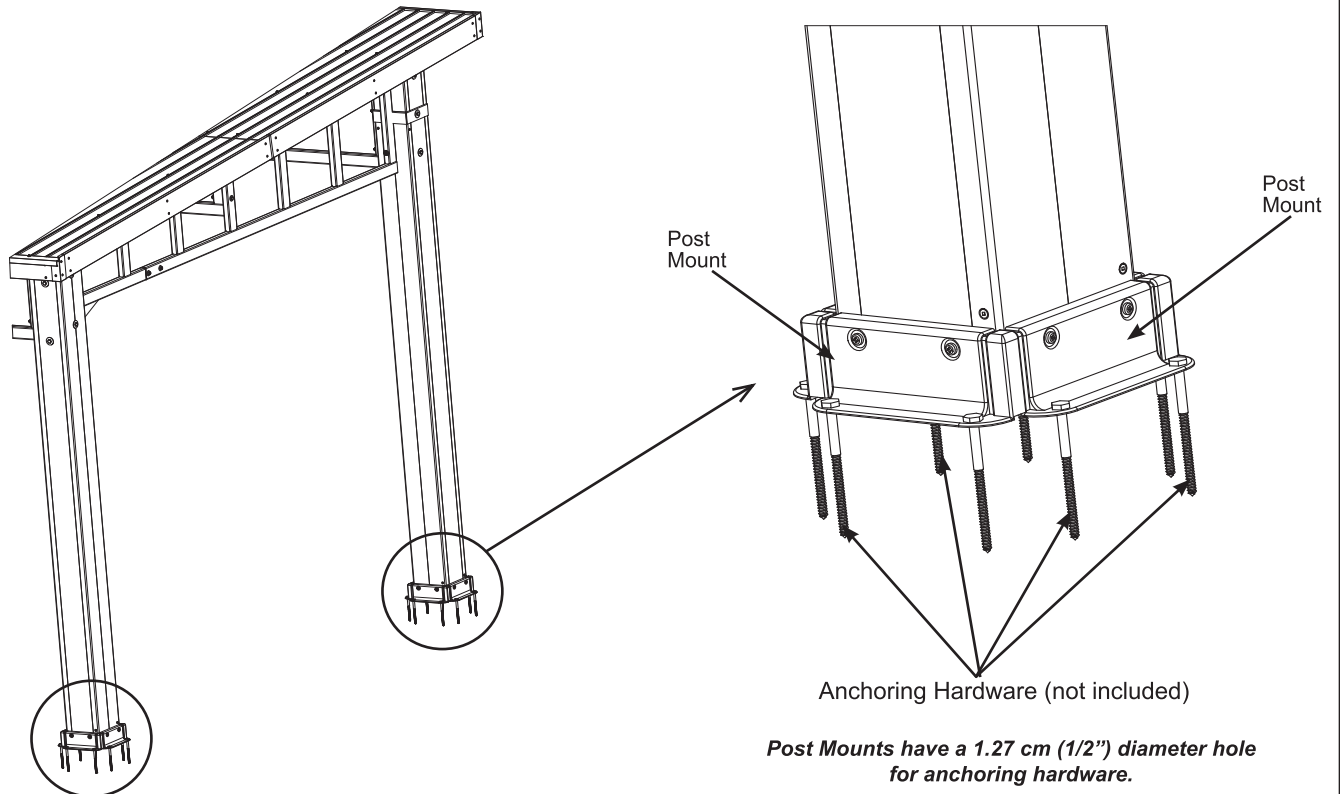
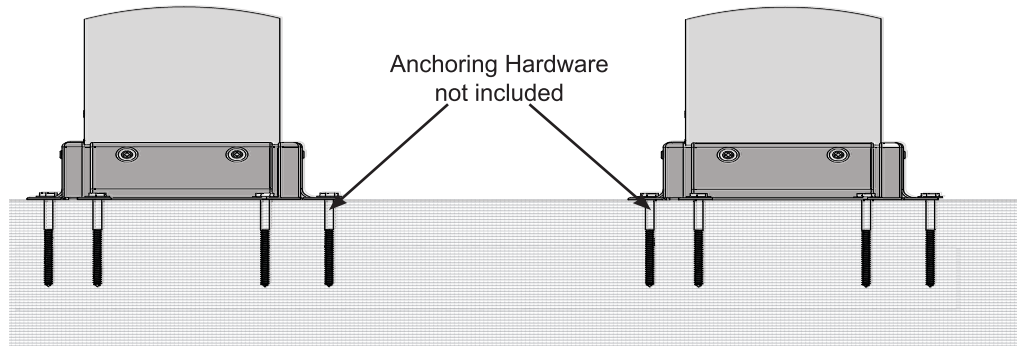

Part Identification (Dimensions are approximate and are shown to assist in the identification of parts for assembly. Actual dimensions may be smaller or larger.)

2pc. (1395) - Front Post Bottom 2455.5mm (96 11/16") FSC

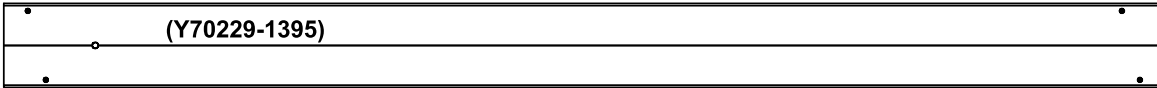

2pc. (1400) - Front Post Top 644.4mm (25 3/8") FSC

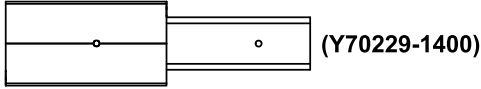

2pc. (1406) - Back Post 2534mm (99 3/4") FSC

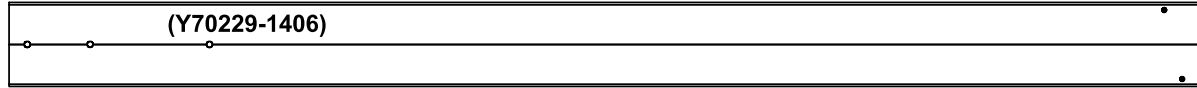

6pc. (1384) - Fascia 1422.4mm (56") FSC

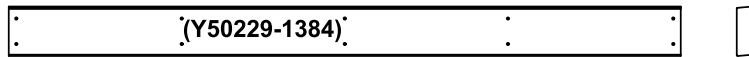

15pc. (1385) - Strap 1422.4mm (56") FSC

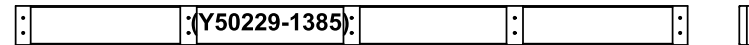

4pc. (1386) - Rafter Short Top B 1101.9mm (43 3/8") FSC

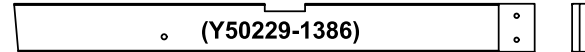

2pc. (1387) - Rafter Long Top B 2590.8mm (102") FSC

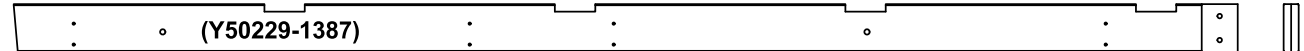

2pc. (1388) - Rafter Short Bottom B 1101.9mm (43 3/8") FSC

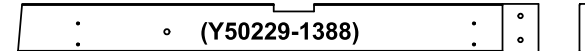

4pc. (1389) - Rafter Long Bottom B 2590.8mm (102") FSC

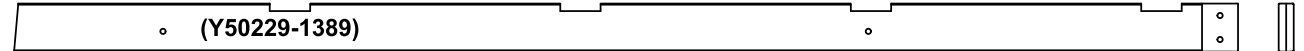

3pc. (1390) - Rafter Long Bottom A 2590.8mm (102") FSC

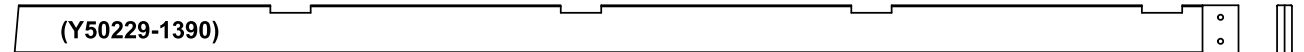

3pc. (1391) - Rafter Short Top A 1101.9mm (43 3/8") FSC

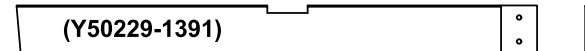

6pc. (1392) - Rafter Long Top A 2590.8mm (102") FSC



6pc. (1393) - Rafter Short Bottom A 1101.9mm (43 3/8") FSC



6pc. (1394) - Roof Eave Support 316.3mm (12 7/16") FSC



Part Identification (

Dimensions are approximate and are shown to assist in the identification of parts for assembly. Actual dimensions may be smaller or larger.)

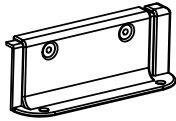

2 pc. Post Mount Plinth
(Y70818-546) (8PK)



1 pc. Truss Bracket
(Y70829-594) (8PK)

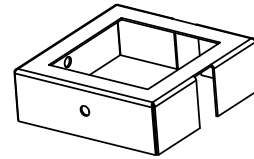

2 pc. Post Joint Cover
(Y00441-593)

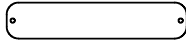

1 pc. Gazebo ID Plaque
(Y70800-104)

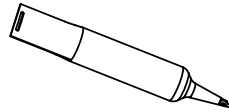

3 pc. Sealant Tube
(Y90100-001)

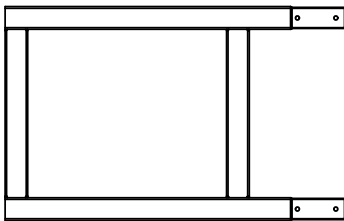

2 pc. Front Truss End Welded Assembly
(Y70841-573)

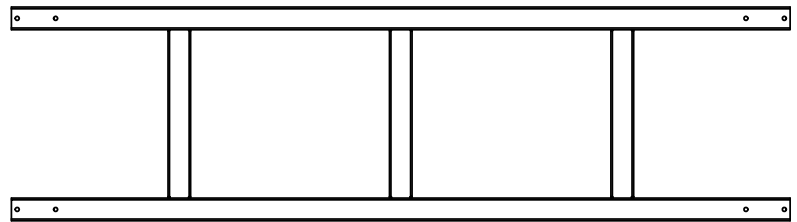

1 pc. Center Front Truss Welded Assembly
(Y70841-576)

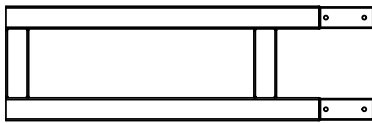

2 pc. Middle Truss End Welded Assembly
(Y70841-568)

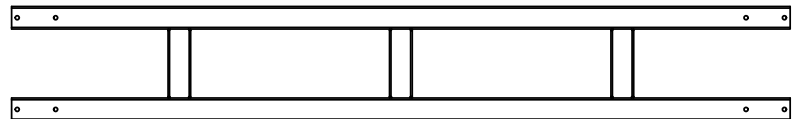

1 pc. Center Middle Truss Welded Assembly
(Y70841-572)

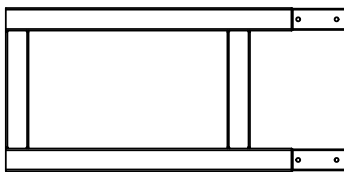

2 pc. Back Truss End Welded Assembly
(Y70841-562)

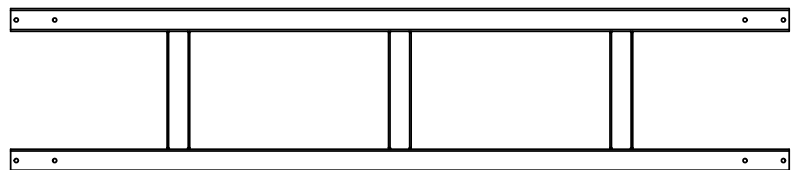

1 pc. Center Back Truss Welded Assembly
(Y70841-566)

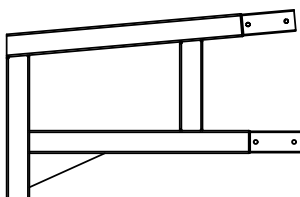

2 pc. Side Truss End Welded Assembly
(Y70841-555)

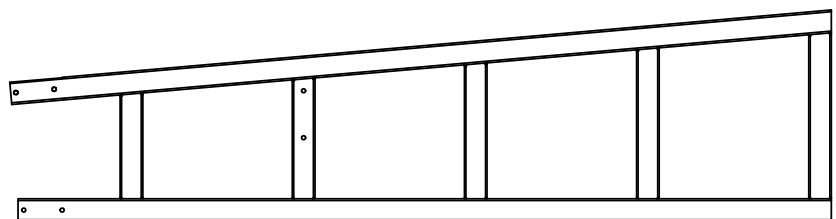

2 pc. Side Truss Welded Assembly
(Y70841-547)

Part Identification (Dimensions are approximate and are shown to assist in the identification of parts for assembly. Actual dimensions may be smaller or larger.)

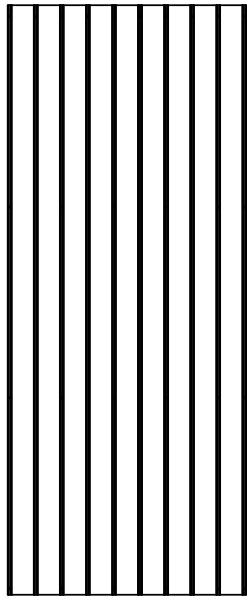

6 pc. Flat Roof Panel B
(Y01036-579)

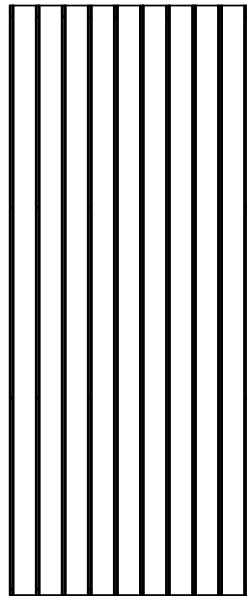

6 pc. Flat Roof Panel A
(Y01036-578)

1 pc. Flat Roof Gazebo Roof Panel Set
(Y70836-577)

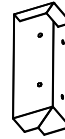

1 pc. Flat Roof Front Corner Cover - Right
(Y01036-589)

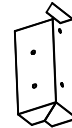

1 pc. Flat Roof Back Corner Cover - Right
(Y01036-587)



1 pc. Flat Roof Back Corner Cover - Left
(Y01036-588)

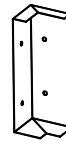

1 pc. Flat Roof Front Corner Cover - Left
(Y01036-590)

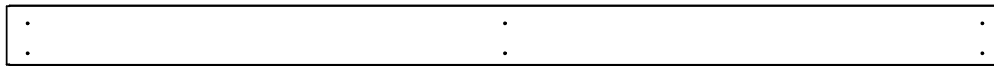

2 pc. Flat Roof Front Fascia Cover
(Y01036-584)

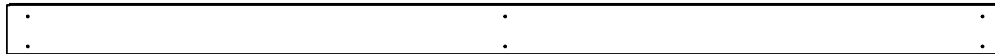

2 pc. Flat Roof Back Fascia Cover
(Y01036-585)

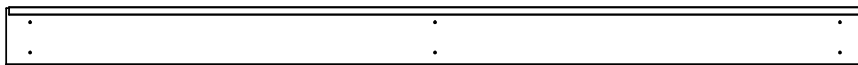

4 pc. Flat Roof Side Fascia Cover
(Y01036-586)



4 pc. Flat Roof Clip - Short
(Y01036-581)



4 pc. Flat Roof Clip - Long
(Y01036-580)

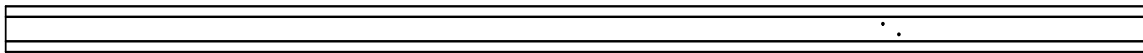

2 pc. Flat Roof Cap - Bottom
(Y01036-582)

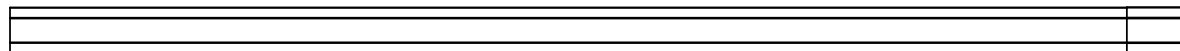

2 pc. Flat Roof Cap - Top
(Y01036-583)

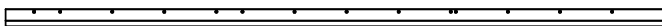

1 pc. Roof Back Edge - Right
(Y01036-592)

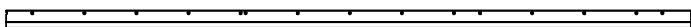

1 pc. Roof Back Edge - Left
(Y01036-591)

Hardware Identification (Dimensions are approximate and are shown to assist in the identification of parts for assembly. Actual dimensions may be smaller or larger.)

150pc. Wood Screw #8 x 1-1/2" (Y06091-512)



1pc. #2 x 2" Robertson Driver (Y00400-005)

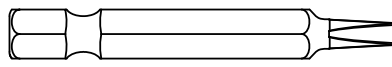

1pc. Hex Driver (Y00400-004)

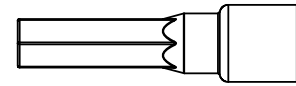

24pc. Wood Screw #8 x 2 1/4" - (Y06091-521)

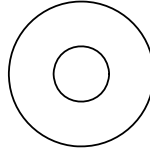

16pc. 1/4" Flat Washer (Y05118-201)

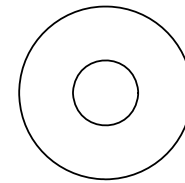

8pc. 5/16" Flat Washer (Y05118-203)

60pc. Wood Screw #8 x 2 1/2" - (Y06091-522)

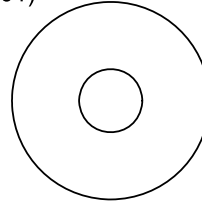

72pc. 5/16" Flat Washer, 1/8 Thick (Y05918-301)

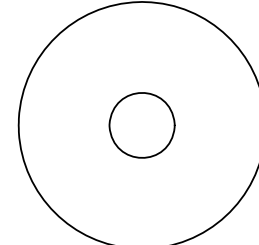

38pc. 1/4-5/16 x 1-1/4" Large Washer (Y05118-311)

12pc. Wood Screw #8 x 3 1/2" - (Y06091-532)



32pc. Pan Screw #12 x 2" - (Y06418-620)

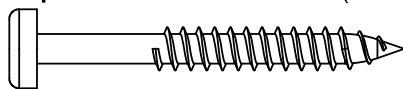

70pc. Sheet Metal Screw #8 x 3/4" - (Y06436-503)

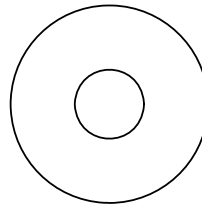

18pc. 3/8" Flat Washer (Y05118-801)

258pc. Hex Roofing Screw with Rubber Washer #8 x 1" (Y06736-510)

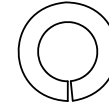

32pc. 5/16" Lock Washer (Y05318-300)

2pc. Lag Screw 5/16 x 3, 1/4" Shank - (Y06218-330)

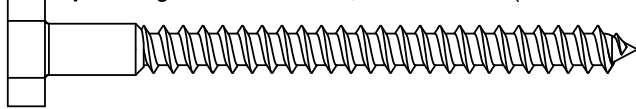

8pc. - 1/4" Lock Nut (Y08318-203)

8pc. Hex Bolt 1/4 x 3" - (Y07718-230)

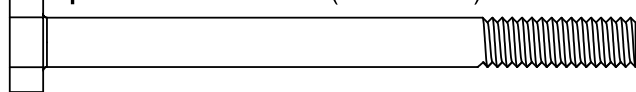

2pc. Hex Bolt 5/16 x 1-1/2" - (Y07718-312)

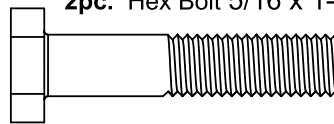

30pc. Hex Bolt 5/16 x 1-1/4" - (Y07718-311)

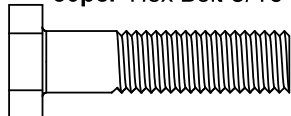

42pc. - 5/16" Lock Nut (Y08318-303)

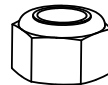

32pc. Hex Bolt 5/16 x 1-3/4" - (Y07718-313)

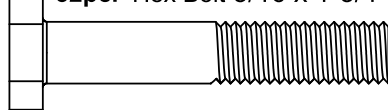

26pc. 3/8 x 1-1/4" Large Washer (Y05118-811)

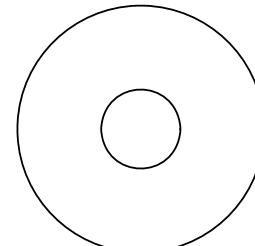

6pc. Hex Bolt 5/16 x 3-1/4" (Y07718-331)

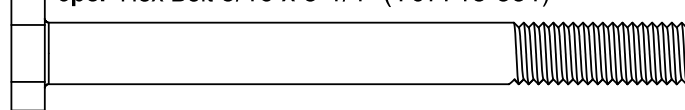

22pc. - 3/8" Lock Nut (Y08318-803)



4pc. Hex Bolt 5/16 x 4-1/4" (Y07718-341)

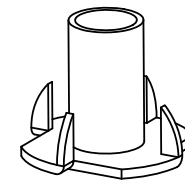
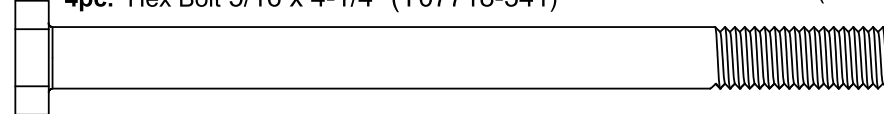

32pc. 5/16 - T-Nut (Y08518-300)

4pc. Hex Bolt 3/8 x 9" (Y07718-890)

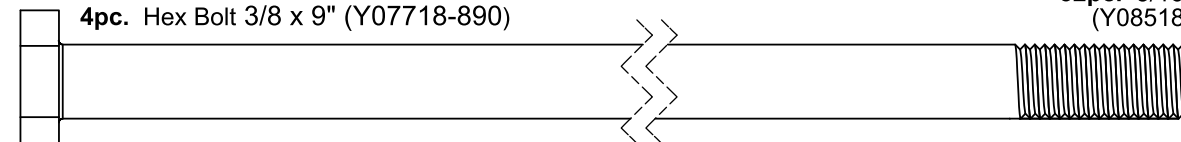

18pc. Hex Bolt 3/8 x 10" (Y07718-810)

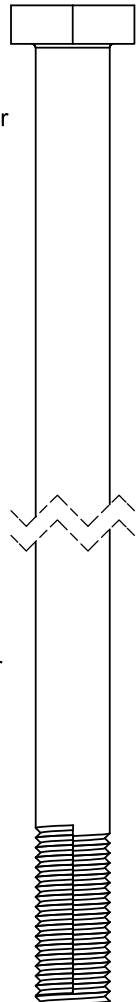

1pc. - 1/8" Drill Bit (Y00400-002)



Step 1: Inventory Parts - Read This Before Starting Assembly

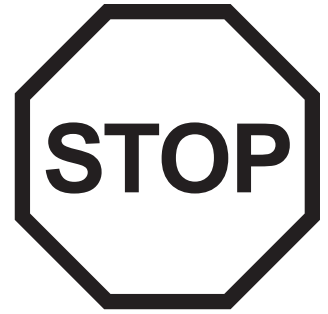
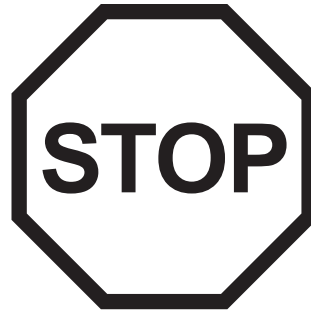
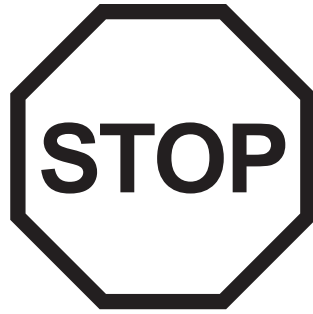

- A.** This is the time for you to inventory all your hardware, wood and accessories, referencing the parts identification sheets. This will assist you with your assembly.
- Each step indicates which bolts and/or screws you will need for assembly, as well as any flat washers, lock washers, t-nuts or lock nuts.
- B.** If there are any missing or damaged pieces or you need assistance with assembly please contact the consumer relations department directly. Call us before going back to the store.

1-888-509-4382
support@yardistrystructures.com

- C.** Read the assembly manual completely, paying special attention to ANSI warnings; notes; and safety/maintenance information on pages 1 - 4.
- Follow the instructions in order.
 - This structure is designed to be assembled and installed ideally by four people, DO NOT attempt to install alone.
 - Consider the slope of elevation where you plan to install the structure. Also, check for gas, telephone, other utilities or sprinkler line locations prior to excavating any holes.
- D.** Before you discard your cartons fill out the form below.
- The carton I.D. stamp is located on the end of each carton.
 - Please retain this information for future reference. You will need this information if you contact the Consumer Relations Department.

PRODUCT NUMBER: YM12900

CARTON I.D. STAMP: __ __ __ __ __ (Box 1)

CARTON I.D. STAMP: __ __ __ __ __ (Box 2)

CARTON I.D. STAMP: __ __ __ __ __ (Box 3)

CARTON I.D. STAMP: __ __ __ __ __ (Box 4)

Step 2: Post Assemblies

Part 1

A: At the bottom of two (1395) Front Post Bottoms place four Post Mount Plinths flush to the bottom of the post. Each post mount plinth should fit together in a tongue and groove style. Attach each Post Mount Plinth to posts with two #12 x 2" Pan Screws per post mount. (F2.1 and F2.2)

F2.1 Top

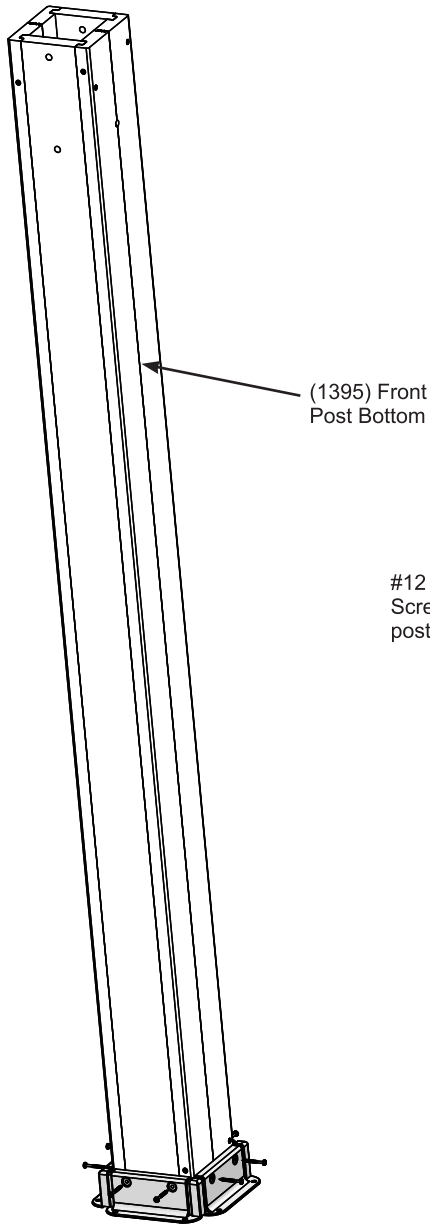

F2.2

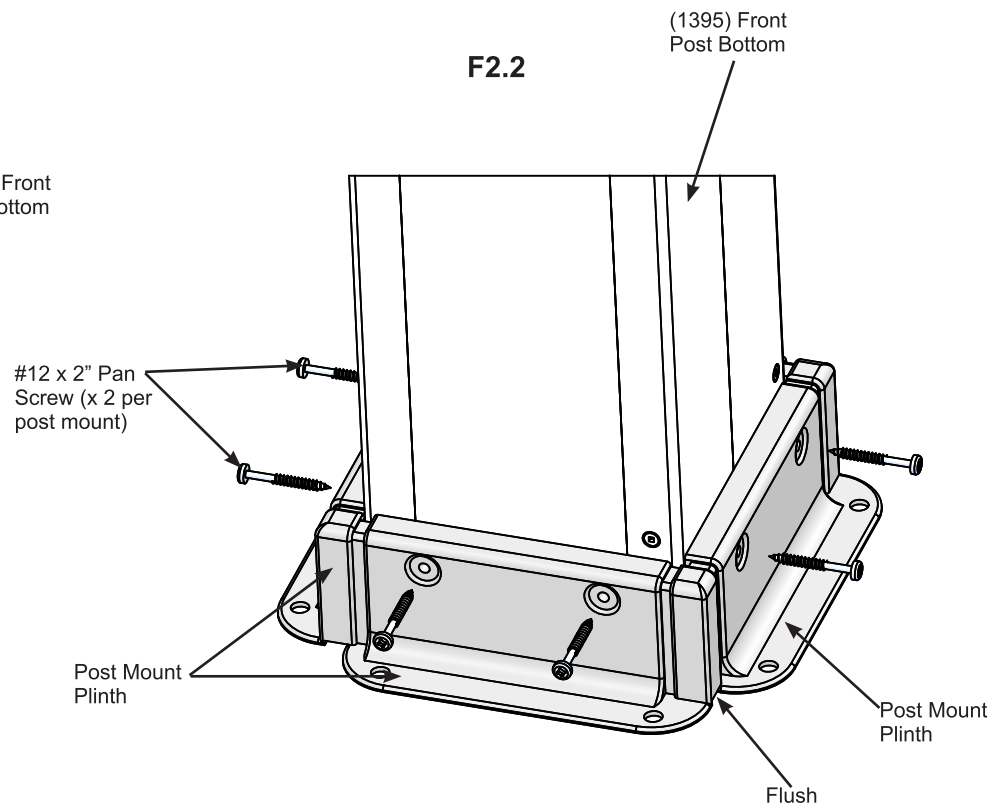

Wood Parts

2 x (1395) Front Post Bottom

Components

8 x Post Mount Plinth

Hardware

16 x #12 x 2" Pan Screw

Step 2: Post Assemblies Part 2

B: At the bottom of two (1406) Back Posts place four Post Mount Plinths flush to the bottom of the post. Each post mount plinth should fit together in a tongue and groove style. Attach each Post Mount Plinth to posts with two #12 x 2" Pan Screws per post mount. (F2.3 and F2.4)

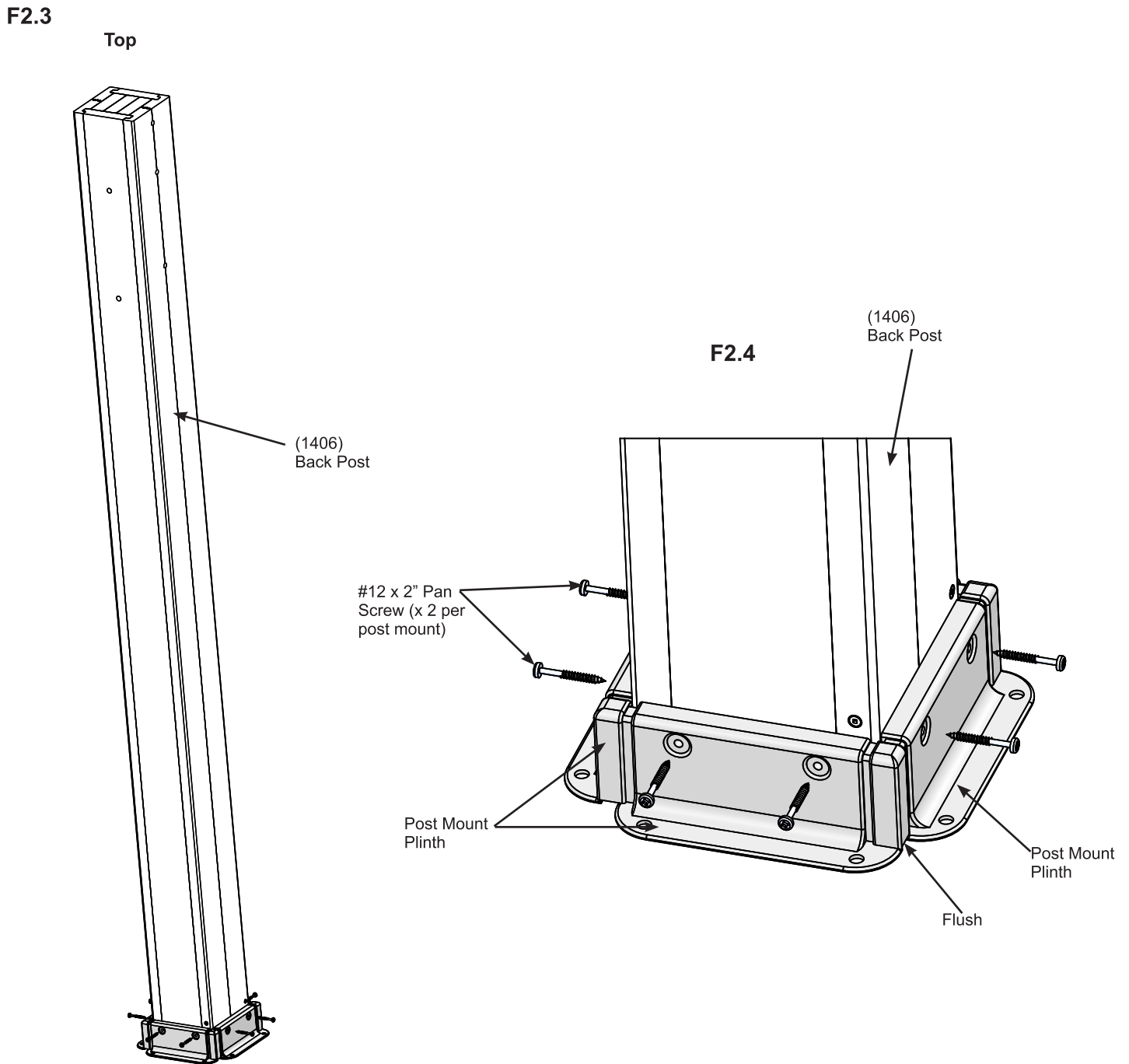

Wood Parts

2 x (1406) Back Post

Components

8 x Post Mount Plinth

Hardware

16 x #12 x 2" Pan Screw

Step 3: Front Right Post Assembly

A: Place one Post Joint Cover on top of (1395) Front Post Bottom with the right cutout over the two bolt hole side of the (1395) Front Post Bottom. (F3.1 and F3.2)

B: Insert the (1400) Front Post Top into the top of (1395) Front Post Bottom over the Post Joint Cover ensuring the holes align in the posts. (F3.3 and F3.4)

F3.1

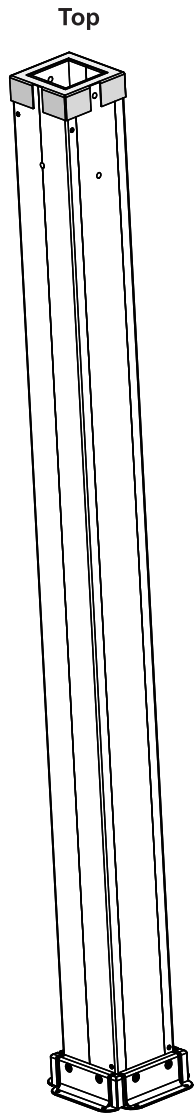

F3.2

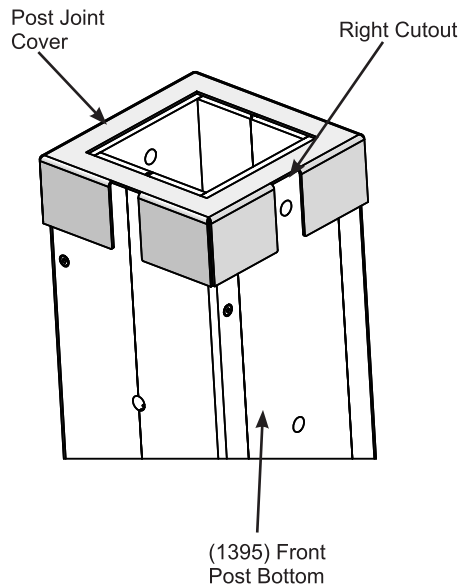

F3.3

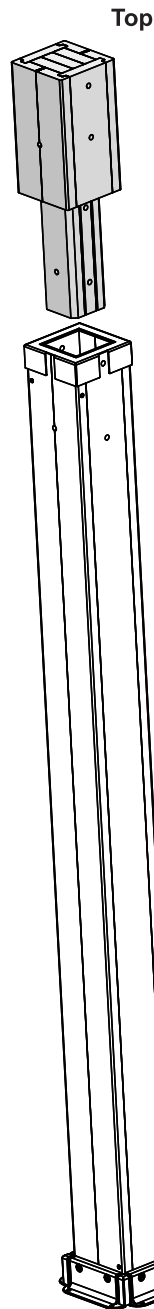

F3.4

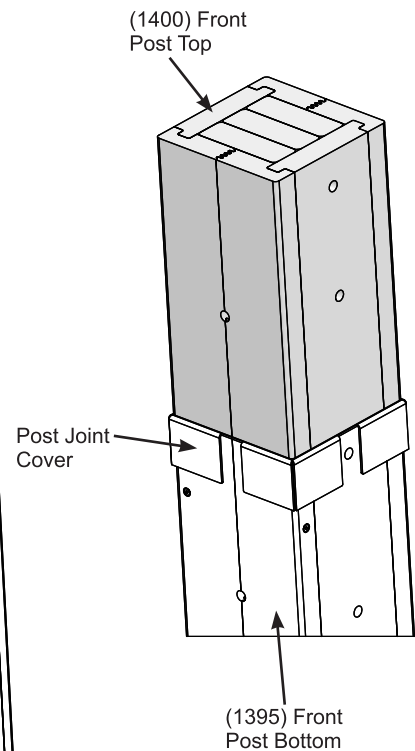

Wood Parts

1 x (1400) Front Post Top

Components

1 x Post Joint Cover

Step 4: Front Left Post Assembly

A: Place one Post Joint Cover on top of (1395) Front Post Bottom with the left cutout over the two bolt hole side of the (1395) Front Post Bottom. (F4.1 and F4.2)

B: Insert the (1400) Front Post Top into the top of (1395) Front Post Bottom over the Post Joint Cover ensuring the holes align in the posts. (F4.3 and F4.4)

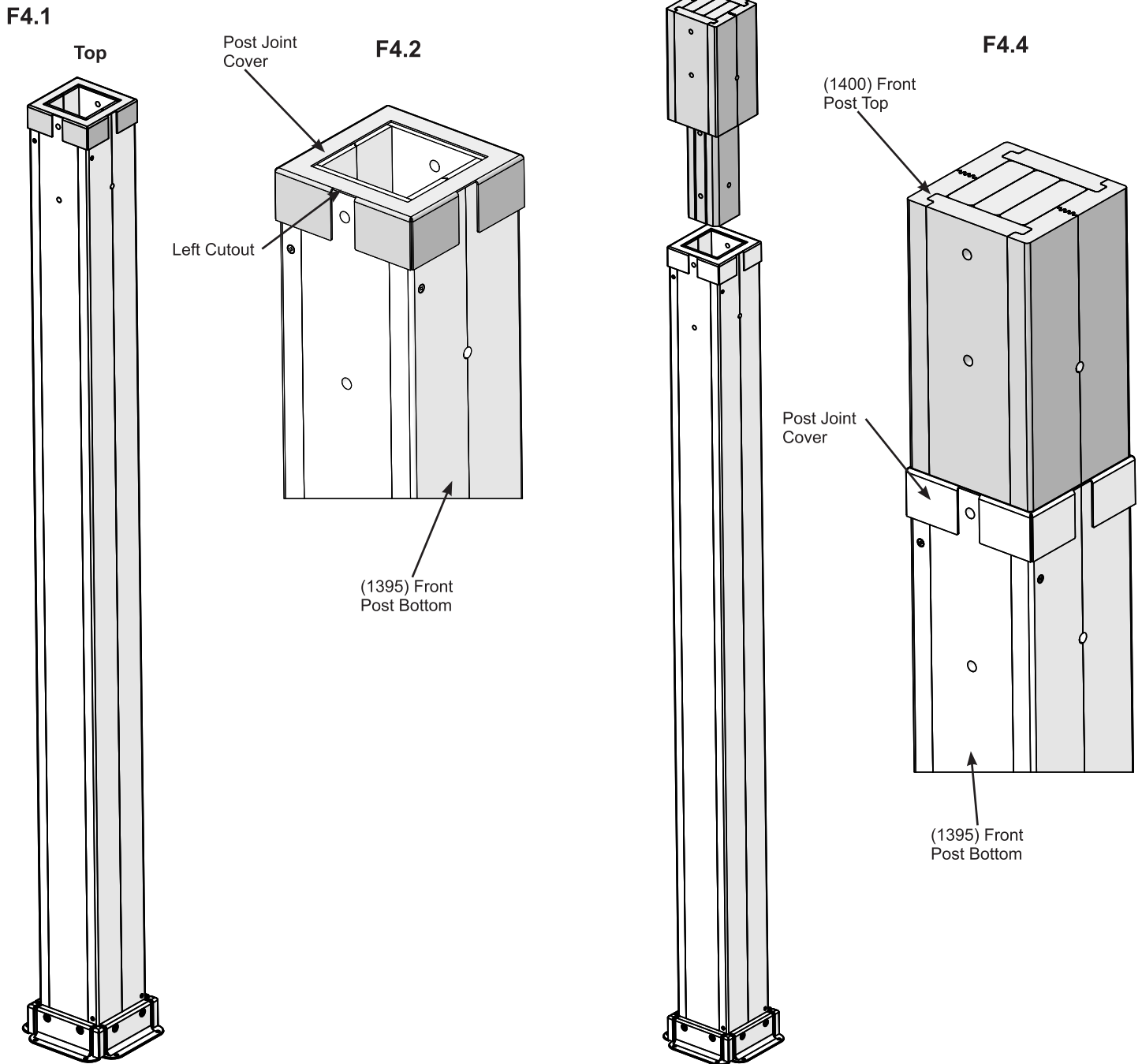

Wood Parts

1 x (1400) Front Post Top

Components

1 x Post Joint Cover

Step 5: Right Side Truss Assembly

A: Insert the Side Truss End Welded Assembly into the Side Truss Welded Assembly. Fasten together using four 5/16 x 1-3/4" Hex Bolts (with two 5/16" flat washer, 1/8" thick and one 5/16" lock nut) with the bolts inserted from the inside of the assembly. (F5.1 and F5.2)

F5.1

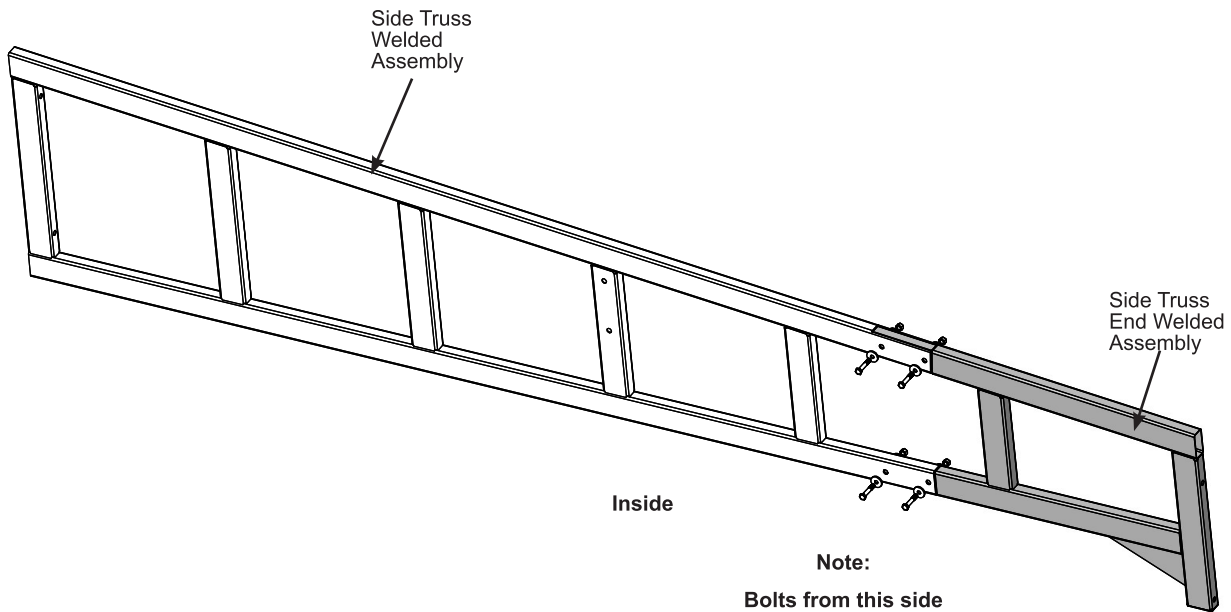

F5.2

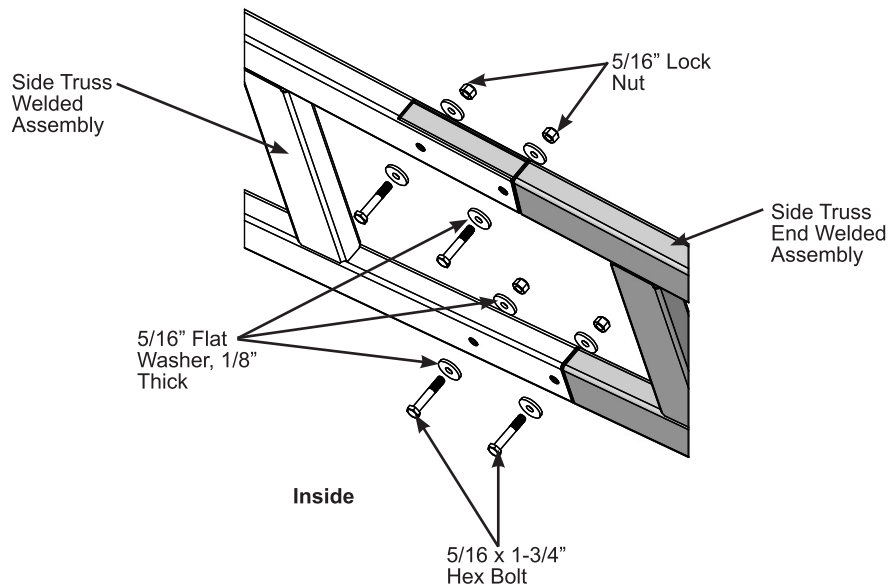

Components

- 1 x Side Truss Welded Assembly
- 1 x Side Truss End Welded Assembly

Hardware

- 4 x 5/16 x 1-3/4" Hex Bolt (5/16" flat washer, 1/8" thick x 2, 5/16" lock nut)

Step 6: Left Side Truss Assembly

A: Insert the Side Truss End Welded Assembly into the Side Truss Welded Assembly. Fasten together using four 5/16 x 1-3/4" Hex Bolts (with two 5/16" flat washer, 1/8" thick and one 5/16" lock nut) with the bolts inserted from the outside of the assembly. (F6.1 and F6.2)

F6.1

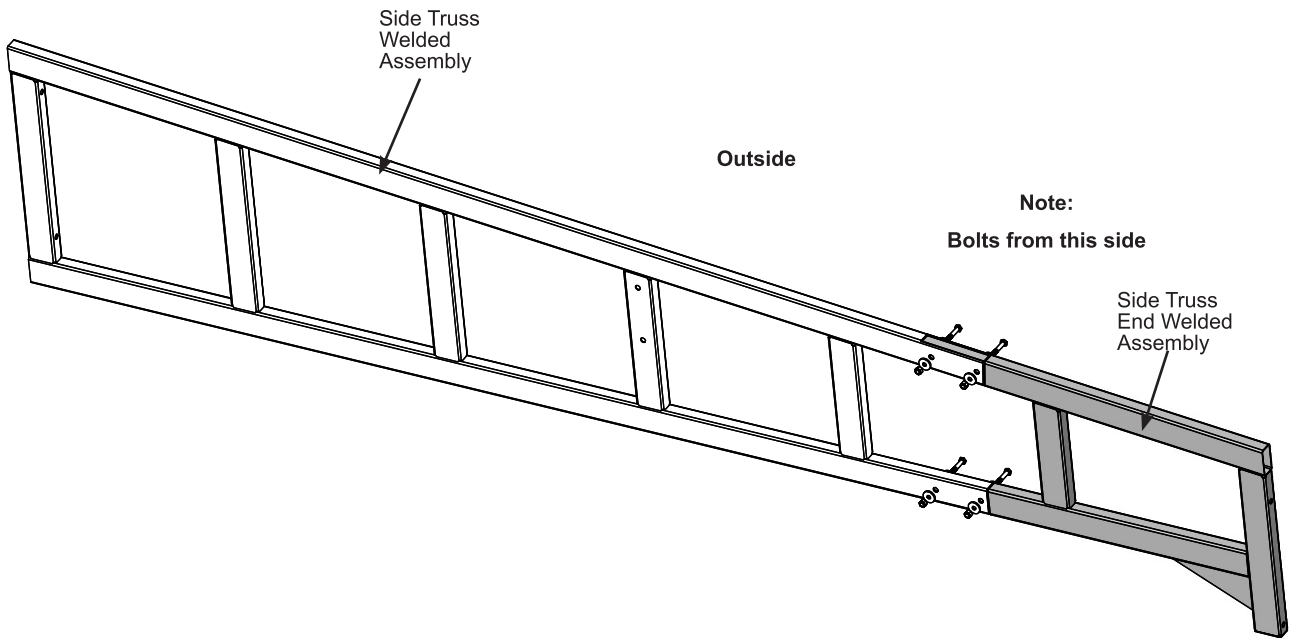

F6.2

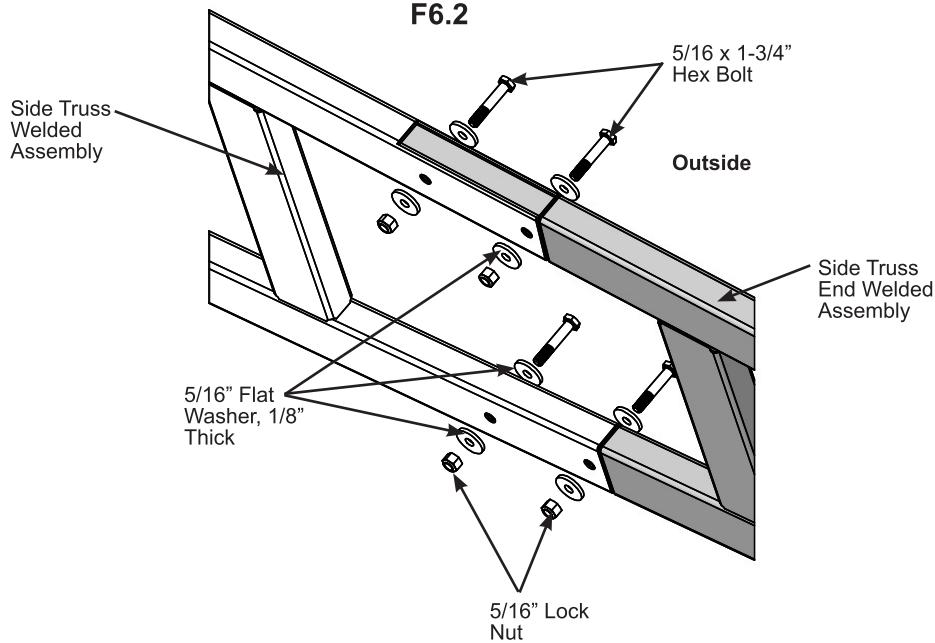

Components

1 x Side Truss Welded Assembly
1 x Side Truss End Welded Assembly

Hardware

4 x 5/16 x 1-3/4" Hex Bolt
(5/16" flat washer, 1/8" thick x 2, 5/16" lock nut)

Step 7: Front Truss Assembly

A: Insert one Front Truss End Welded Assembly into each side of the Center Front Truss Welded Assembly. Fasten together using four 5/16 x 1-3/4" Hex Bolts (with two 5/16" flat washer, 1/8" thick and one 5/16" lock nut) per end. (F7.1 and F7.2)

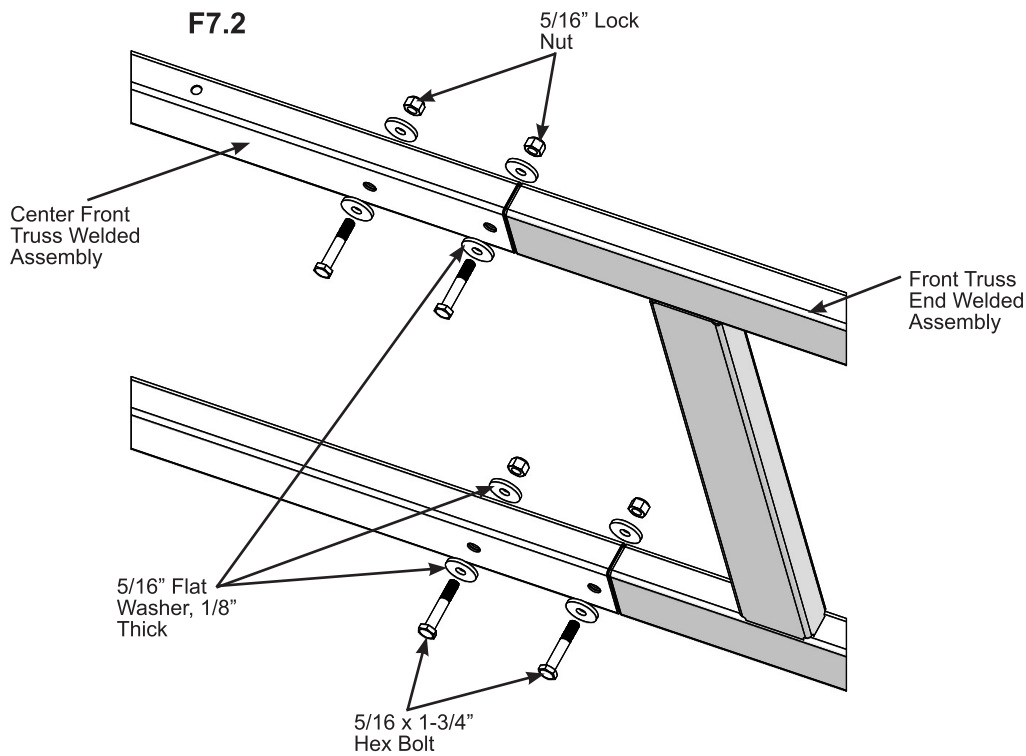
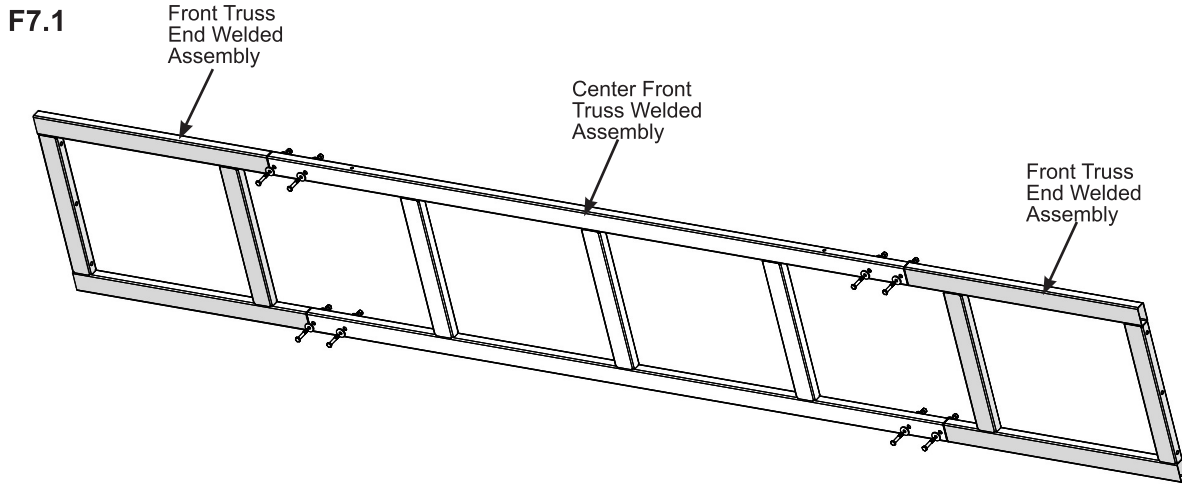

Components

1 x Center Front Truss Welded Assembly
2 x Front Truss End Welded Assembly

Hardware

8 x 5/16 x 1-3/4" Hex Bolt
(5/16" flat washer, 1/8" thick x 2, 5/16" lock nut)

Step 8: Back Truss Assembly

A: Insert one Back Truss End Welded Assembly into each side of the Center Back Truss Welded Assembly. Fasten together using four 5/16 x 1-3/4" Hex Bolts (with two 5/16" flat washer, 1/8" thick and one 5/16" lock nut) per end. (F8.1 and F8.2)

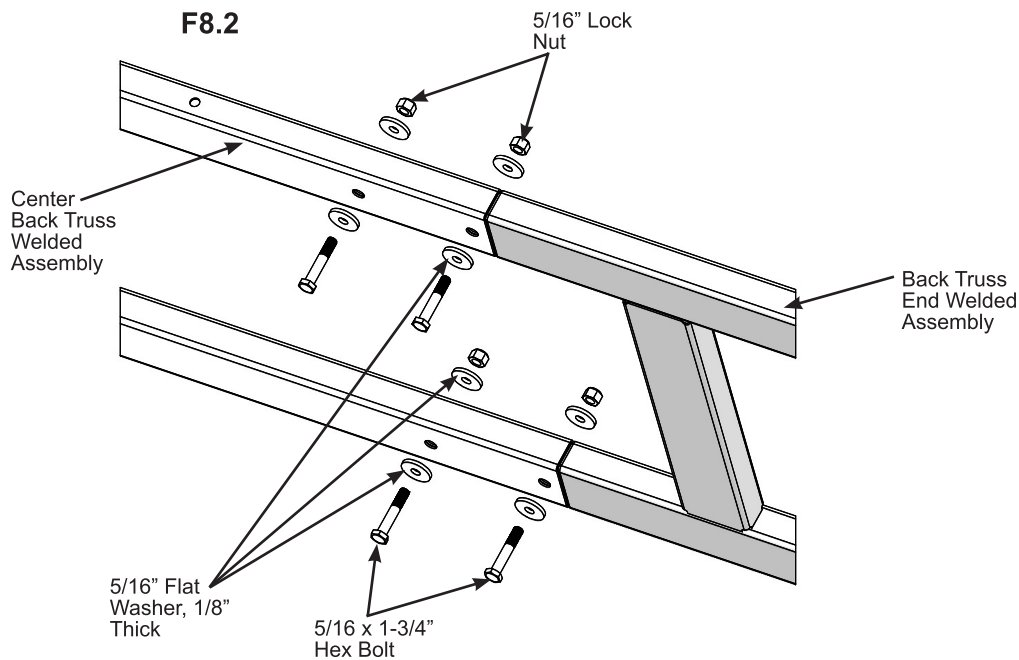
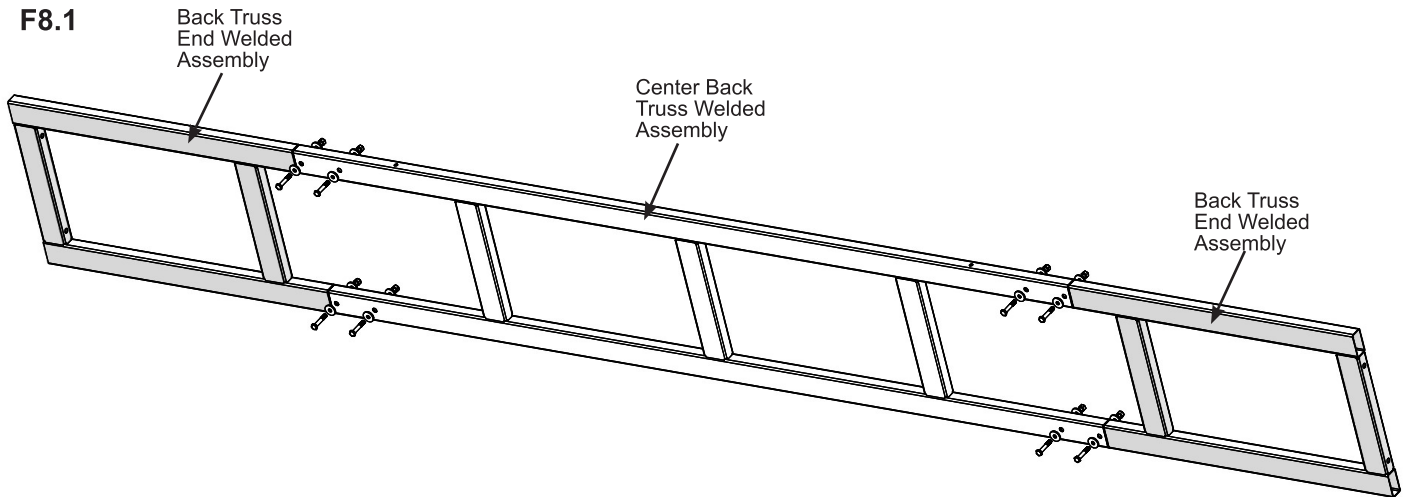

Components

1 x Center Back Truss Welded Assembly
2 x Back Truss End Welded Assembly

Hardware

8 x 5/16 x 1-3/4" Hex Bolt
(5/16" flat washer, 1/8" thick x 2, 5/16" lock nut)

Step 9: Middle Truss Assembly

A: Insert one Middle Truss End Welded Assembly into each side of the Center Middle Truss Welded Assembly with all holes on top. Fasten together using four 5/16 x 1-3/4" Hex Bolts (with two 5/16" flat washer, 1/8" thick and one 5/16" lock nut) per end. (F9.1 and F9.2)

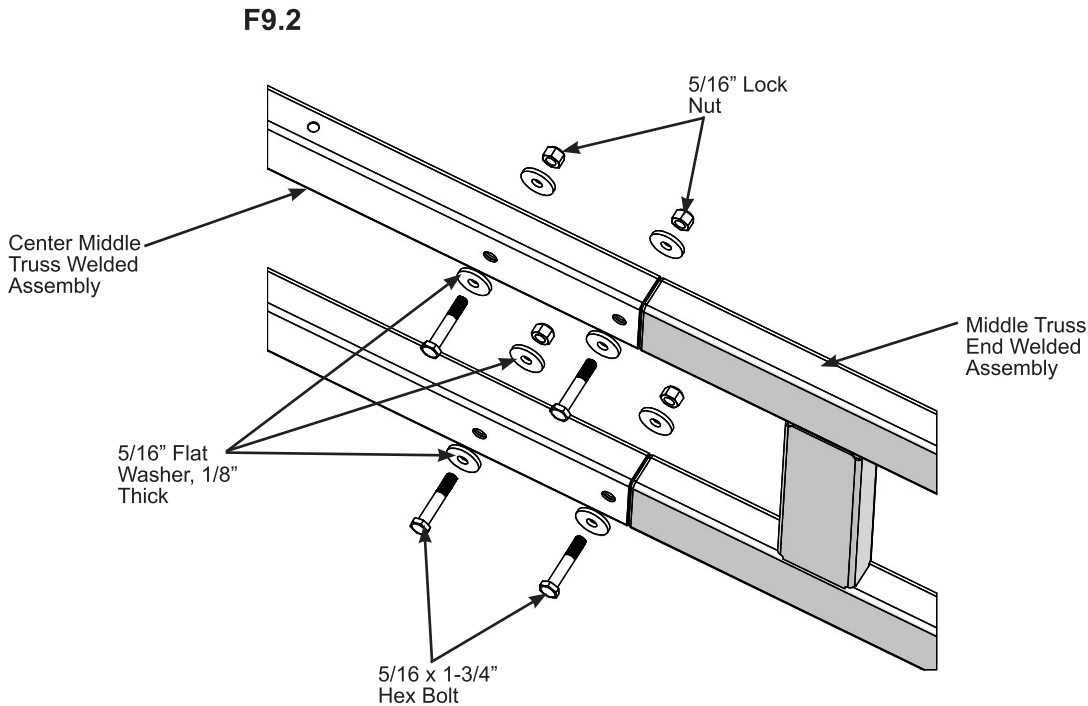
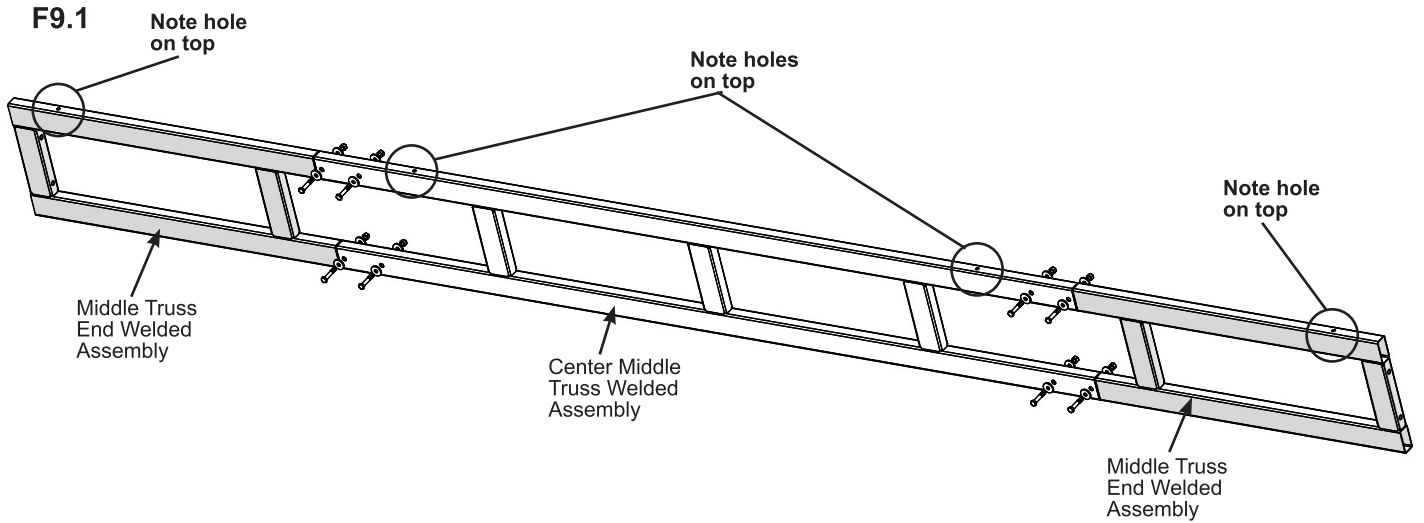

Components

1 x Center Middle Truss Welded Assembly
2 x Middle Truss End Welded Assembly

Hardware

8 x 5/16 x 1-3/4" Hex Bolt
(5/16" flat washer, 1/8" thick x 2, 5/16" lock nut)

Step 10: Front Frame Assembly



A: Place the Front Truss Assembly between the Front Right Post Assembly and Front Left Post Assembly, in the cutouts of the Post Joint Cover. Ensure the holes in the Front Truss Assembly are on top and the lock nuts on the inside. Attach Front Truss Assembly to Posts using three 3/8 x 10" Hex Bolts (with one 3/8" large washer, one 3/8" flat washer and one 3/8" lock nut) per Post. (F10.1 and F10.2)

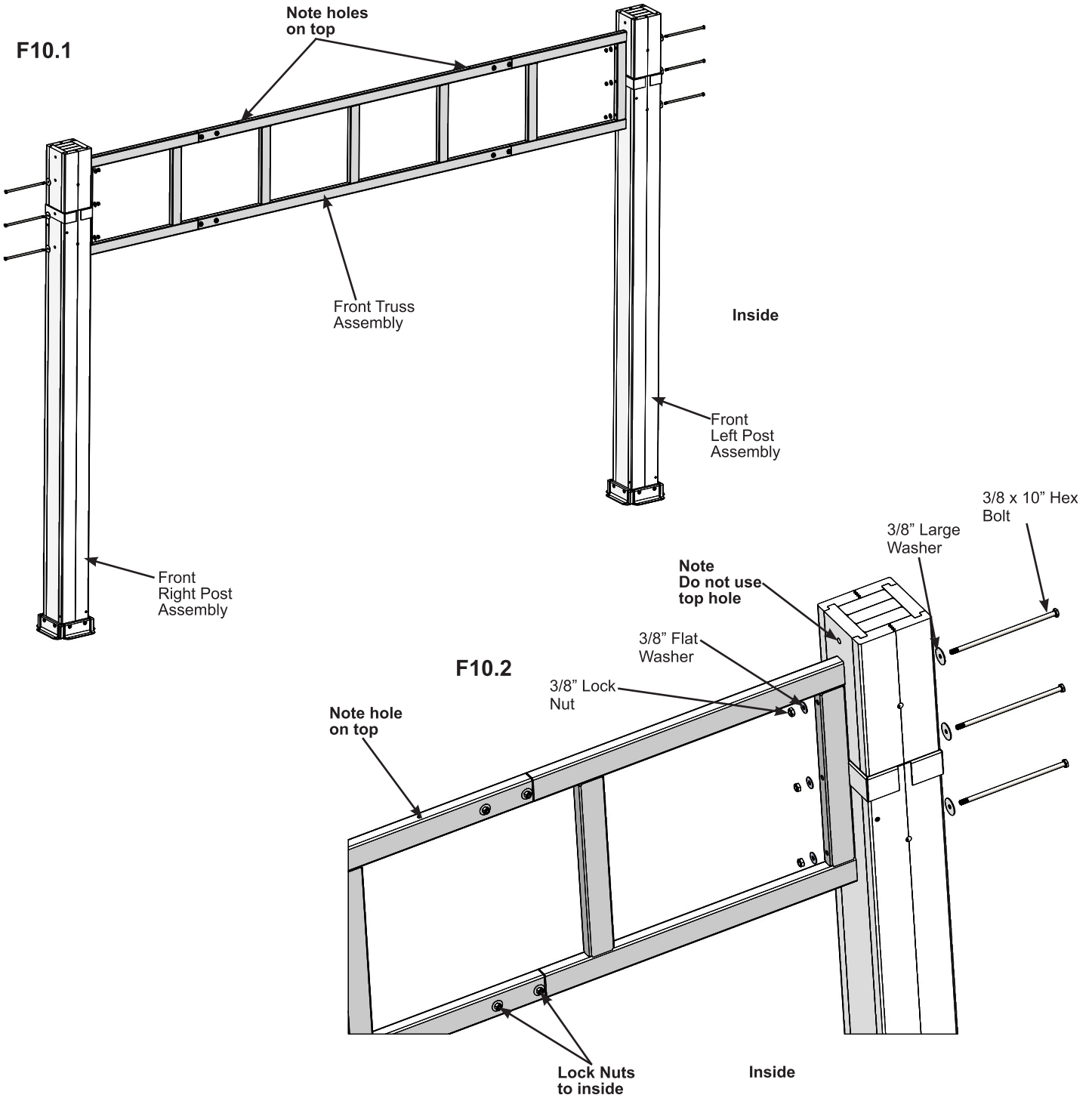

Hardware

6 x 3/8 x 10" Hex Bolt
(3/8" large washer, 3/8" flat washer and 3/8" lock nut)



Step 11: Back Frame Assembly

A: Place the Back Truss Assembly between two Back Post Assemblies with the holes in the Back Truss Assembly on top. Attach Back Truss Assembly to Posts using two 3/8 x 10" Hex Bolts (with one 3/8" large washer, one 3/8" flat washer and one 3/8" lock nut) per Post, on the side of the post with three holes. (F11.1 and F11.2)

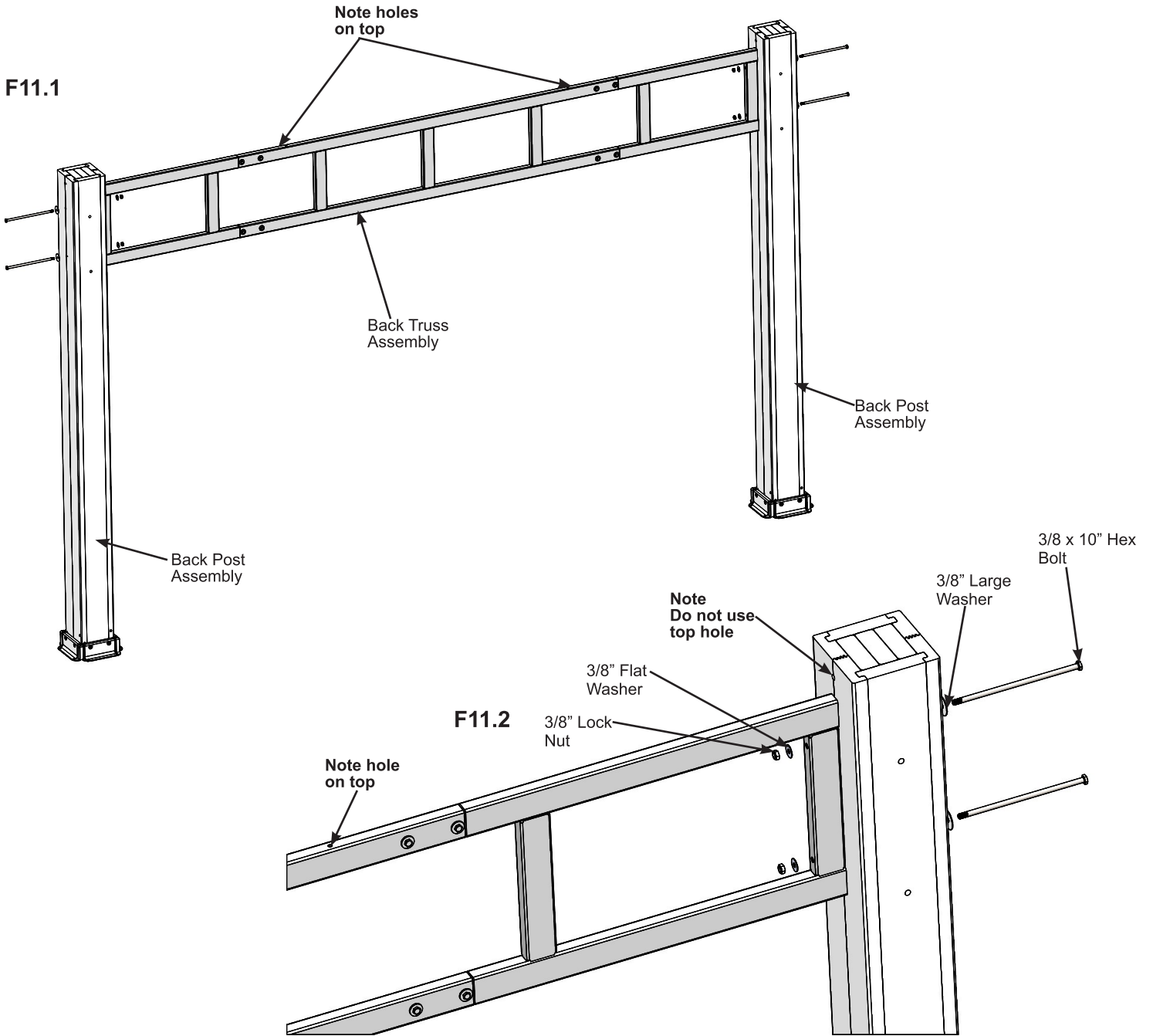

Hardware

4 x 3/8 x 10" Hex Bolt
(3/8" large washer, 3/8" flat washer and 3/8" lock nut)

Step 12: Frame Assembly

Part 1

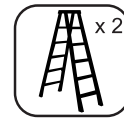

A: Move your Post Assemblies to the final location. Make sure the ground is flat and level before continuing assembly.

B: With adult helpers stand up the Front Frame Assembly and Back Frame Assembly then place Left Side Truss Assembly on the left side and the Right Side Truss Assembly on the right side. (F12.1)

All bolt heads in the trusses should be facing the outside.

C: Attached Side Trusses to Posts using two 3/8 x 10" Hex Bolt (with one 3/8" large washer, one 3/8" flat washer and one 3/8" lock nut) per Post. (F12.1, F12.2 and F12.3)

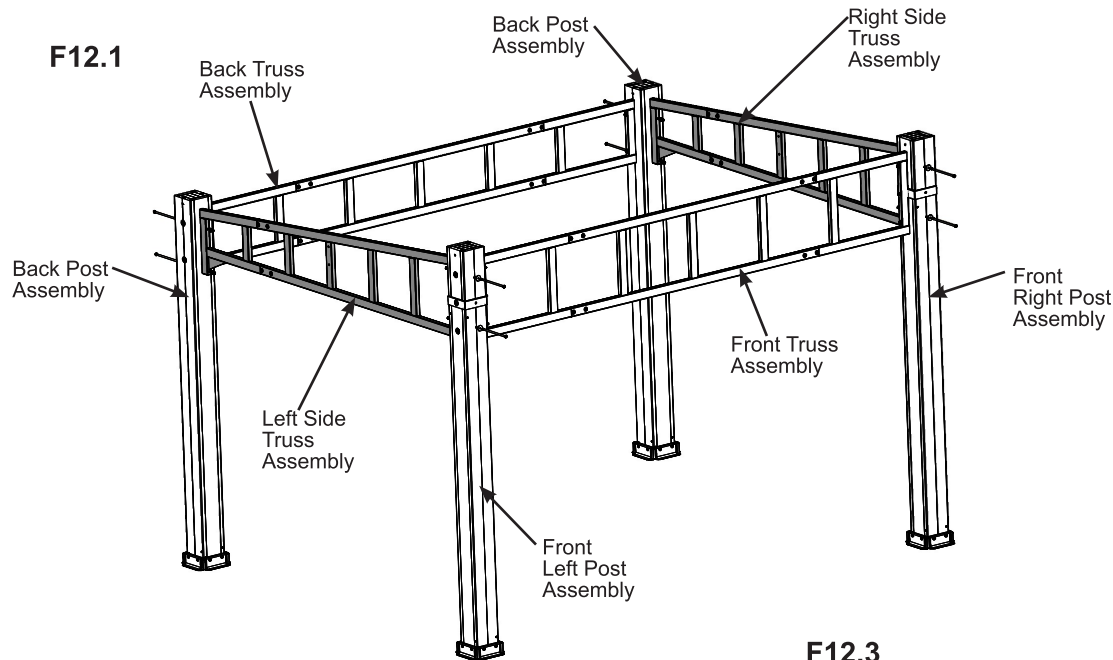

F12.2

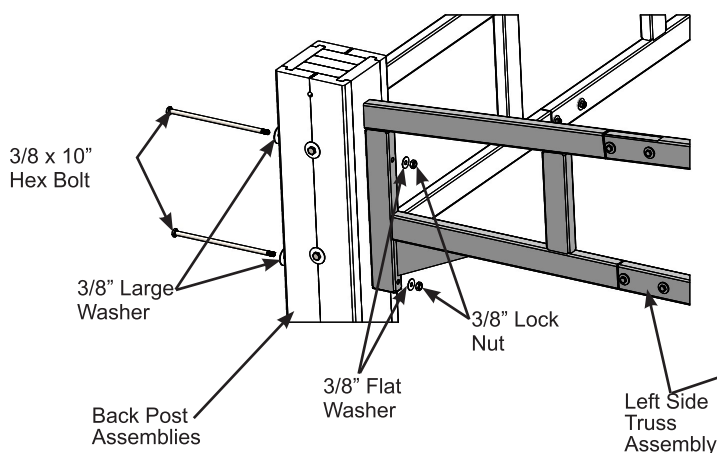

F12.3

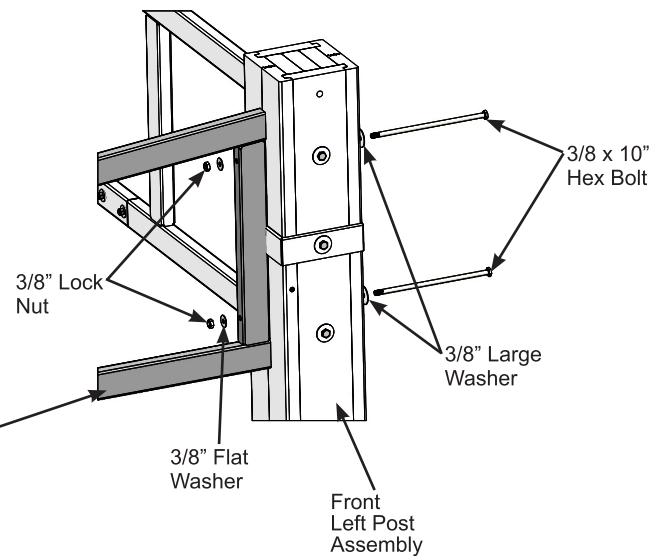

Hardware

8 x 3/8 x 10" Hex Bolt
(3/8" large washer, 3/8" flat washer and 3/8" lock nut)

Step 12: Frame Assembly

Part 2



D: Through the hole in the Post Joint Cover, pre-drill with a 1/8" drill bit then attach with one 5/16 x 3", 1/4" Shank Hex Lag (with 1/4-5/16 large washer) per Post Joint Cover. (F12.4 and F12.5)

F12.4

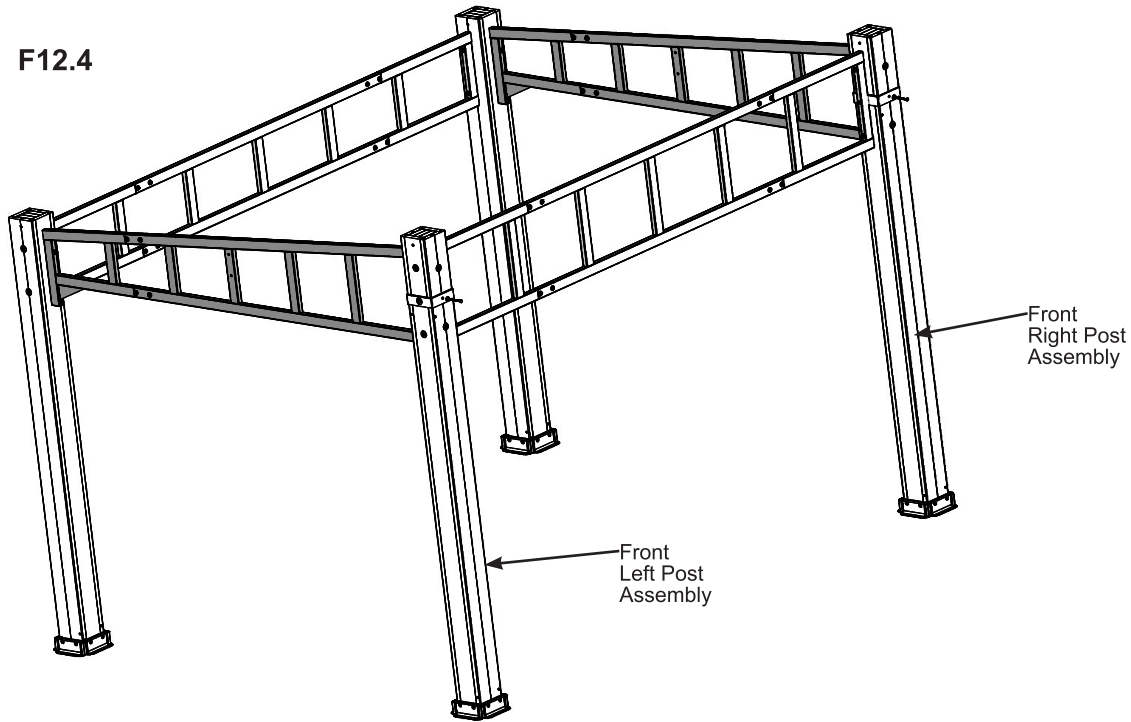

F12.5

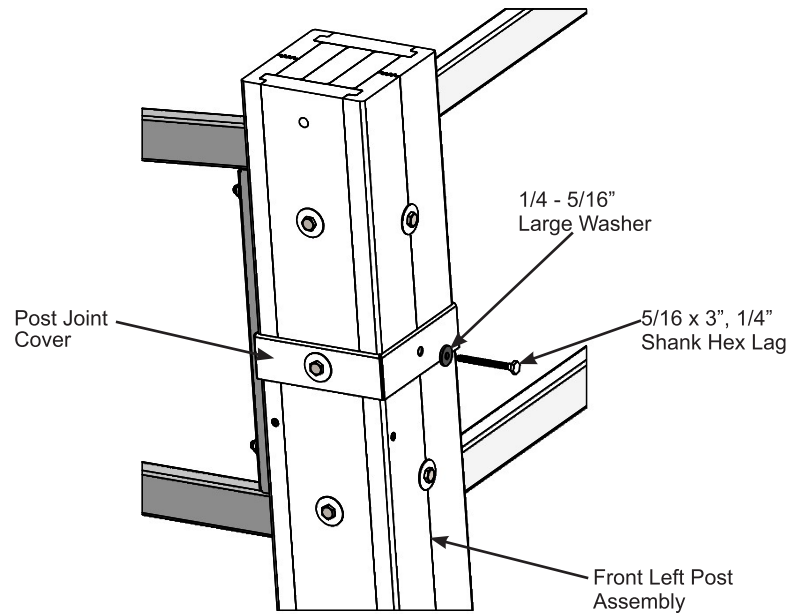

Hardware

2 x 5/16 x 3", 1/4" Shank Hex Lag
(1/4 - 5/16" large washer)

Step 12: Frame Assembly

Part 3

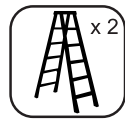

E: With the holes on top of the Mid Truss Assembly install the Mid Truss Assembly between the Side Truss Assemblies with four 5/16 x 4-1/4" Hex Bolts (with two 5/16" flat washer, 1/8" thick and 5/16" lock nut). (F12.6 and F12.7)

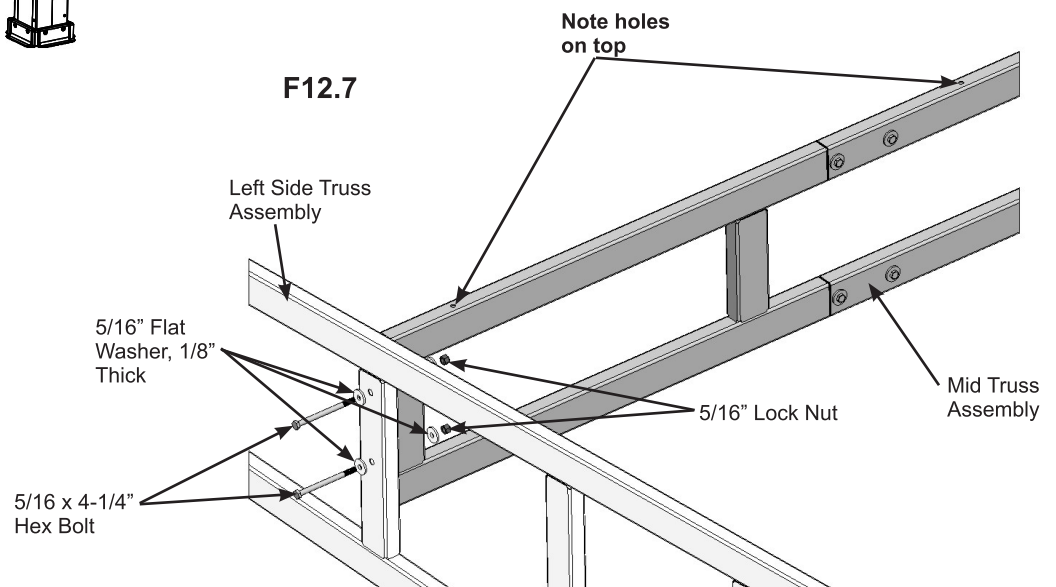
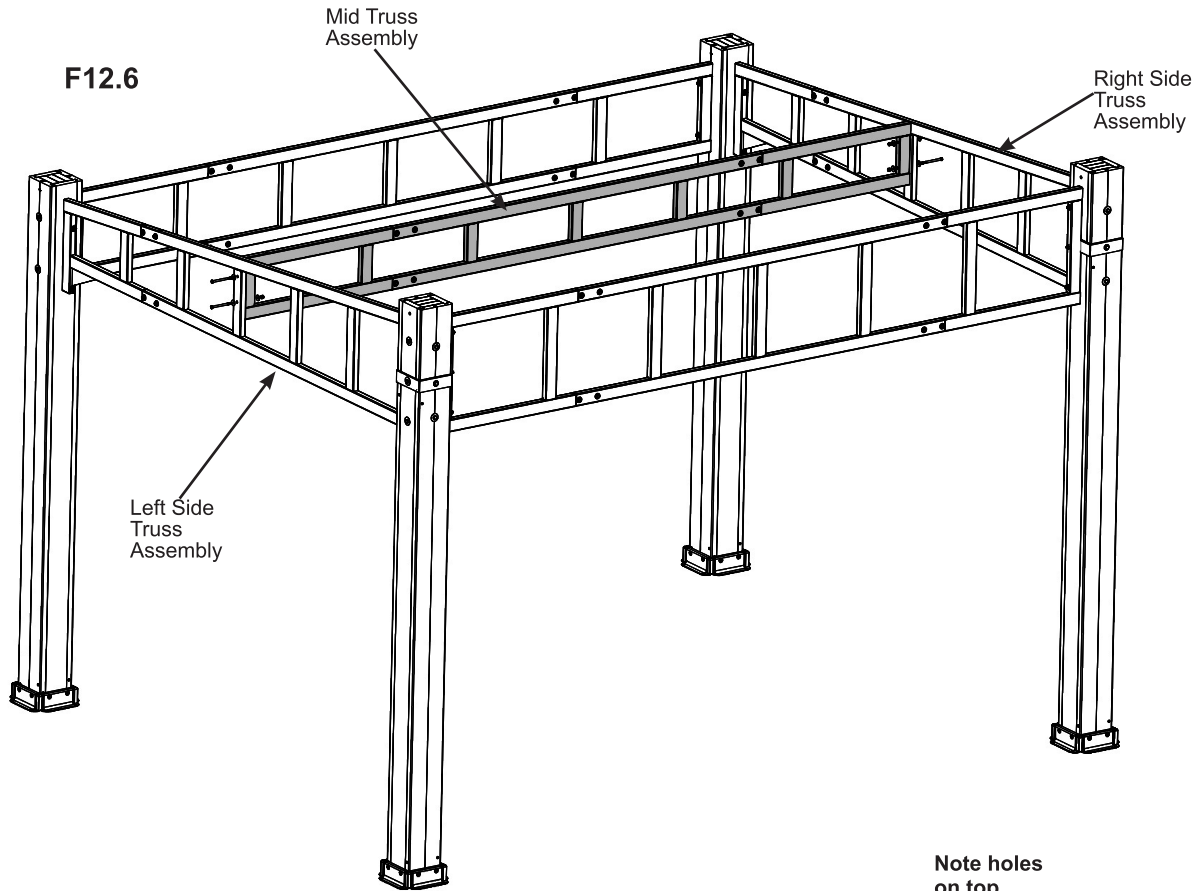

Hardware

4 x 5/16 x 4-1/4" Hex Bolt
(5/16" flat washer, 1/8" thick x 2, 5/16" lock nut)

Step 13: Check Frame Dimensions

A: The diagonal distance between the inside of two posts should be 14' 10-7/8" (4.544 m) (measuring from posts not Post Mounts). (F13.1)

F13.1

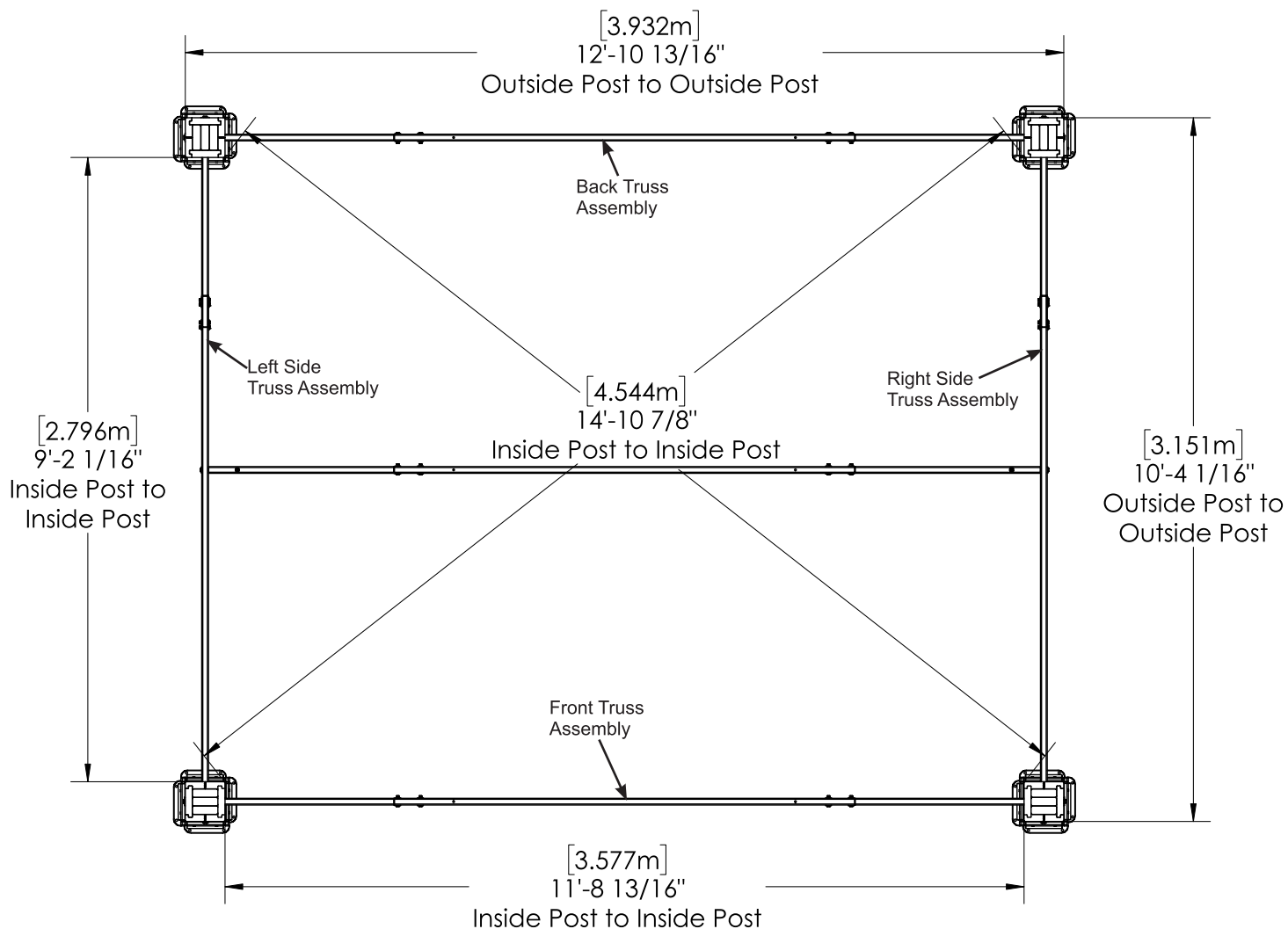

Step 14: Left Roof Panel Assembly Part 1

A: Lie out the rafters on a flat surface with the grooves facing up as shown in F14.1.

B: Tightly connect Rafter Long and Rafter Shorts using two 5/16 x 1-1/4" Hex Bolts (with 5/16" lock washer, 1/4- 5/16" large washer and 5/16" t-nut) per rafter assembly. (F14.1 and F14.2)

Note the direction of the hex bolts in each assembly.

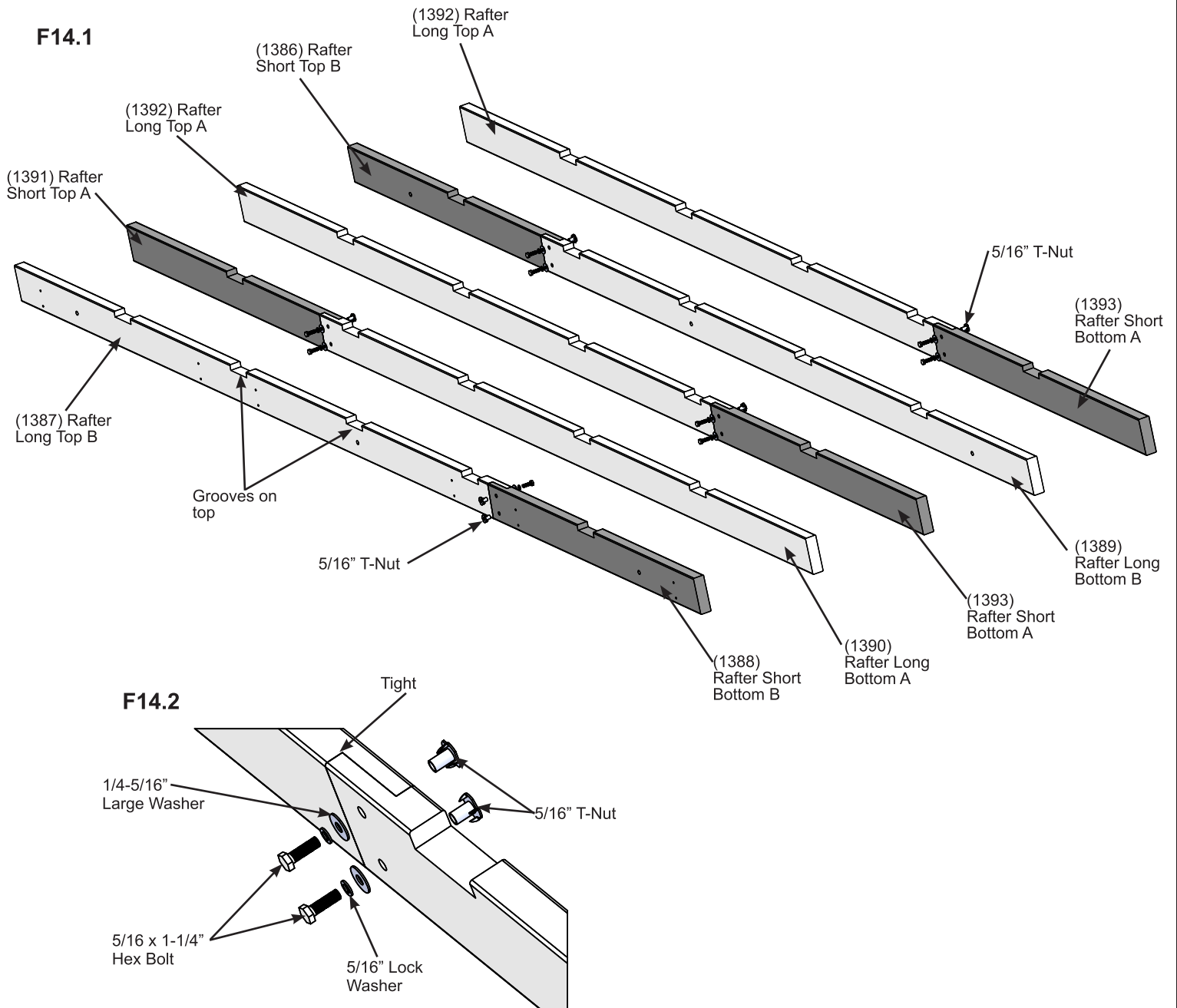

Wood Parts

- | | |
|----------------------------------|----------------------------------|
| 1 x (1386) Rafter Short Top B | 1 x (1390) Rafter Long Bottom A |
| 1 x (1387) Rafter Long Top B | 1 x (1391) Rafter Short Top A |
| 1 x (1388) Rafter Short Bottom B | 2 x (1392) Rafter Long Top A |
| 1 x (1389) Rafter Long Bottom B | 2 x (1393) Rafter Short Bottom A |

Hardware

- 10 x 5/16 x 1-1/4" Hex Bolt
 (5/16" lock washer, 1/4-5/16" large washer, 5/16" t-nut)

Step 14: Left Roof Panel Assembly Part 2

C: On each end of the Rafter Assemblies place one (1384) Fascia so that the top is level with the Rafter Assemblies and the outside edges are flush. (F14.3, F14.4 and F14.5)

D: Attach (1384) Fascia to Rafter Assemblies with 10 #8 x 2-1/2" Wood Screws per Fascia. (F14.3 and F14.4)

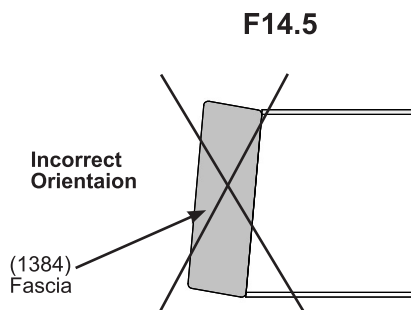
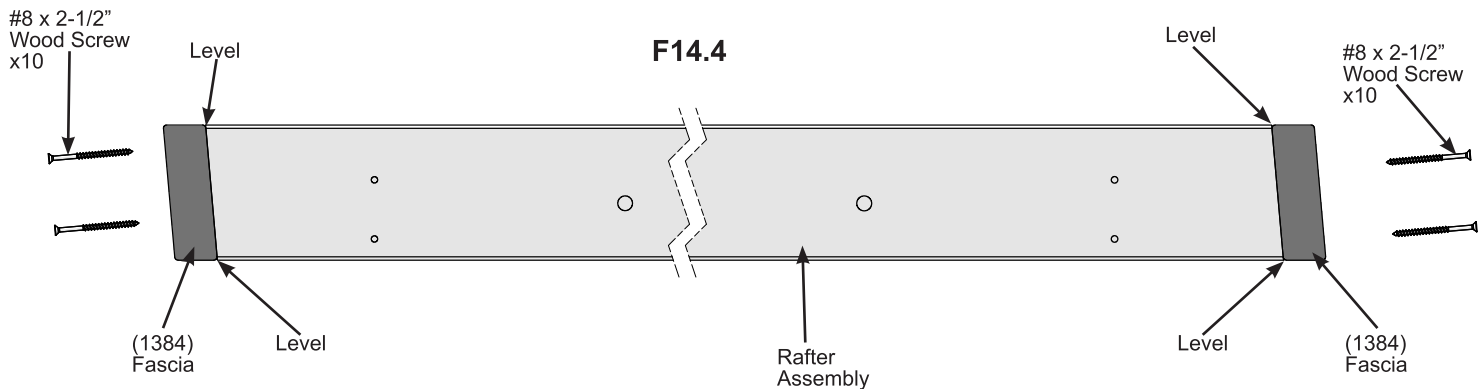
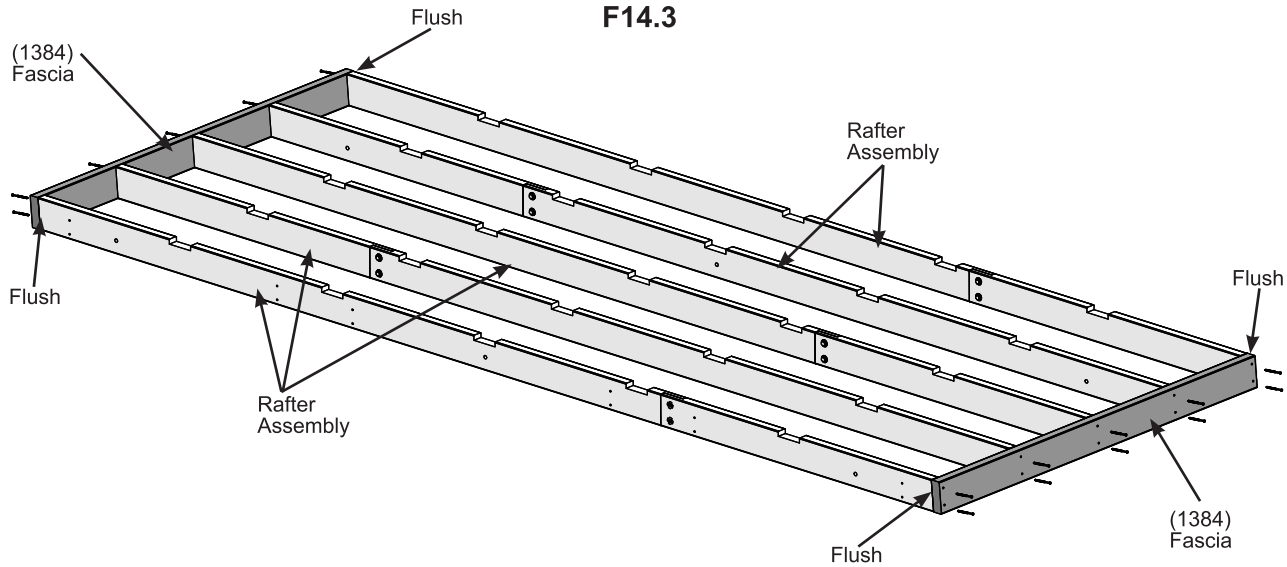

Wood Parts

2 x (1384) Fascia

Hardware

20 x #8 x 2-1/2" Wood Screw

Step 14: Left Roof Panel Assembly Part 3

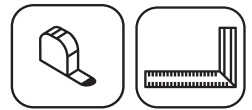

E: Place five (1385) Straps in the notches of each rafter assembly so the ends are flush to the outside edges of the outside rafter assemblies. (F14.7)

F: Make sure the Rafter Assembly is square. The diagonal distance between the corners of the Fascia's is 155-1/8" [3.940m]. Attach (1385) Straps to Rafter Assemblies with 10 #8 x 1-1/2" Wood Screws per strap. (F14.6, F14.7 and F14.8)

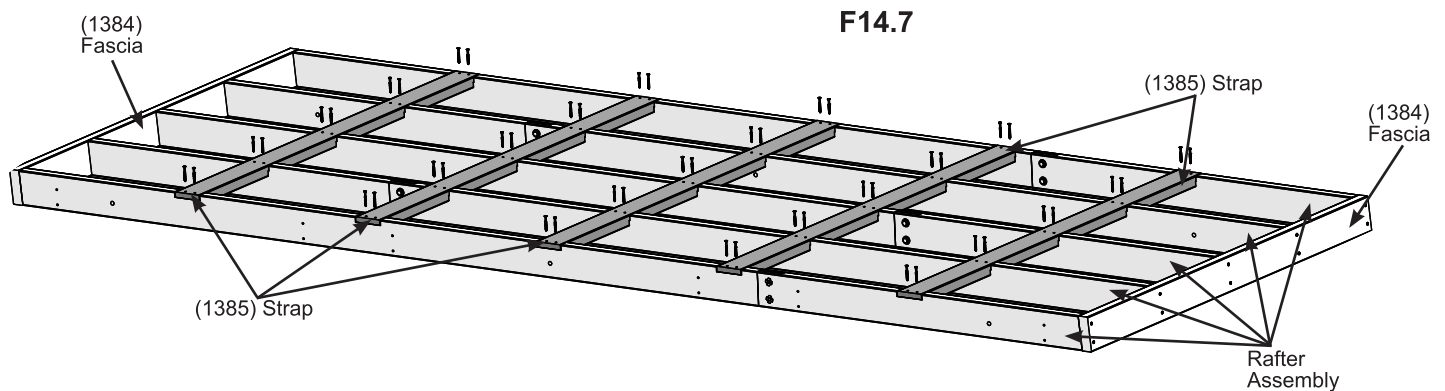
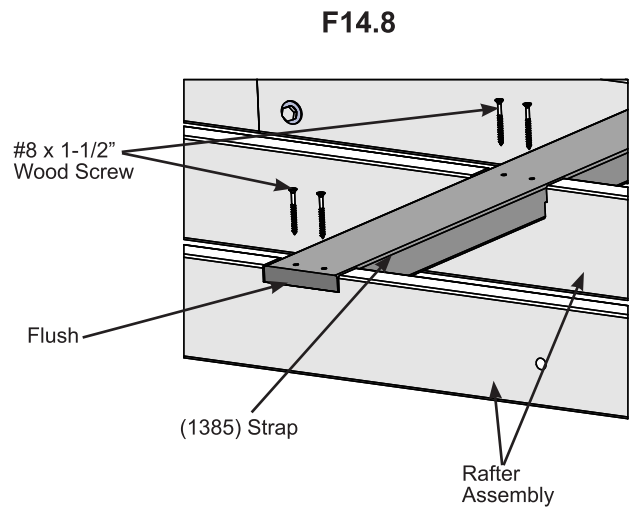
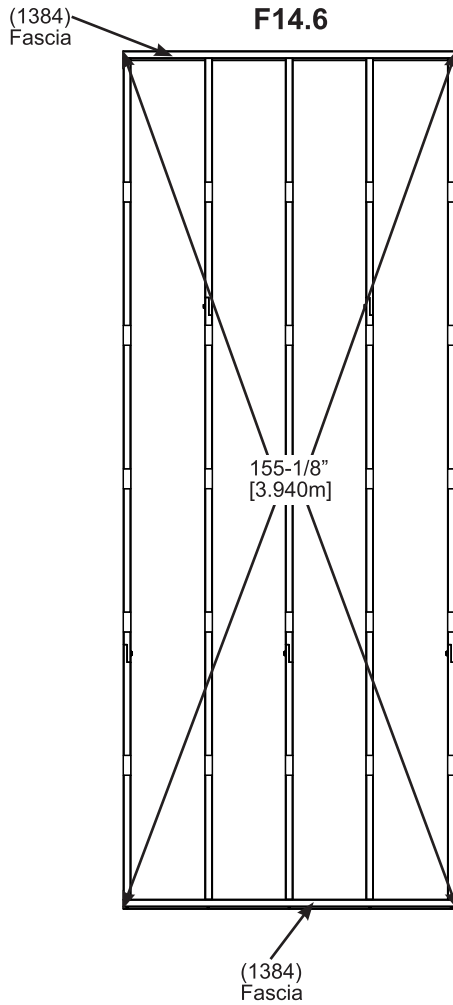

Wood Parts

5 x (1385) Strap

Hardware

50 x #8 x 1-1/2" Wood Screw

Step 14: Left Roof Panel Assembly Part 4

G: On the left side of (1389) Rafter Long Bottom B under the middle (1385) Strap attach one Truss Bracket using one 5/16 x 1-1/2" Hex Bolt (with 5/16" lock washer, 5/16" flat washer and 5/16" t-nut). (F14.9 and F14.10)

F14.9

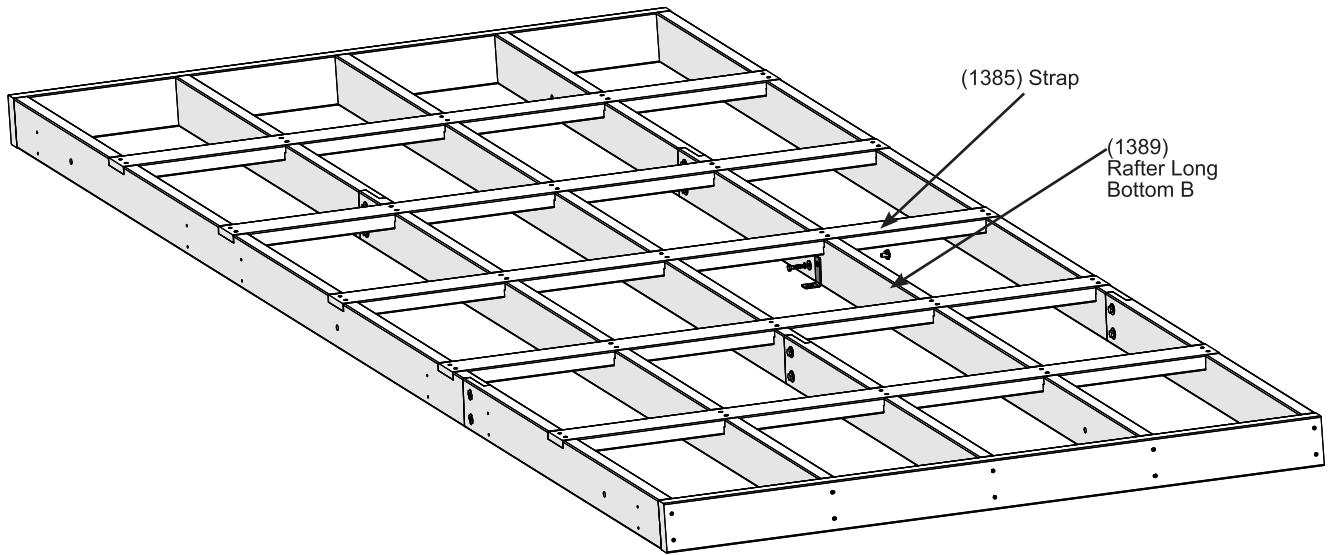

F14.10

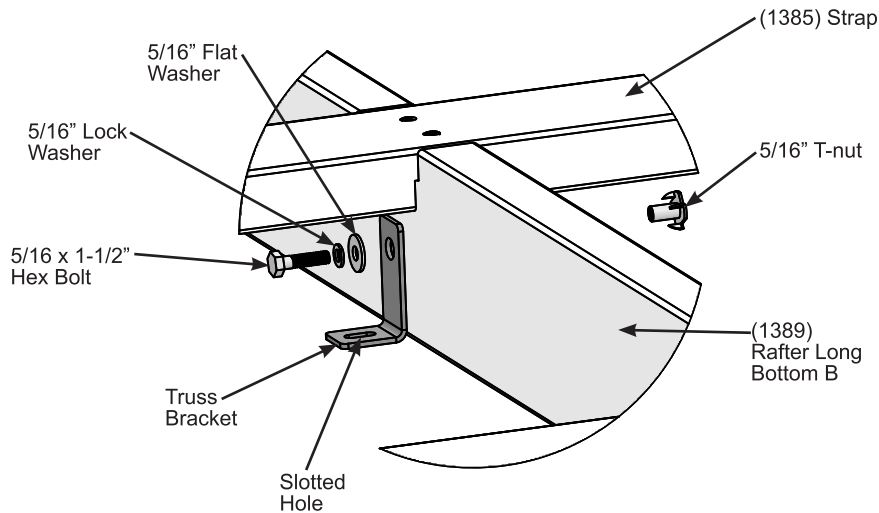

Components

1 x Truss Bracket

Hardware

1 x 5/16 x 1-1/2" Hex Bolt
(5/16" lock washer, 5/16" flat washer and 5/16" t-nut)

Step 14: Left Roof Panel Assembly Part 5



H: Flip Roof Panel over and install three (1394) Roof Eave Supports centered on the middle three (1385) Straps between (1389) Rafter Long Bottom B and (1392) Rafter Long Top A with two #8 x 3-1/2" Wood Screws per Support. (F14.11, F14.12 and F14.13)

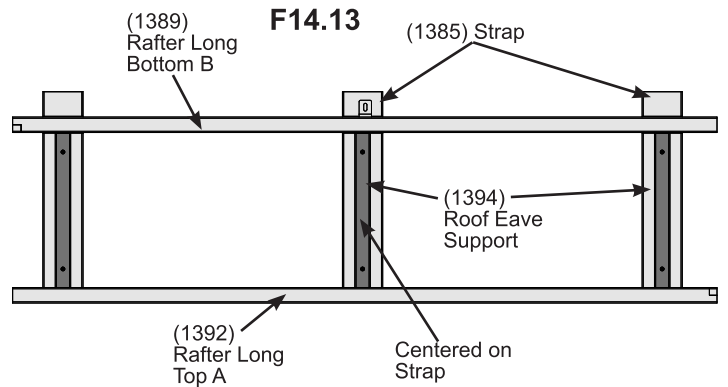
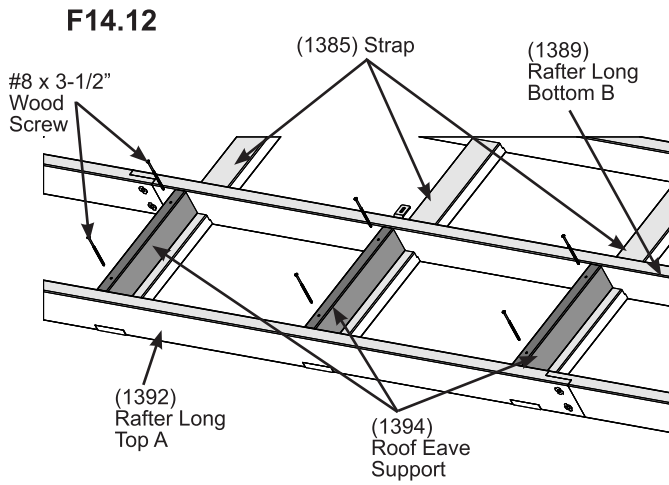
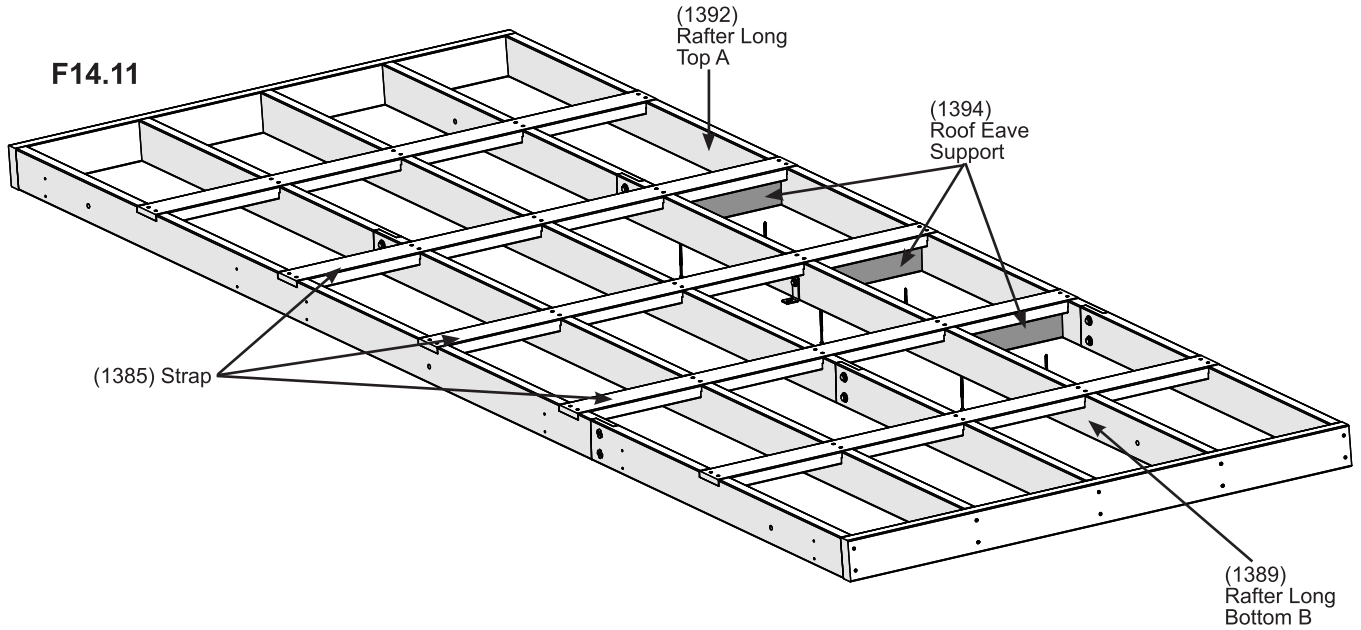

Wood Parts

3 x (1394) Roof Eave Support

Hardware

6 x #8 x 3-1/2" Wood Screw

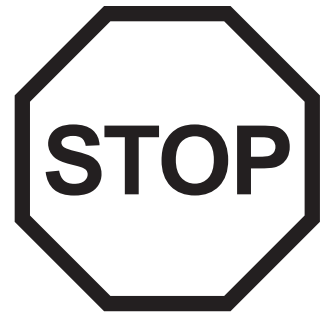
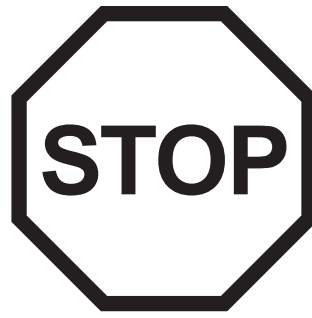

INSTALLING ROOFING MATERIAL

CAUTION!

Roofing material may have sharp edges! Wear gloves!

HANDLE WITH CARE!

Place roofing material on a non-abrasive surface before assembly as it can bend, dent and scratch easily.

**WARNING – DO NOT OVER TIGHTEN ROOFING SCREWS!
Over tightening screws will cause roofing material to crush.**

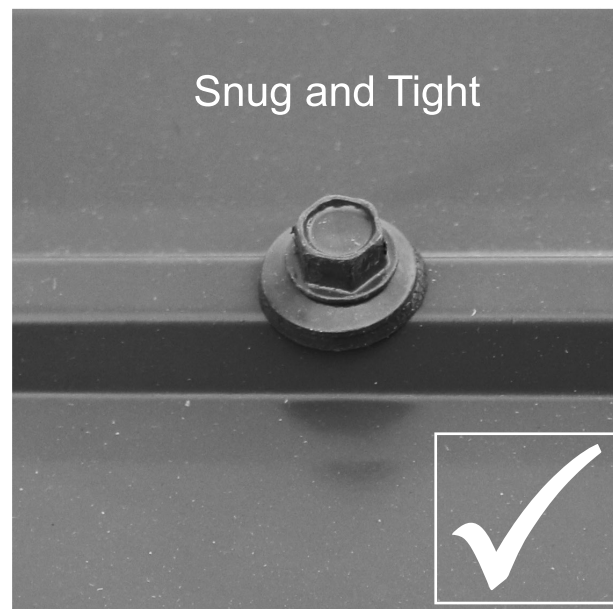

The roofing screws can easily crush the Roof Panels and Roof Edges when using a power drill. We recommend hand tightening the roofing screws so that they sit snug and tight to the roofing material.

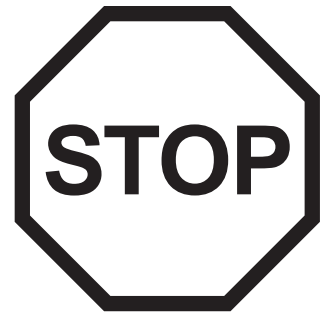
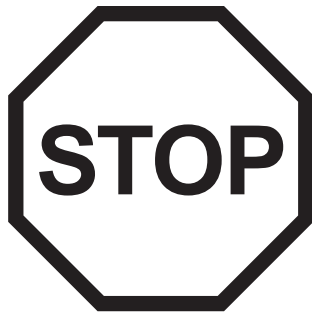

INSTALLING ROOFING MATERIAL

CAUTION!

Roofing material may have sharp edges! Wear gloves!

BE SURE TO REMOVE ALL PLASTIC COVERING, ON BOTH SIDES OF THE ALUMINUM PANELS AND TRIM, DIRECTLY BEFORE INSTALLING EACH PIECE. *(One side is clear and the other is blue, both must be removed.)*

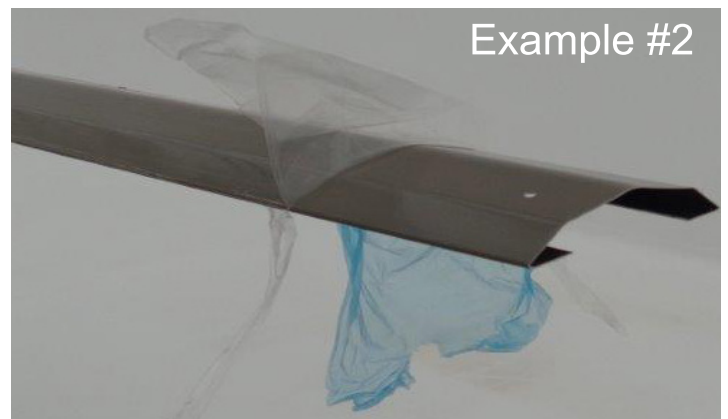
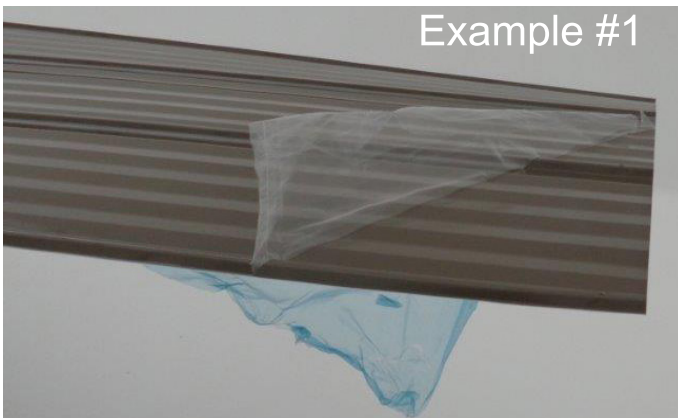

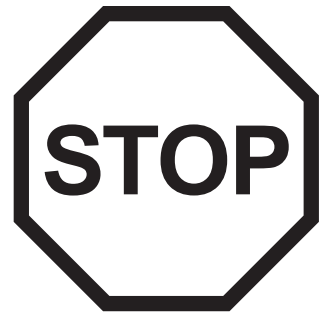
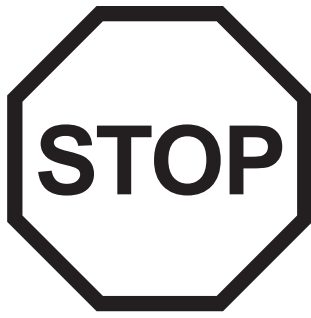

ROOFING PANEL IDENTIFICATION

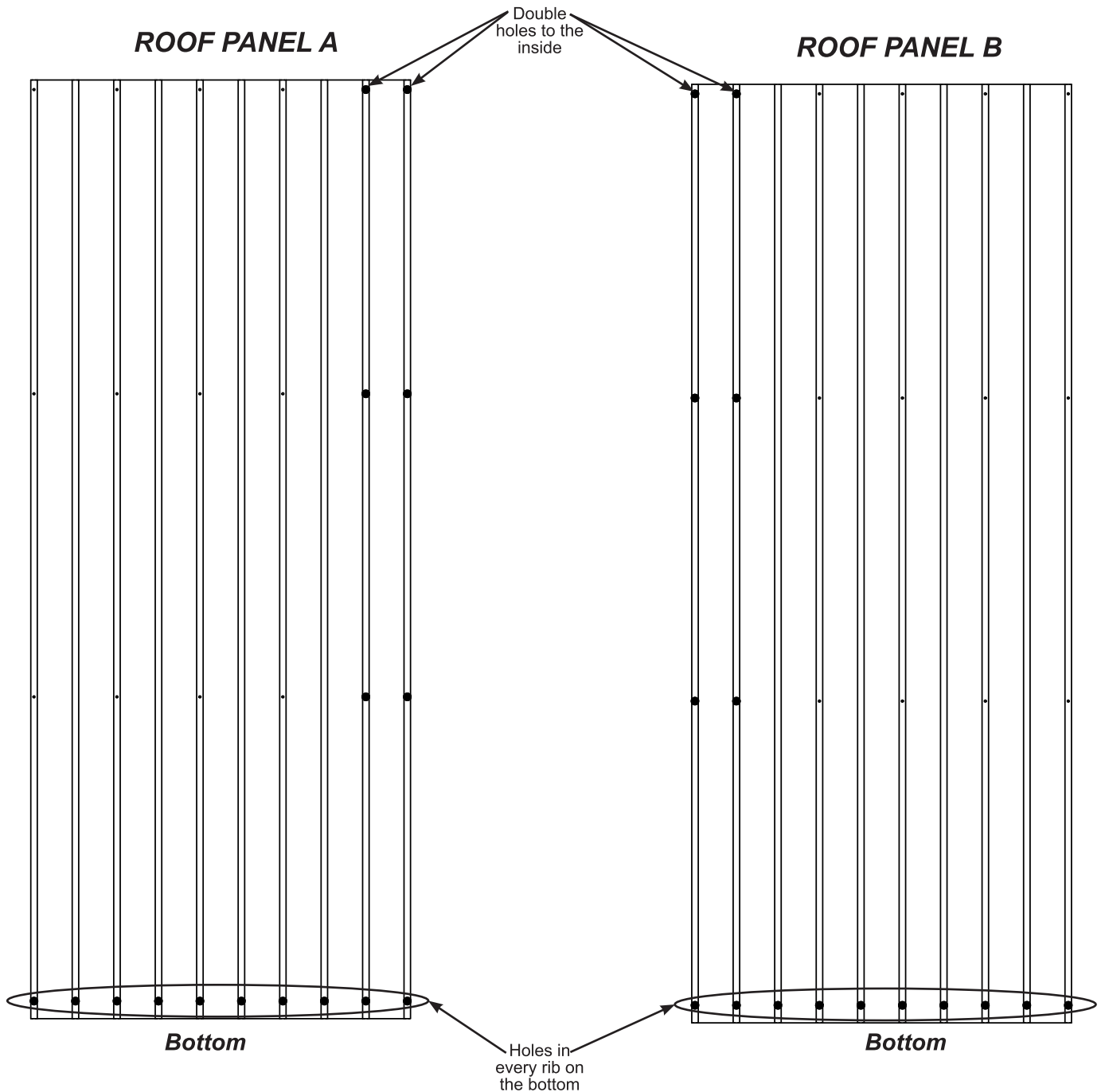

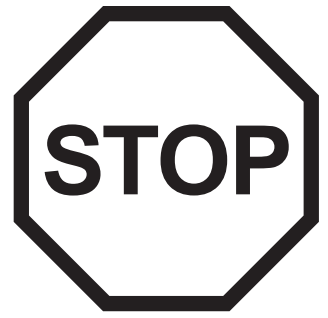
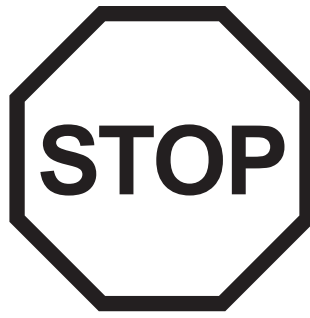
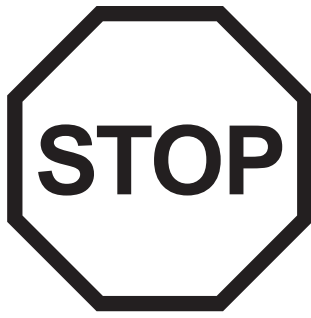
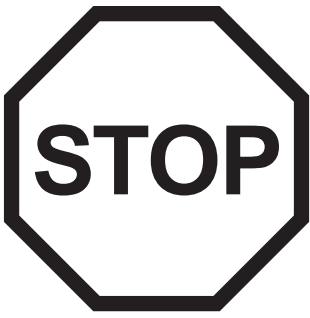

INSTALLING ROOFING PANELS

- Make sure wood panels are square
- Make sure angles on wood panels are correct for top and bottom
- Layout panels first in correct orientation and with a 1" overhang at bottom before applying silicone

Repeat this process for Left, Middle and Right Roof Panel assemblies.

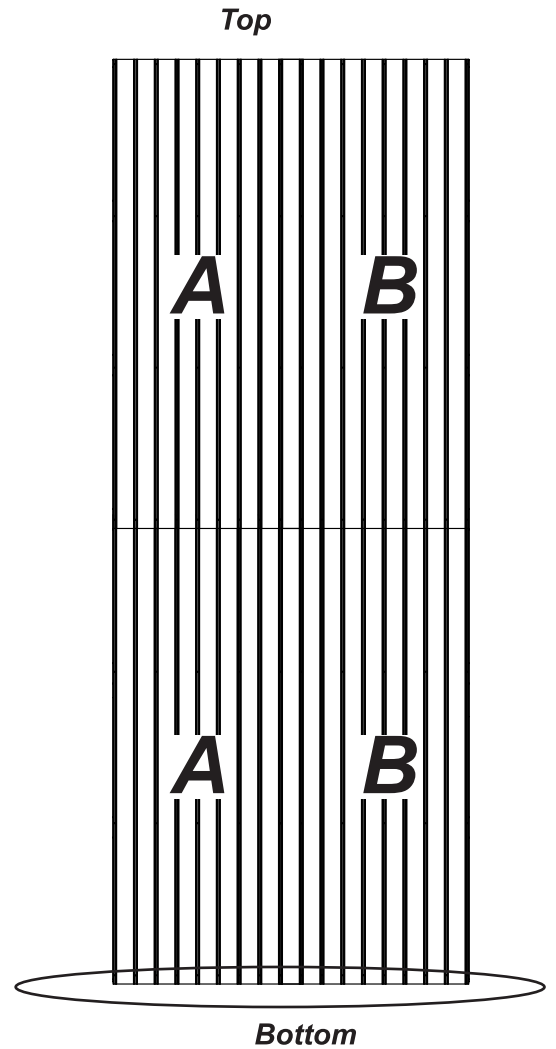
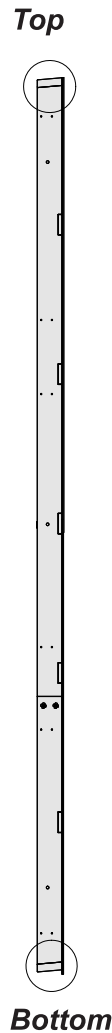
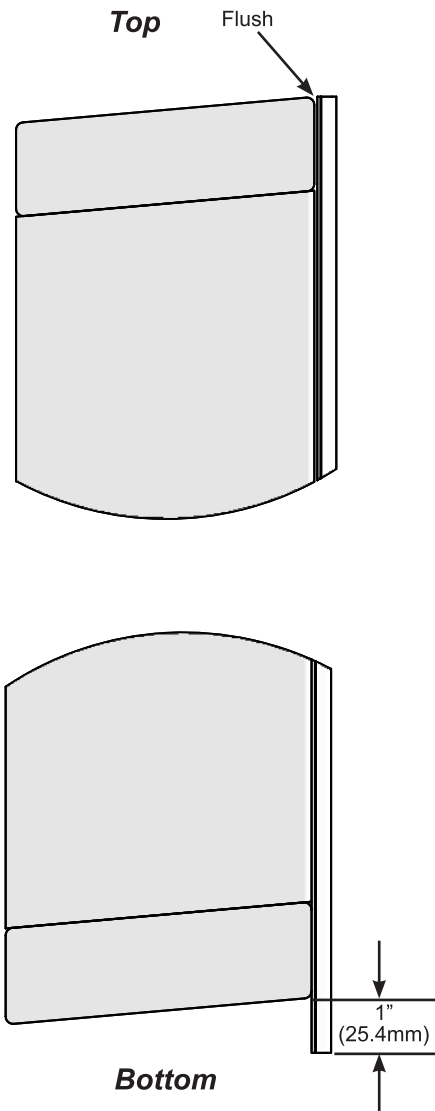

Step 15: Attach Roof Panels - Left Roof Panel Part 1



A: Place one Flat Roof Panel B on top of Left Roof Panel Assembly so the end with the holes in each rib are at the bottom. (F15.1, F15.2 and F15.3) The Roof Panel should overhang 1" (25.4 mm) along the bottom. Refer to page 36 for Roof Panel Identification

B: On the left side of Flat Roof Panel B between the first two ribs apply a small, evenly distributed bead of sealant over the perimeter of the flat surface. (F15.4)

F15.1

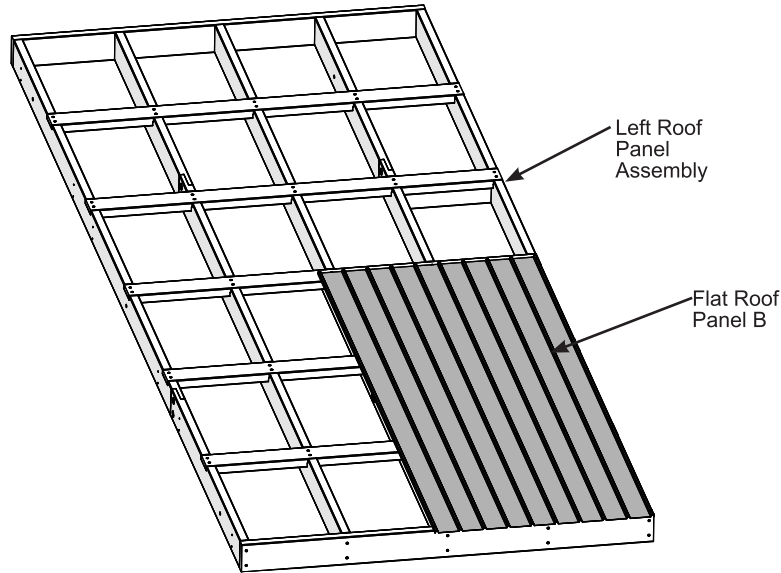

F15.2

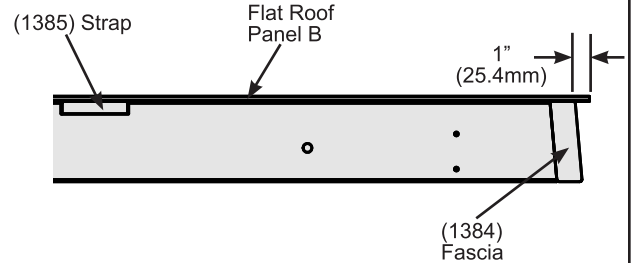

F15.3

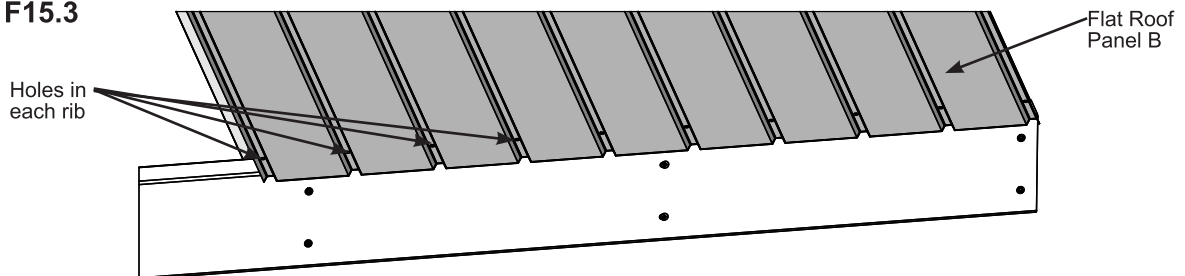

Note: All surfaces to be clean, dry, dust and grease free before application with temperatures above 5°C (41°F), no warmer than 35°C (95°F).

- Apply sealant in small beads and smooth as required.
- Clean excess with a cloth or paper towel before it skins over.
- Always wear safety glasses and rubber gloves when using product.

See page 6 for Warning and First Aid Information.

F15.4

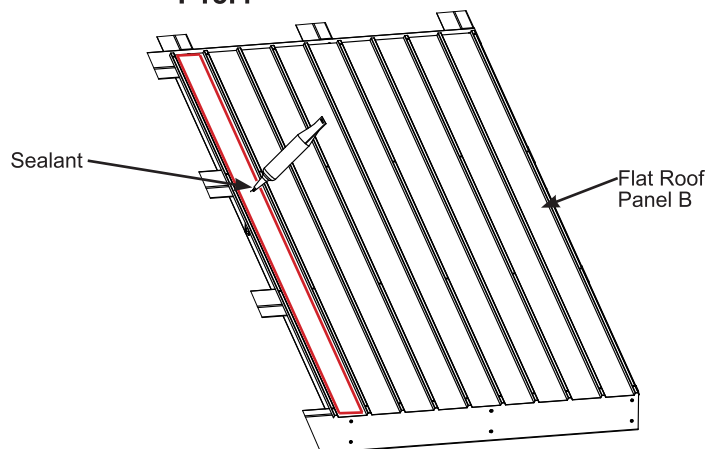

Roof Parts

1 x Flat Roof Panel B
Sealant Tube

Step 15: Attach Roof Panels - Left Roof Panel Part 2



C: With the holes in every rib on the bottom place one Flat Roof Panel A so it overlaps Flat Roof Panel B by two ribs and the holes are aligned. (F15.5 and F15.6)

Refer to page 36 for Roof Panel Identification

D: Across the top of Flat Roof Panel A and Flat Roof Panel B apply two small, evenly distributed beads of sealant 1-1/2" apart. (F15.7)

F15.5

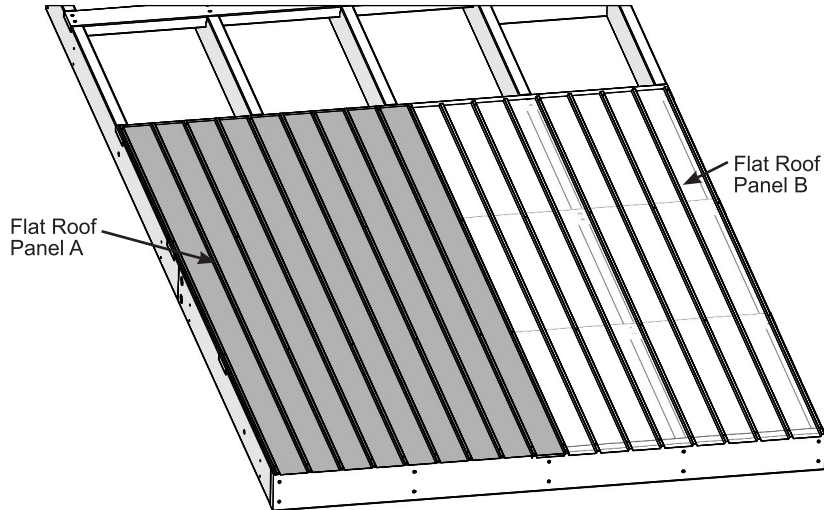

F15.6

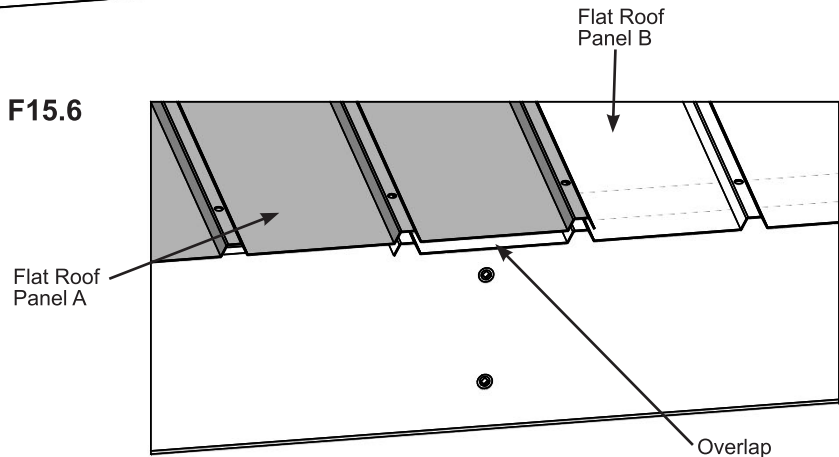

Note: All surfaces to be clean, dry, dust and grease free before application with temperatures above 5°C (41°F), no warmer than 35°C (95°F).

- Apply sealant in small beads and smooth as required.
- Clean excess with a cloth or paper towel before it skins over.
- Always wear safety glasses and rubber gloves when using product.

See page 6 for Warning and First Aid Information.

F15.7

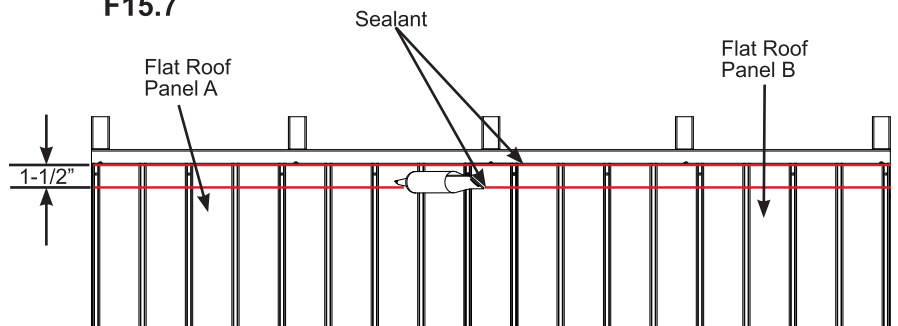

Roof Parts

1 x Flat Roof Panel A

Step 15: Attach Roof Panels - Left Roof Panel Part 3

E: With the holes in every rib on the bottom place one Flat Roof Panel B on top of Left Roof Panel Assembly so the holes align with the top holes in the previously installed Flat Roof Panel B. (F15.8)

Refer to page 36 for Roof Panel Identification

F: On the left side of Flat Roof Panel B between the first two ribs apply a small, evenly distributed bead of sealant over the perimeter of the flat surface. (F15.9)

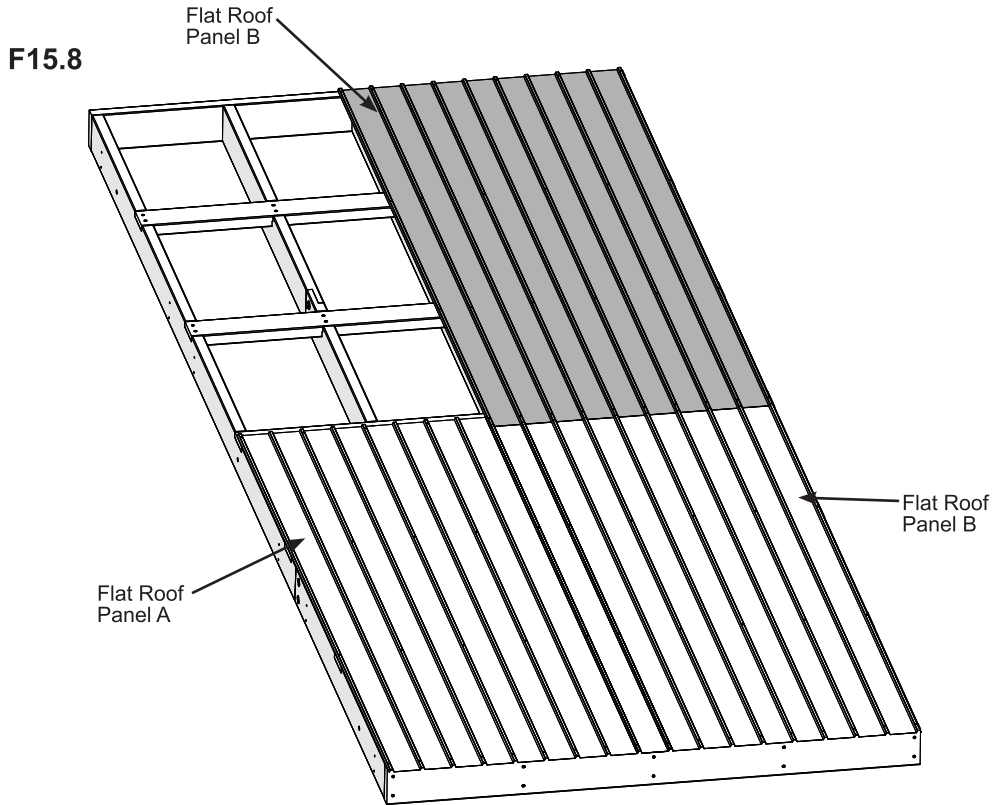

Note: All surfaces to be clean, dry, dust and grease free before application with temperatures above 5°C (41°F), no warmer than 35°C (95°F).

- Apply sealant in small beads and smooth as required.
- Clean excess with a cloth or paper towel before it skins over.
- Always wear safety glasses and rubber gloves when using product.

See page 6 for Warning and First Aid Information.

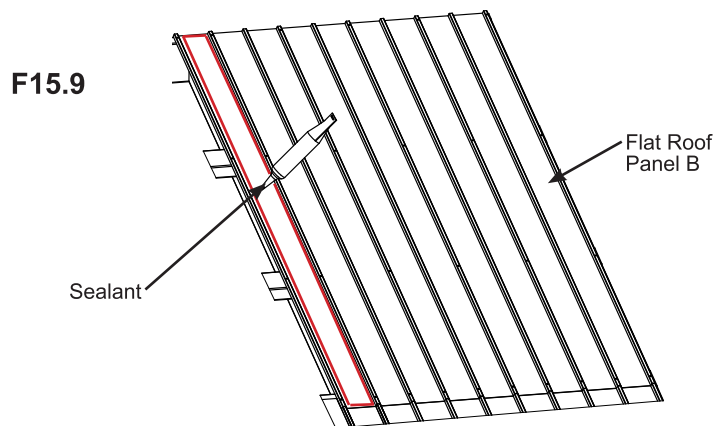

Roof Parts

1 x Flat Roof Panel B

Step 15: Attach Roof Panels - Left Roof Panel Part 4

G: With the holes in every rib on the bottom place one Flat Roof Panel A so it overlaps Flat Roof Panel B by two ribs and the holes are aligned. (F15.10)

Refer to page 36 for Roof Panel Identification

H: Adjust the Roofing Panels so they are flush to the top and left side of the Panel Assembly. (F15.10)

I: Attach with 62 #8 x 1" Roofing Screws in the locations shown in F15.10. Be sure not to over tighten screws.

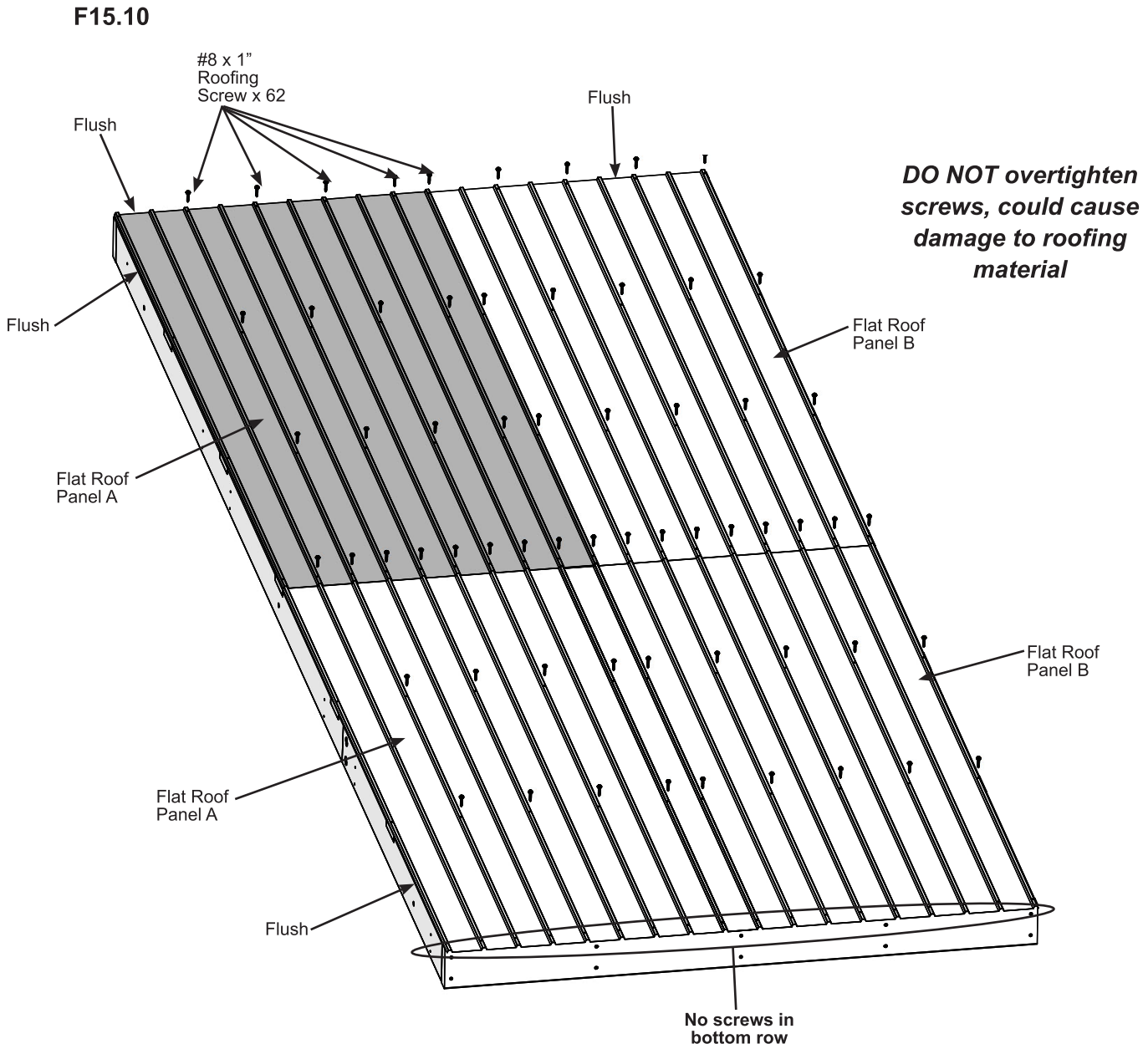

Roof Parts

1 x Flat Roof Panel A

Hardware

62 x #8 x 1" Roofing Screw

Step 15: Attach Roof Panels - Left Roof Panel Part 5

J: Apply sealant to the inside groove of the Flat Roof Clip - Short and Flat Roof Clip Long. (F15.11)

K: Place one Flat Roof Clip - Short on the outside rib of Flat Roof Panel A with the flange facing inward. Ensure holes are aligned and install with three #8 x 1" Roofing Screws. (F15.12 and F15.13)

L: Place one Flat Roof Clip - Long on the outside rib of Flat Roof Panel A with holes aligned and tight to Flat Roof Clip - Short. Attach with nine #8 x 1" Roofing Screws. (F15.12 and F15.14)

NOTE: Only every other hole lines up with the holes in the Roof Panels.

DO NOT overtighten screws, could cause damage to roofing material

F15.12

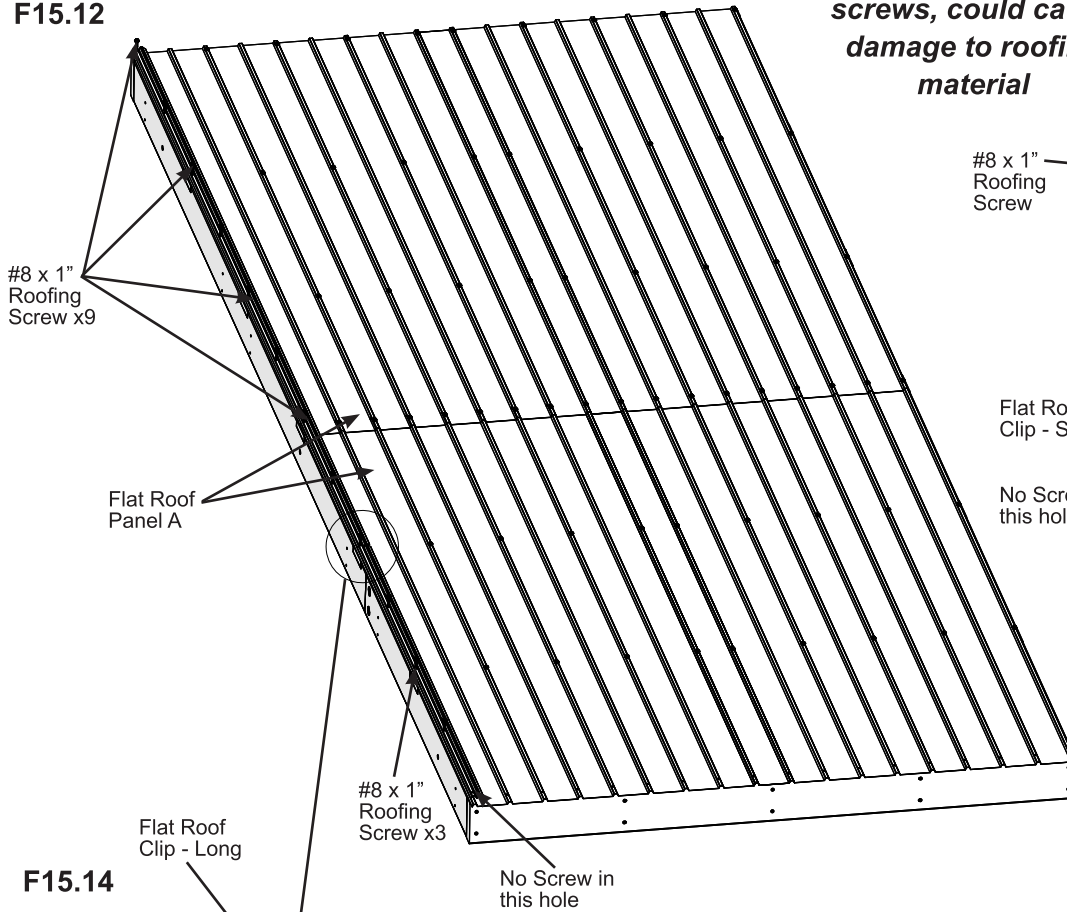

F15.13

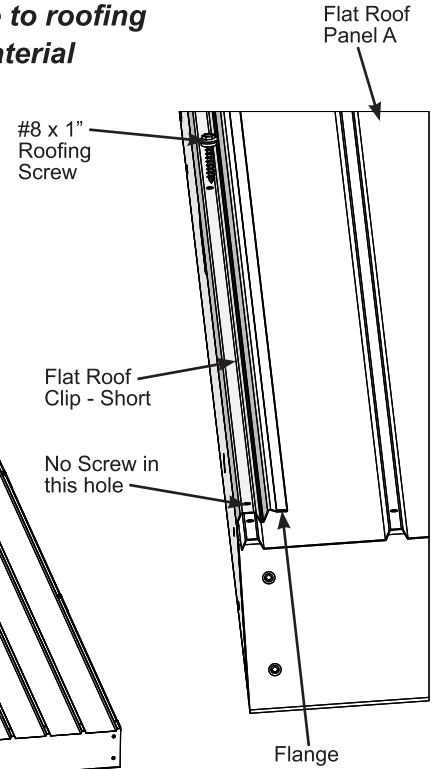

F15.14

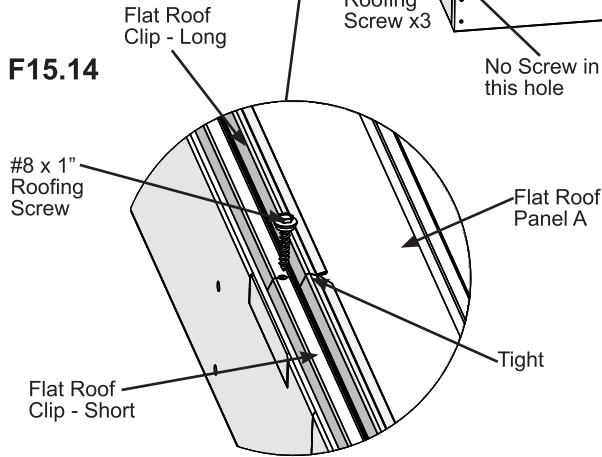

F15.11

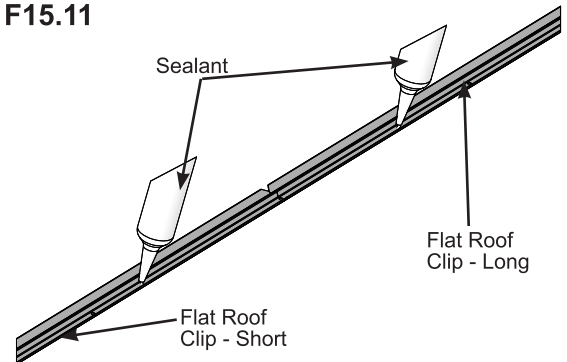

Roof Parts

- 1 x Flat Roof Clip - Short
- 1 x Flat Roof Clip - Long

Hardware

- 12 x #8 x 1" Roofing Screw

Step 16: Mid Roof Panel Assembly Part 1

A: Lie out the rafters on a flat surface with the grooves facing up as shown in F16.1.

B: Tightly connect Rafter Long and Rafter Shorts using two 5/16 x 1-1/4" Hex Bolts (with 5/16" lock washer, 1/4- 5/16" large washer and 5/16" t-nut) per rafter assembly. (F16.1 and F16.2)

Note the direction of the hex bolts in each assembly.

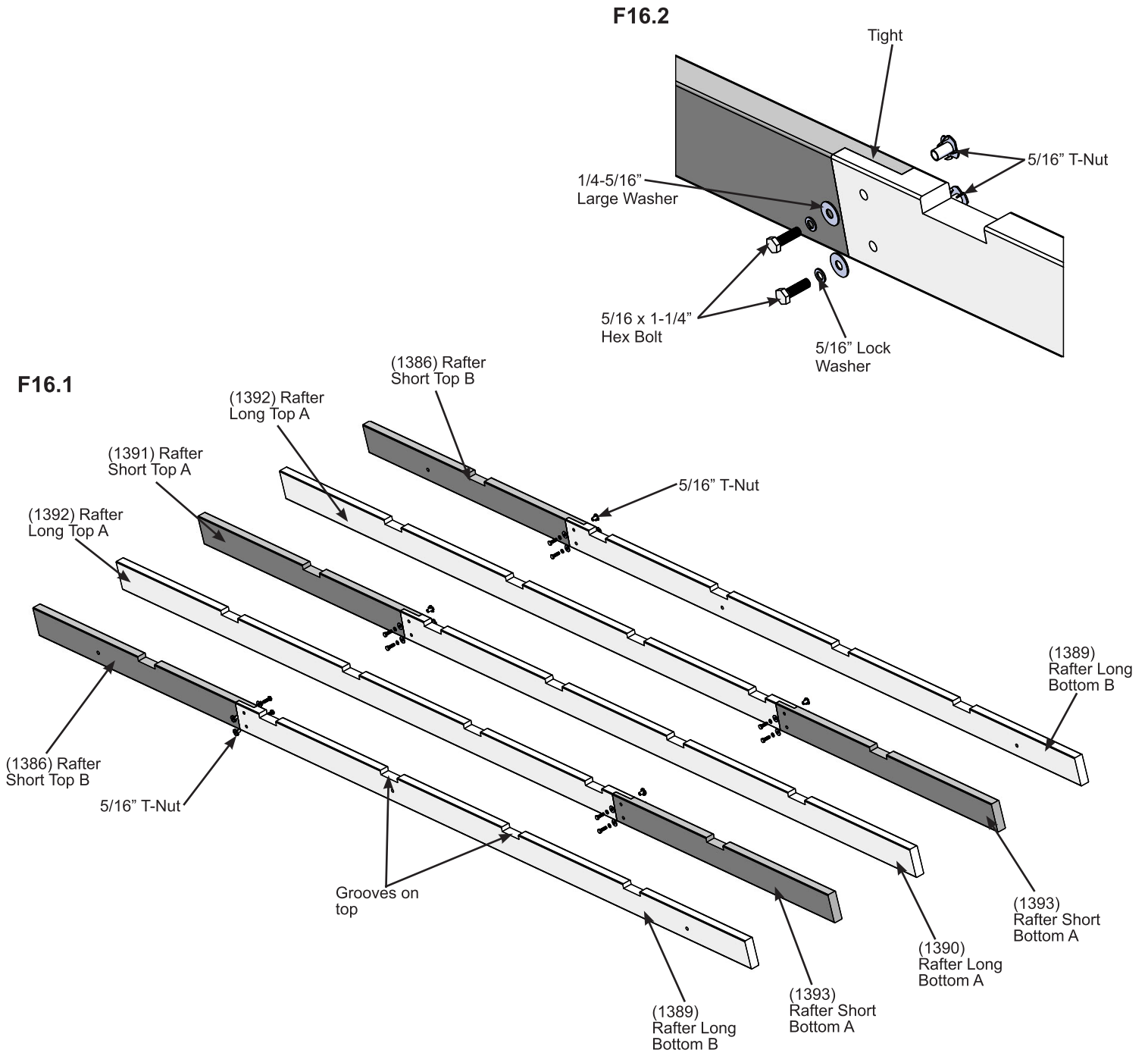

Wood Parts

- | | |
|---------------------------------|----------------------------------|
| 2 x (1386) Rafter Short Top B | 1 x (1391) Rafter Short Top A |
| 2 x (1389) Rafter Long Bottom B | 2 x (1392) Rafter Long Top A |
| 1 x (1390) Rafter Long Bottom A | 2 x (1393) Rafter Short Bottom A |

Hardware

- 10 x 5/16 x 1-1/4" Hex Bolt
 (5/16" lock washer, 1/4-5/16" large washer, 5/16" t-nut)

Step 16: Mid Roof Panel Assembly Part 2

C: On each end of the Rafter Assemblies place one (1384) Fascia so that the top is level with the Rafter Assemblies and the outside edges are flush. (F16.3, F16.4 and F16.5)

D: Attach (1384) Fascia to Rafter Assemblies with 10 #8 x 2-1/2" Wood Screws per Fascia. (F16.3 and F16.4)

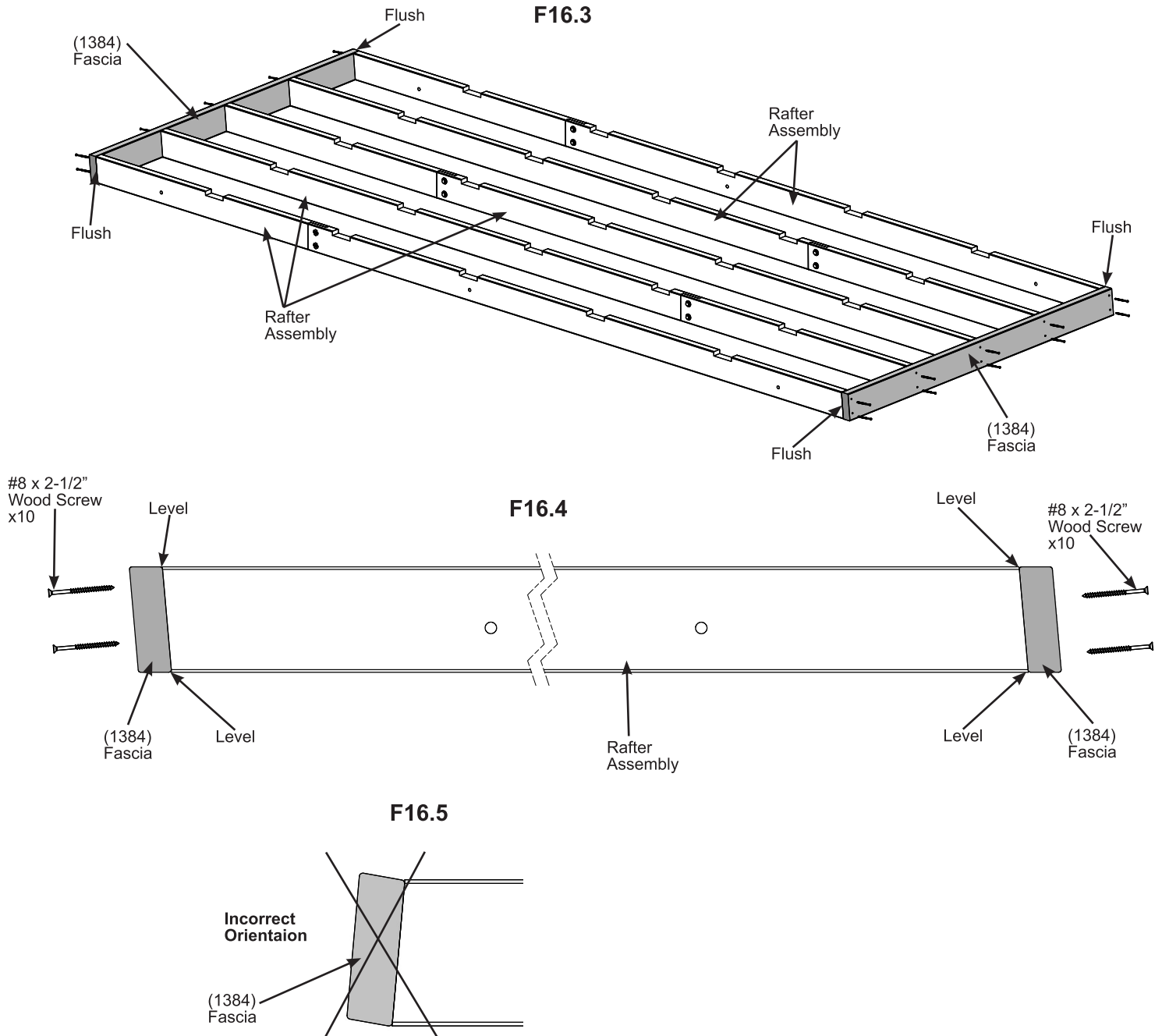

Wood Parts

2 x (1384) Fascia

Hardware

20 x #8 x 2-1/2" Wood Screw

Step 16: Mid Roof Panel Assembly Part 3



E: Place five (1385) Straps in the notches of each rafter assembly so the ends are flush to the outside edges of the outside rafter assemblies. (F16.7)

F: Make sure the Rafter Assembly is square. The diagonal distance between the corners of the Fascia's is 155-1/8" [3.940m]. Attach (1385) Straps to Rafter Assemblies with 10 #8 x 1-1/2" Wood Screws per strap. (F16.6, F16.7 and F16.8)

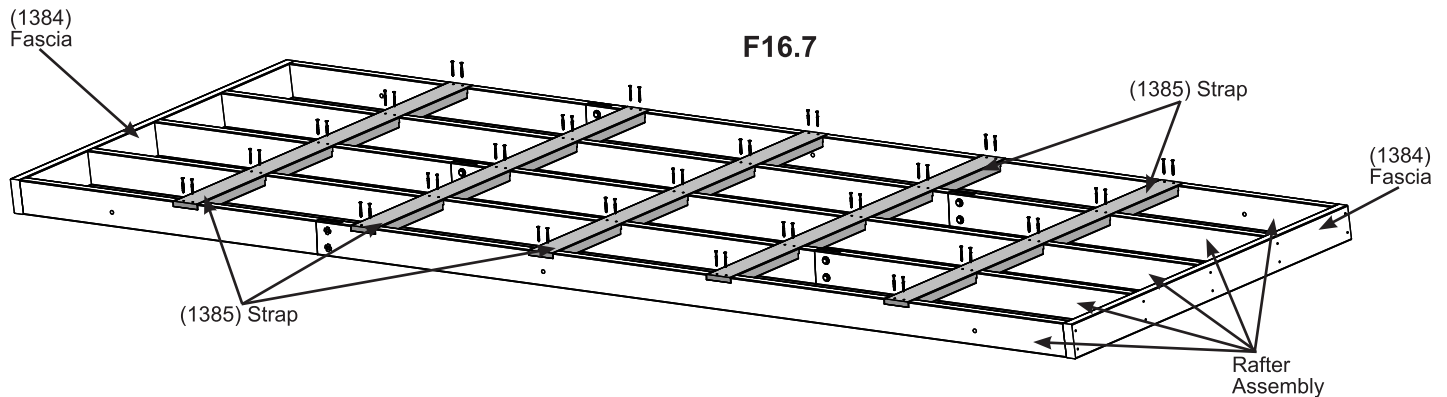
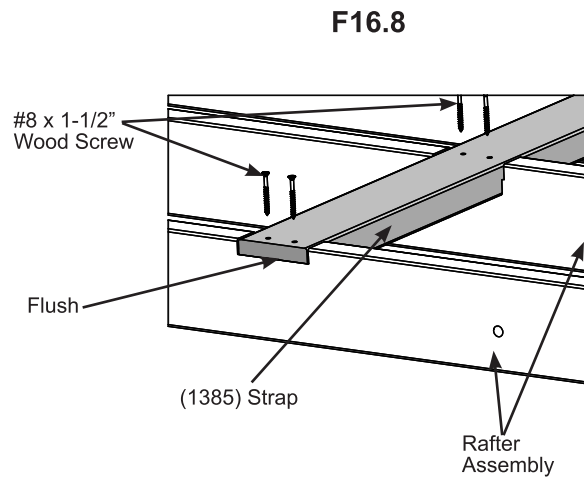
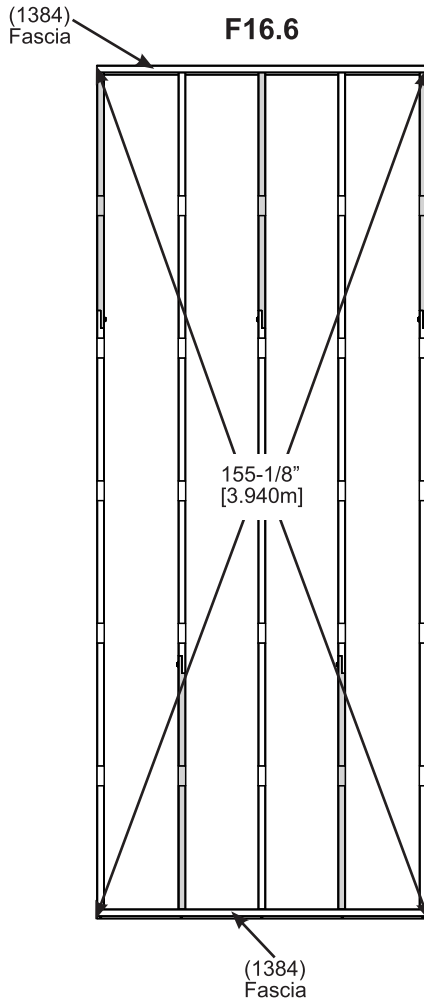

Wood Parts

5 x (1385) Strap

Hardware

50 x #8 x 1-1/2" Wood Screw

Step 17: Attach Roof Panels - Mid Roof Panel Part 1



A: Place one Flat Roof Panel B on top of Mid Roof Panel Assembly so the end with the holes in each rib are at the bottom. (F17.1, F17.2 and F17.3) The Roof Panel should overhang 1" (25.4mm) along the bottom. Refer to page 36 for Roof Panel Identification

B: On the left side of Flat Roof Panel B between the first two ribs apply a small, evenly distributed bead of sealant over the perimeter of the flat surface. (F17.4)

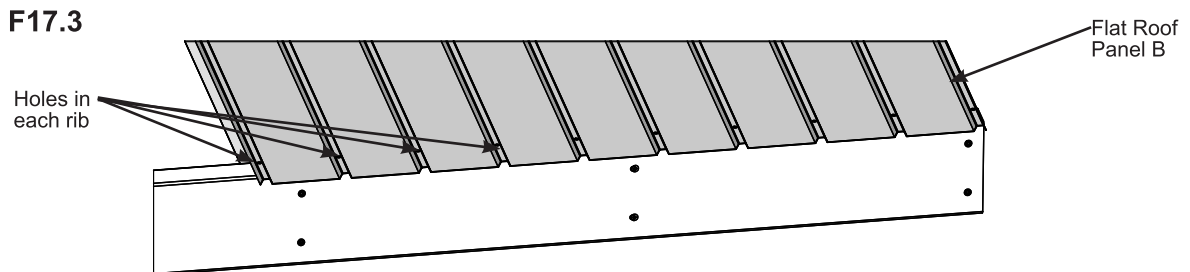
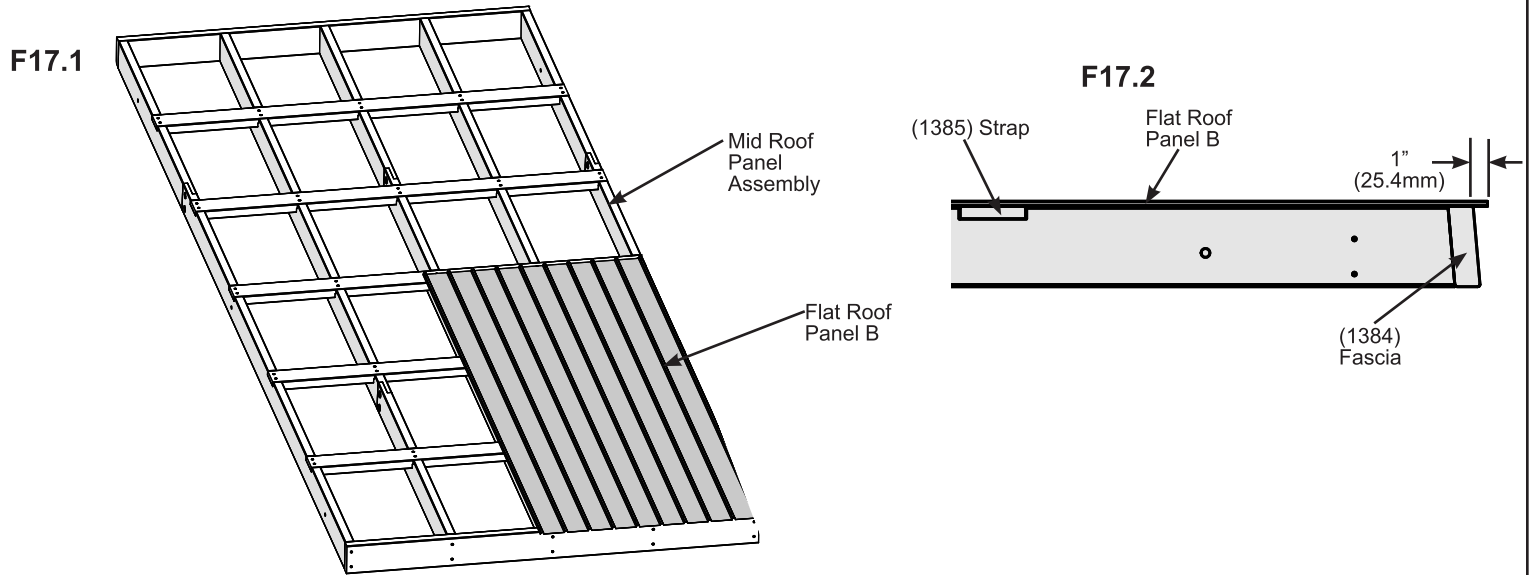

Note: All surfaces to be clean, dry, dust and grease free before application with temperatures above 5°C (41°F), no warmer than 35°C (95°F).

- Apply sealant in small beads and smooth as required.
- Clean excess with a cloth or paper towel before it skins over.
- Always wear safety glasses and rubber gloves when using product.

See page 6 for Warning and First Aid Information.

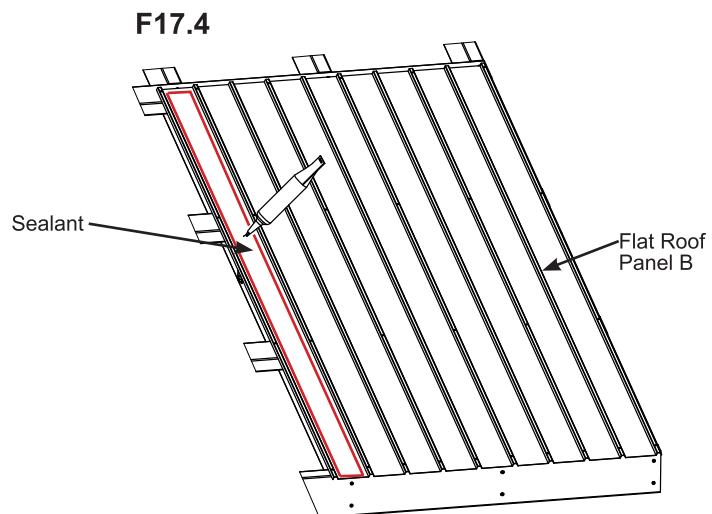

Roof Parts

1 x Flat Roof Panel B
Sealant Tube

Step 17: Attach Roof Panels - Mid Roof Panel Part 2



C: With the holes in every rib on the bottom place one Flat Roof Panel A so it overlaps Flat Roof Panel B by two ribs and the holes are aligned. (F17.5 and F17.6)

Refer to page 36 for Roof Panel Identification

D: Across the top of Flat Roof Panel A and Flat Roof Panel B apply two small, evenly distributed beads of sealant 1-1/2" apart. (F17.7)

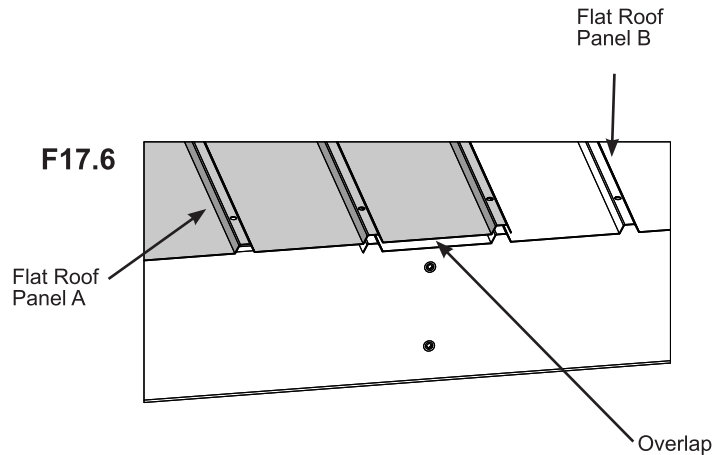
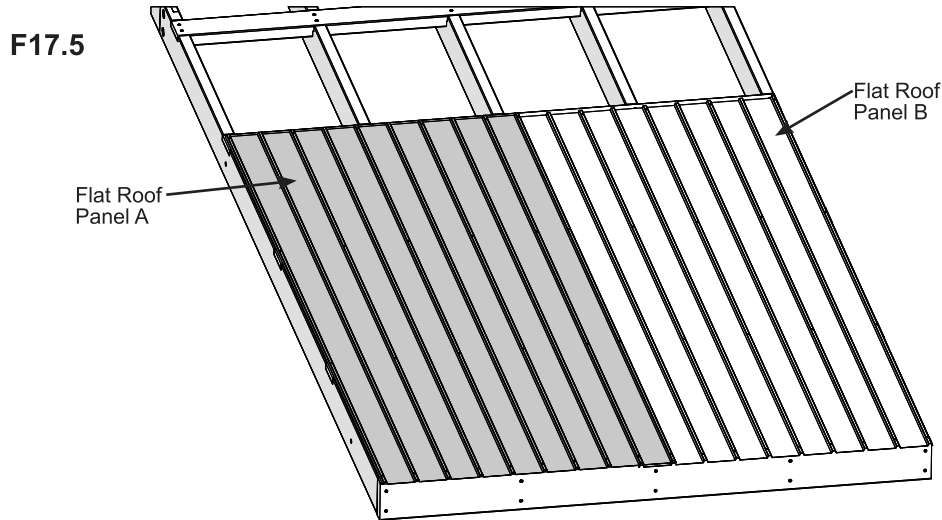

Note: All surfaces to be clean, dry, dust and grease free before application with temperatures above 5°C (41°F), no warmer than 35°C (95°F).

- Apply sealant in small beads and smooth as required.
- Clean excess with a cloth or paper towel before it skins over.
- Always wear safety glasses and rubber gloves when using product.

See page 6 for Warning and First Aid Information.

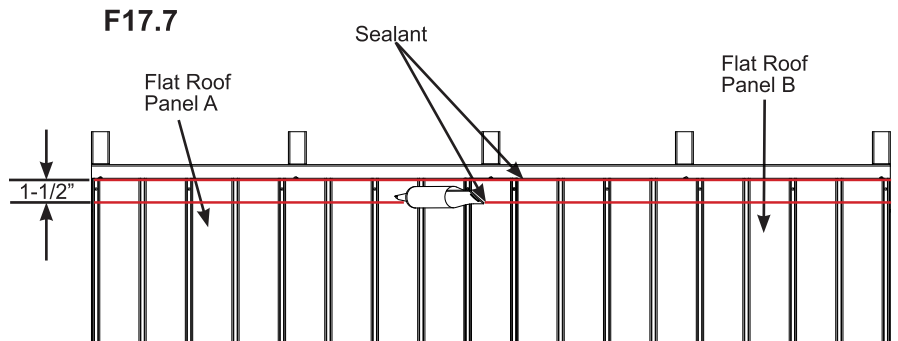

Roof Parts

1 x Flat Roof Panel A

Step 17: Attach Roof Panels - Mid Roof Panel

Part 3

E: With the holes in every rib on the bottom place one Flat Roof Panel B on top of Mid Roof Panel Assembly so the holes align with the top holes in the previously installed Flat Roof Panel B. (F17.8)

Refer to page 36 for Roof Panel Identification

F: On the left side of Flat Roof Panel B between the first two ribs apply a small, evenly distributed bead of sealant over the perimeter of the flat surface. (F17.9)

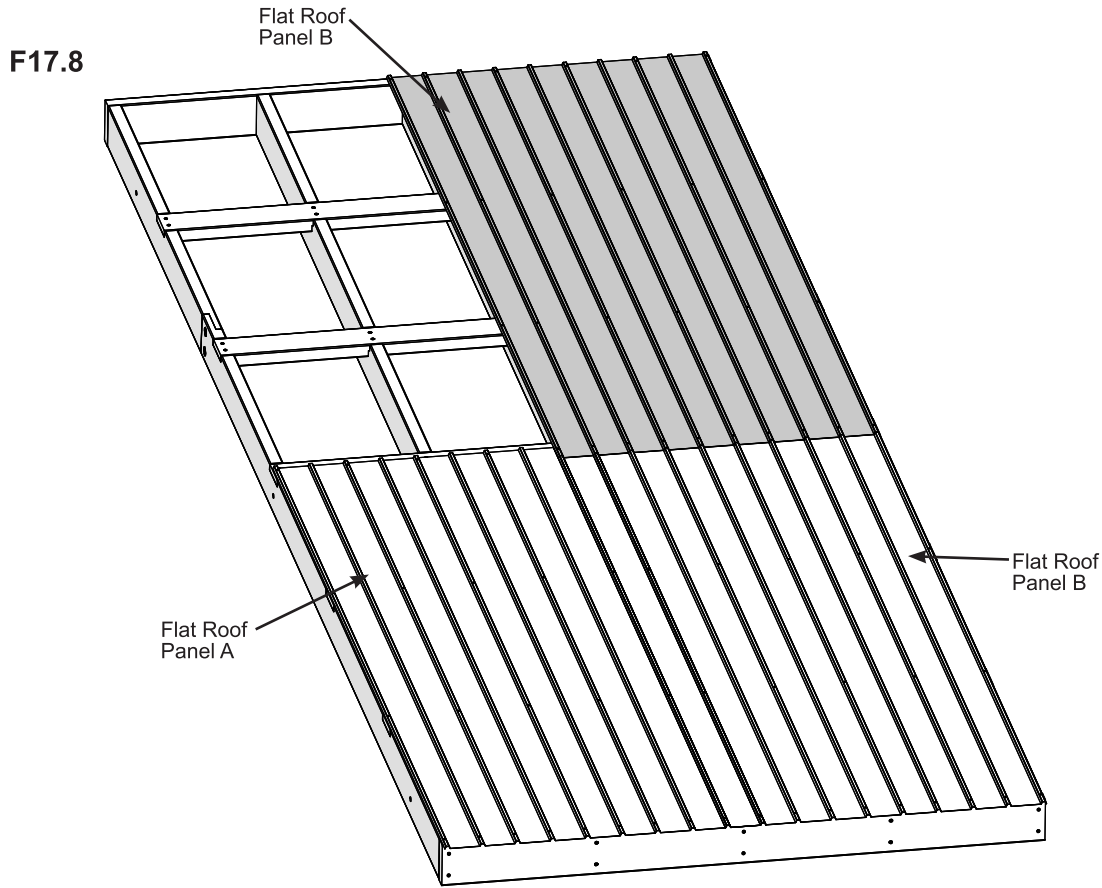

Note: All surfaces to be clean, dry, dust and grease free before application with temperatures above 5°C (41°F), no warmer than 35°C (95°F).

- Apply sealant in small beads and smooth as required.
- Clean excess with a cloth or paper towel before it skins over.
- Always wear safety glasses and rubber gloves when using product.

See page 6 for Warning and First Aid Information.

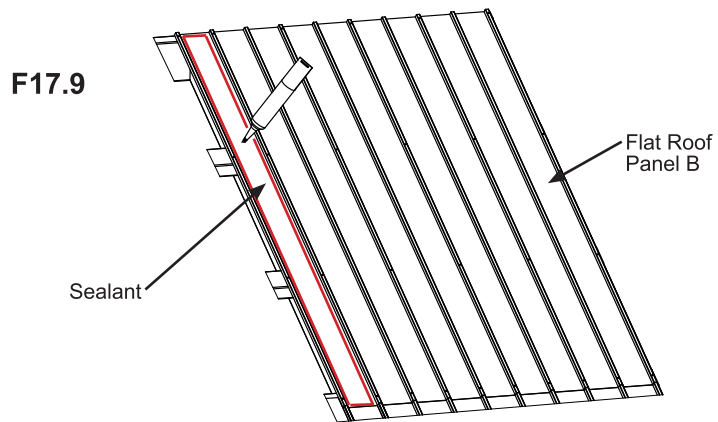

Roof Parts

1 x Flat Roof Panel B

Step 17: Attach Roof Panels - Mid Roof Panel Part 4

G: With the holes in every rib on the bottom place one Flat Roof Panel A so it overlaps Flat Roof Panel B by two ribs and the holes are aligned. (F17.10)

Refer to page 36 for Roof Panel Identification

H: Adjust the Roofing Panels so they are centered on the Mid Panel Assembly and flush to the top. (F17.10)

I: Attach with 56 #8 x 1" Roofing Screws in the locations shown in F17.10. Be sure not to over tighten screws.

F17.10

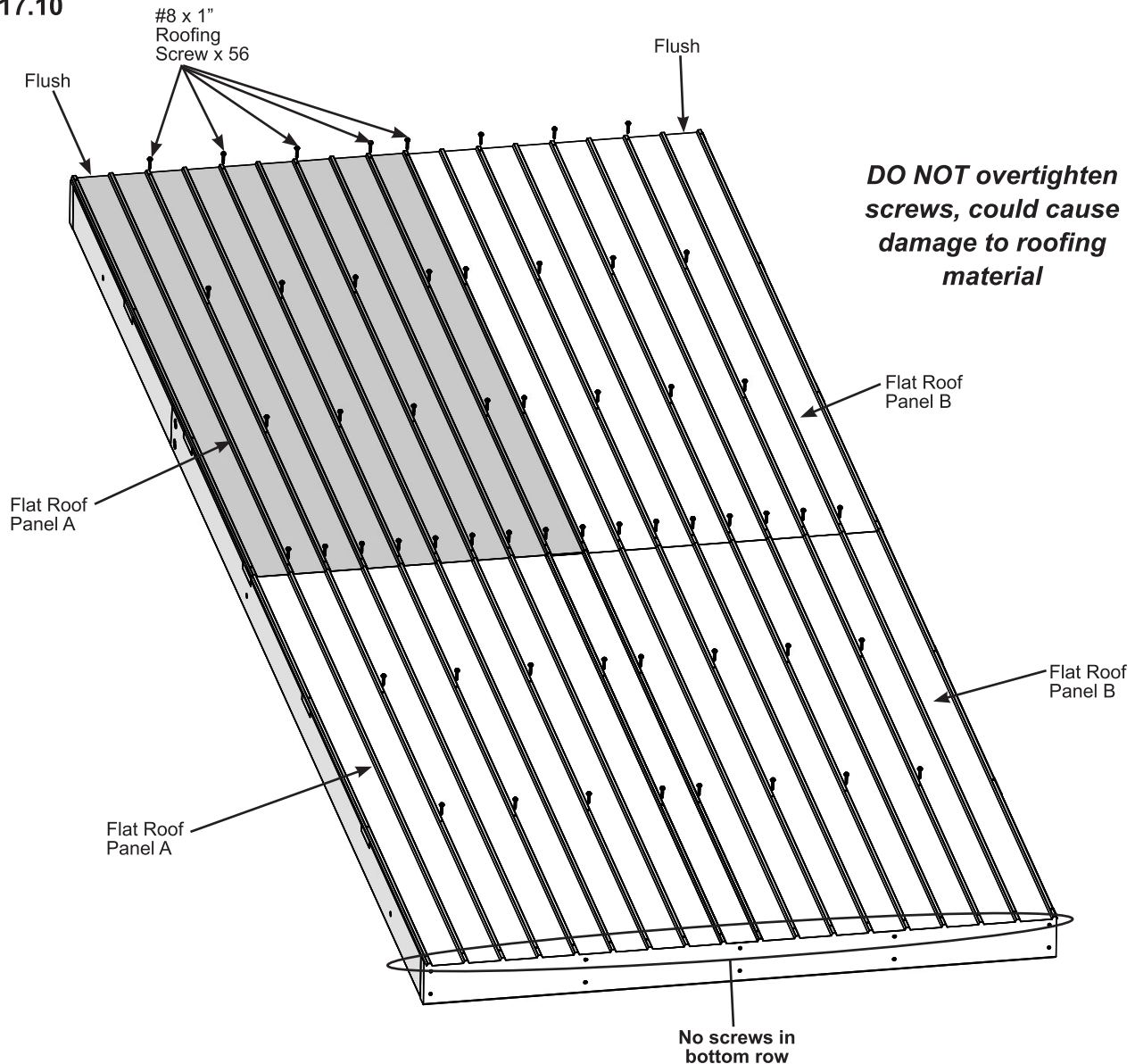

Roof Parts

1 x Flat Roof Panel A

Hardware

56 x #8 x 1" Roofing Screw

Step 17: Attach Roof Panels - Mid Roof Panel

Part 5

J: Apply sealant to the inside groove of two Flat Roof Clip - Shorts and two Flat Roof Clip Longs. (F17.11)

K: Place one Flat Roof Clip - Short on the outside rib of Flat Roof Panel A with the flange facing inward. Ensure holes are aligned and install with three #8 x 1" Roofing Screws. (F17.12 and F17.13)

L: Place one Flat Roof Clip - Long on the outside rib of Flat Roof Panel A with holes aligned and tight to Flat Roof Clip - Short. Attach with nine #8 x 1" Roofing Screws. (F17.14 and F17.16)

M: Place one Flat Roof Clip - Long on the outside rib of Flat Roof Panel B with the flange facing inward. Ensure holes are aligned and install with seven #8 x 1" Roofing Screws. (F17.12)

N: Place one Flat Roof Clip - Short on the outside rib of Flat Roof Panel B with holes aligned and tight to Flat Roof Clip - Long. Attach with five #8 x 1" Roofing Screws. (F17.12 and F17.15) **NOTE:** Only every other hole lines up with the holes in the Roof Panels.

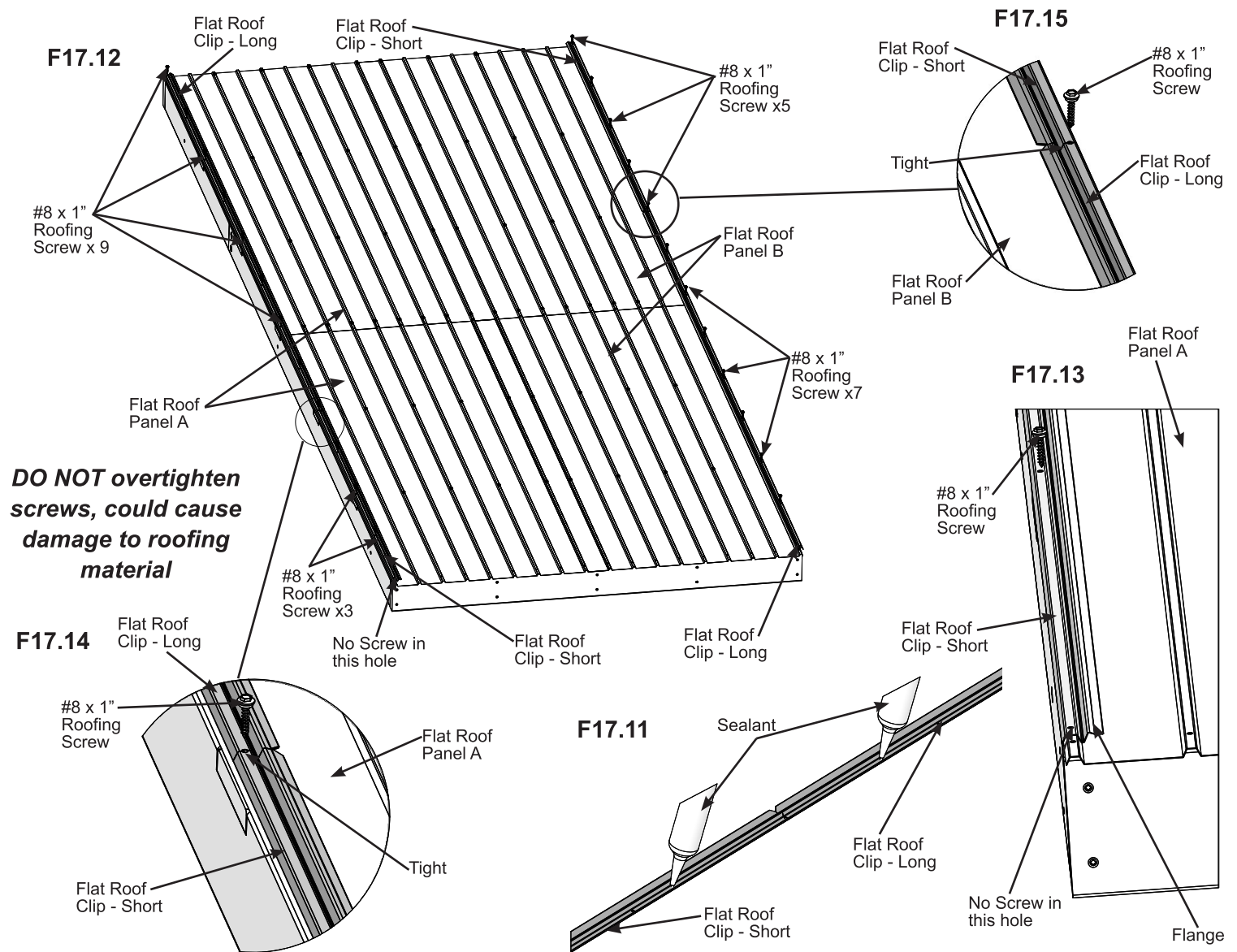

Roof Parts

- 2 x Flat Roof Clip - Short
- 2 x Flat Roof Clip - Long

Hardware

- 24 x #8 x 1" Roofing Screw

Step 18: Right Roof Panel Assembly

Part 2

C: On each end of the Rafter Assemblies place one (1384) Fascia so that the top is level with the Rafter Assemblies and the outside edges are flush. (F18.3, F18.4 and F18.5)

D: Attach (1384) Fascia to Rafter Assemblies with 10 #8 x 2-1/2" Wood Screws per Fascia. (F18.3 and F18.4)

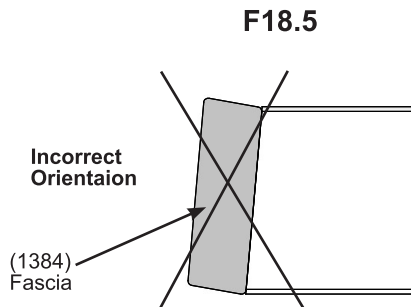
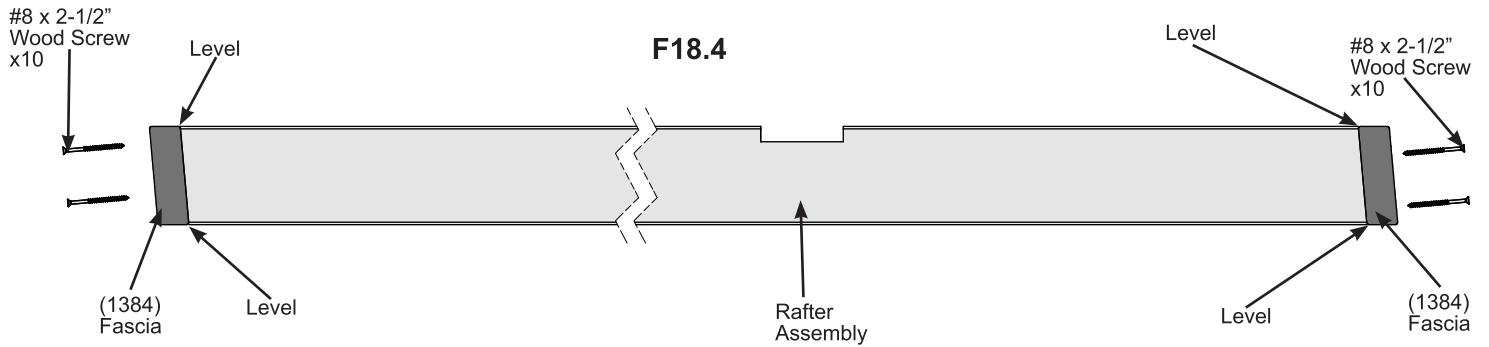
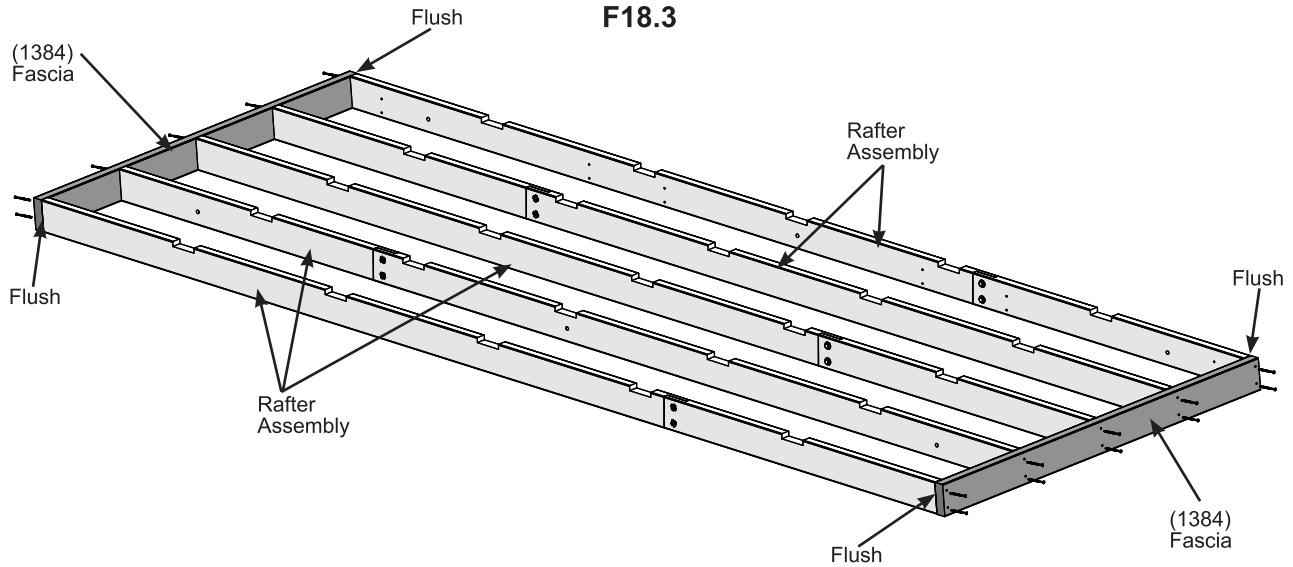

Wood Parts

2 x (1384) Fascia

Hardware

20 x #8 x 2-1/2" Wood Screw

Step 18: Right Roof Panel Assembly Part 3

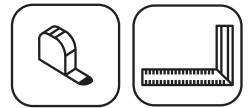

E: Place five (1385) Straps in the notches of each rafter assembly so the ends are flush to the outside edges of the outside rafter assemblies. (F18.7)

F: Make sure the Rafter Assembly is square. The diagonal distance between the corners of the Fascia's is 155-1/8" [3.940m]. Attach (1385) Straps to Rafter Assemblies with 10 #8 x 1-1/2" Wood Screws per strap. (F18.6, F18.7 and F18.8)

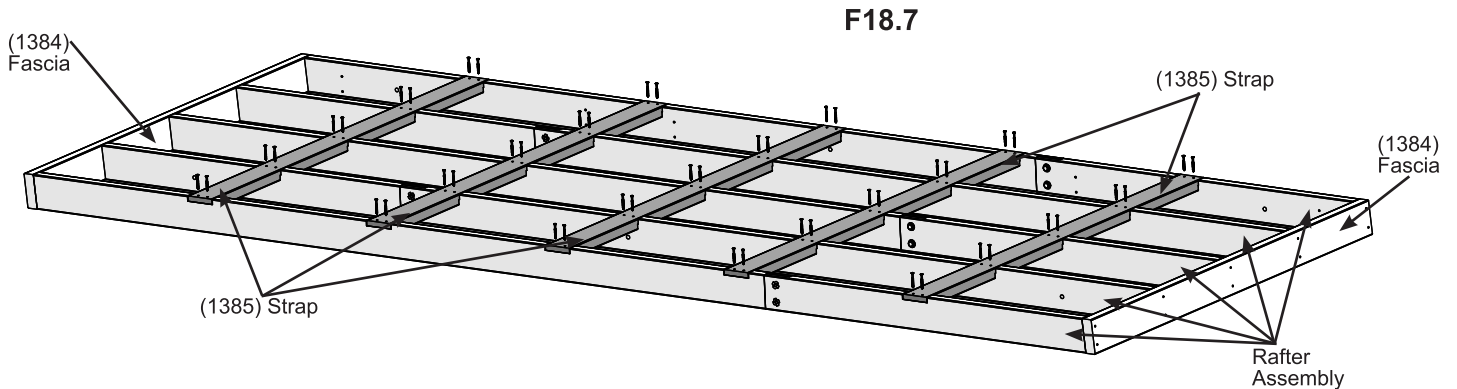
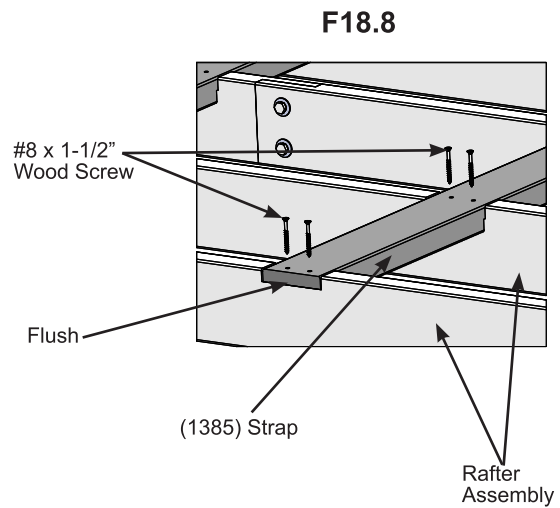
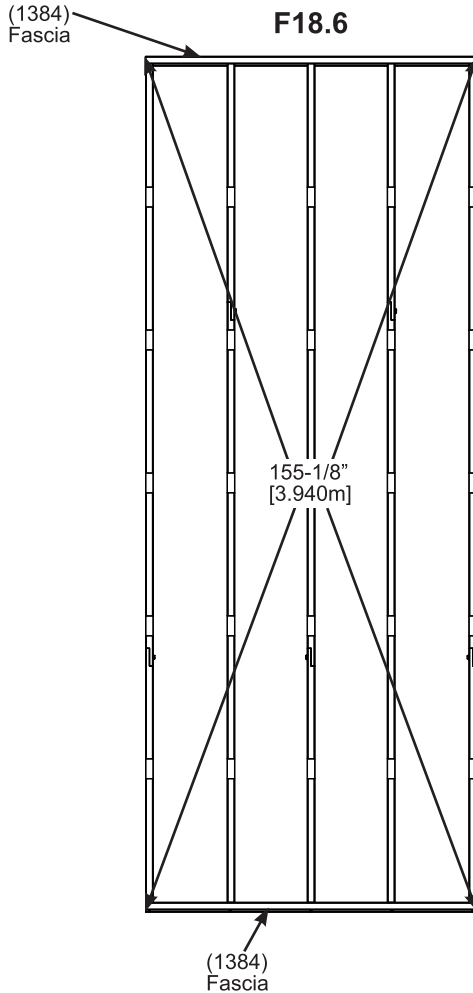

Wood Parts

5 x (1385) Strap

Hardware

50 x #8 x 1-1/2" Wood Screw

Step 18: Right Roof Panel Assembly Part 4

G: On the right side of (1389) Rafter Long Bottom B under the middle (1385) Strap attach one Truss Bracket using one 5/16 x 1-1/2" Hex Bolt (with 5/16" lock washer, 5/16" flat washer and 5/16" t-nut). (F18.9 and F18.10)

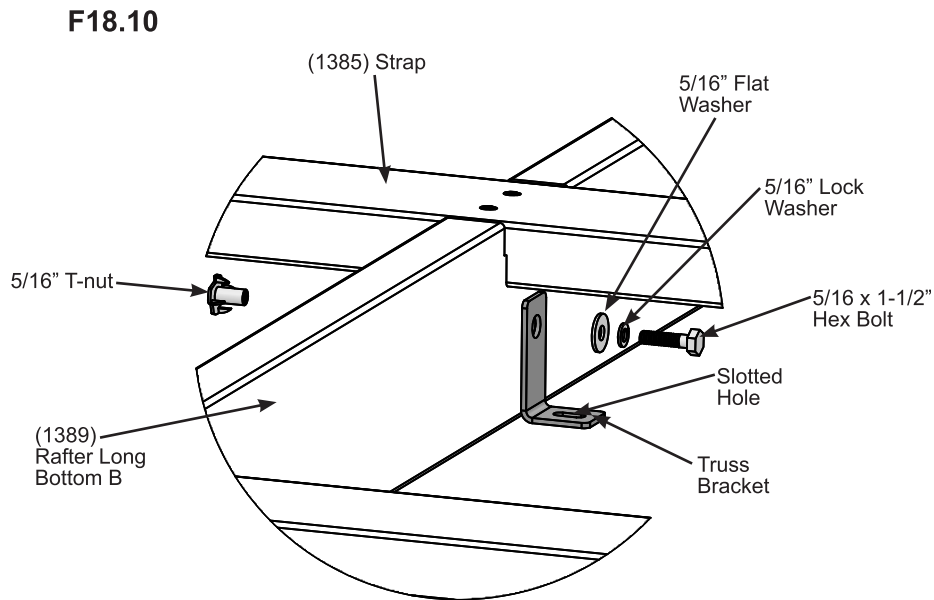
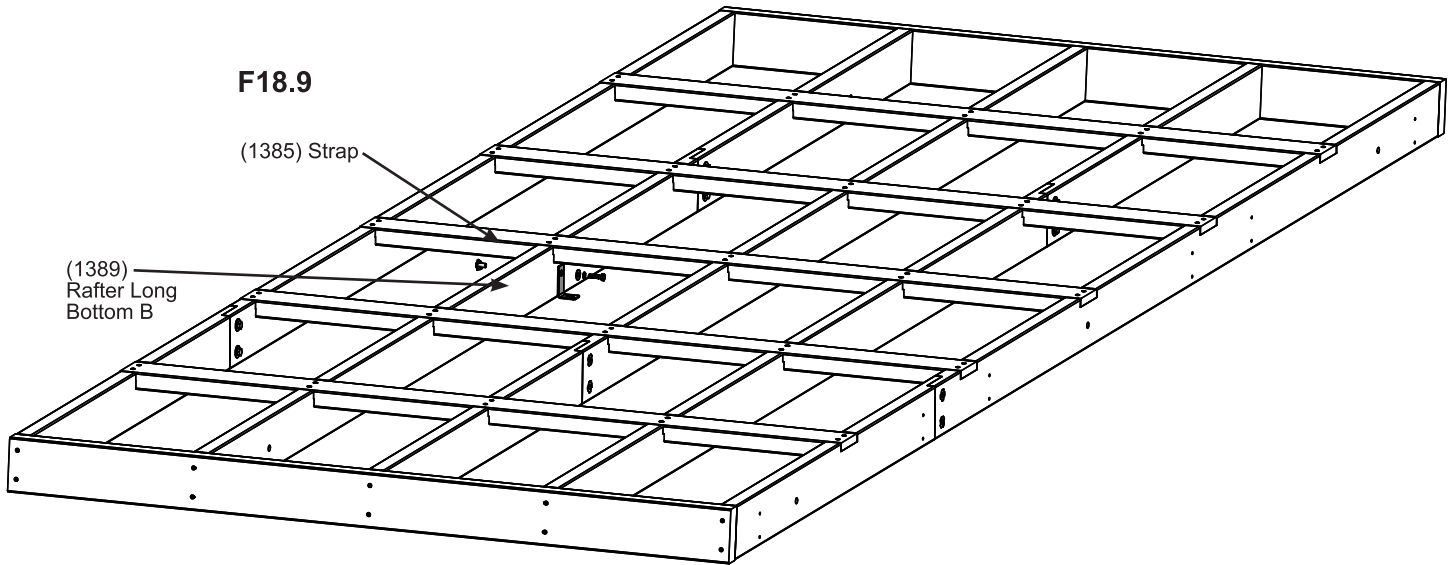

Components

1 x Truss Bracket

Hardware

1 x 5/16 x 1-1/2" Hex Bolt
(5/16" lock washer, 5/16" flat washer and 5/16" t-nut)

Step 18: Right Roof Panel Assembly Part 5



H: Flip Roof Panel over and install three (1394) Roof Eave Supports centered on the middle three (1385) Straps between (1389) Rafter Long Bottom B and (1392) Rafter Long Top A with two #8 x 3-1/2" Wood Screws per Support. (F18.11, F18.12 and F18.13)

F18.11

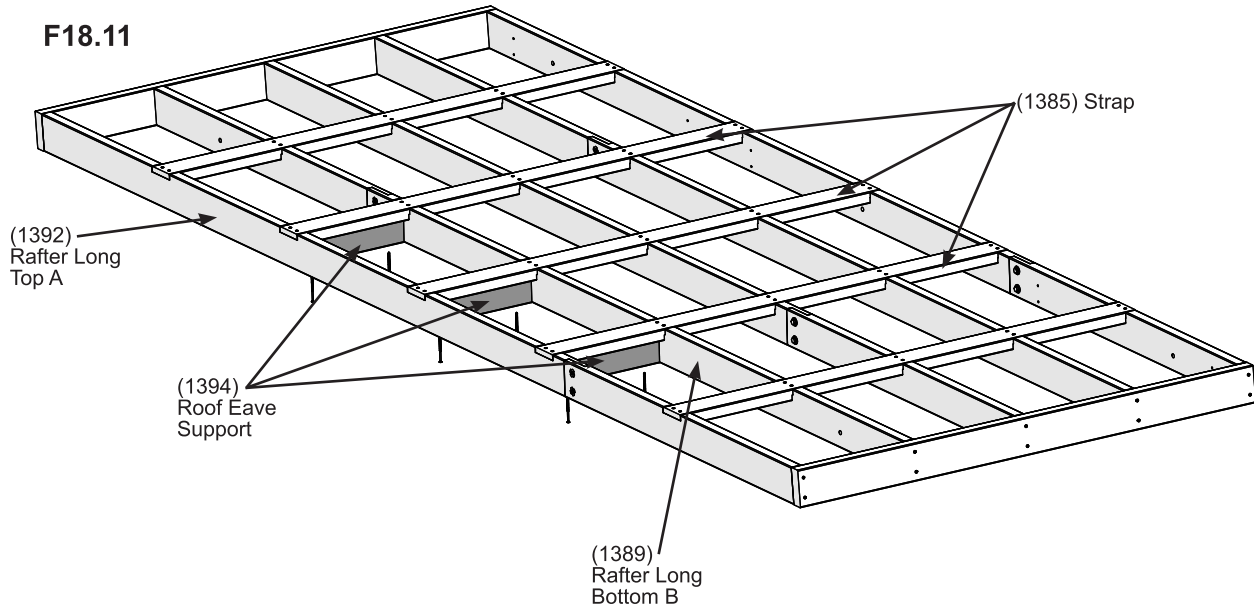

F18.12

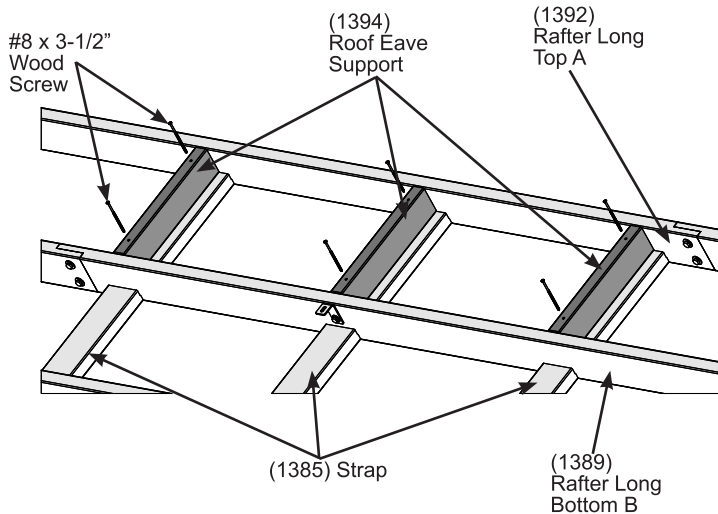

F18.13

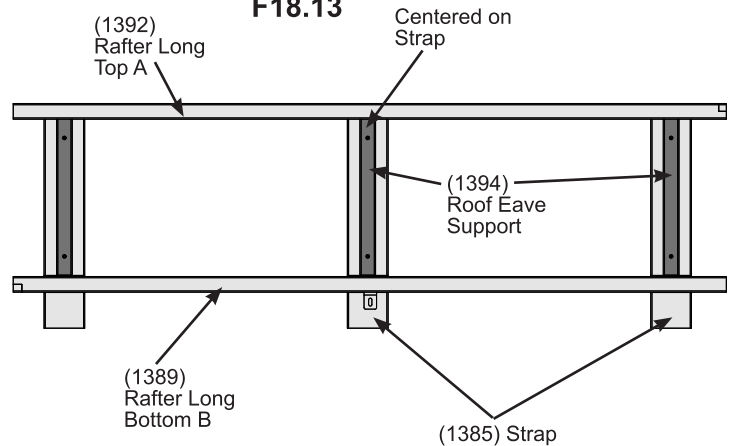

Wood Parts

3 x (1394) Roof Eave Support

Hardware

6 x #8 x 3-1/2" Wood Screw

Step 19: Attach Roof Panels - Right Roof Panel Part 1



A: Place one Flat Roof Panel B on top of Right Roof Panel Assembly so the end with the holes in each rib are at the bottom. (F19.1, F19.2 and F19.3) The Roof Panel should overhang 1" (25.4mm) along the bottom. Refer to page 36 for Roof Panel Identification

B: On the left side of Flat Roof Panel B between the first two ribs apply a small, evenly distributed bead of sealant over the perimeter of the flat surface. (F19.4)

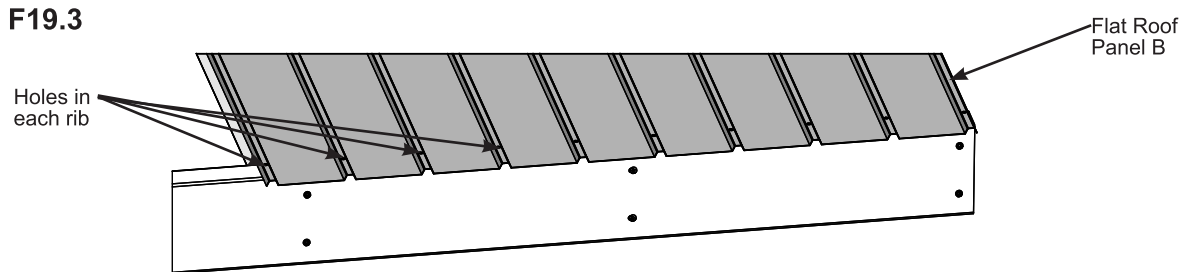
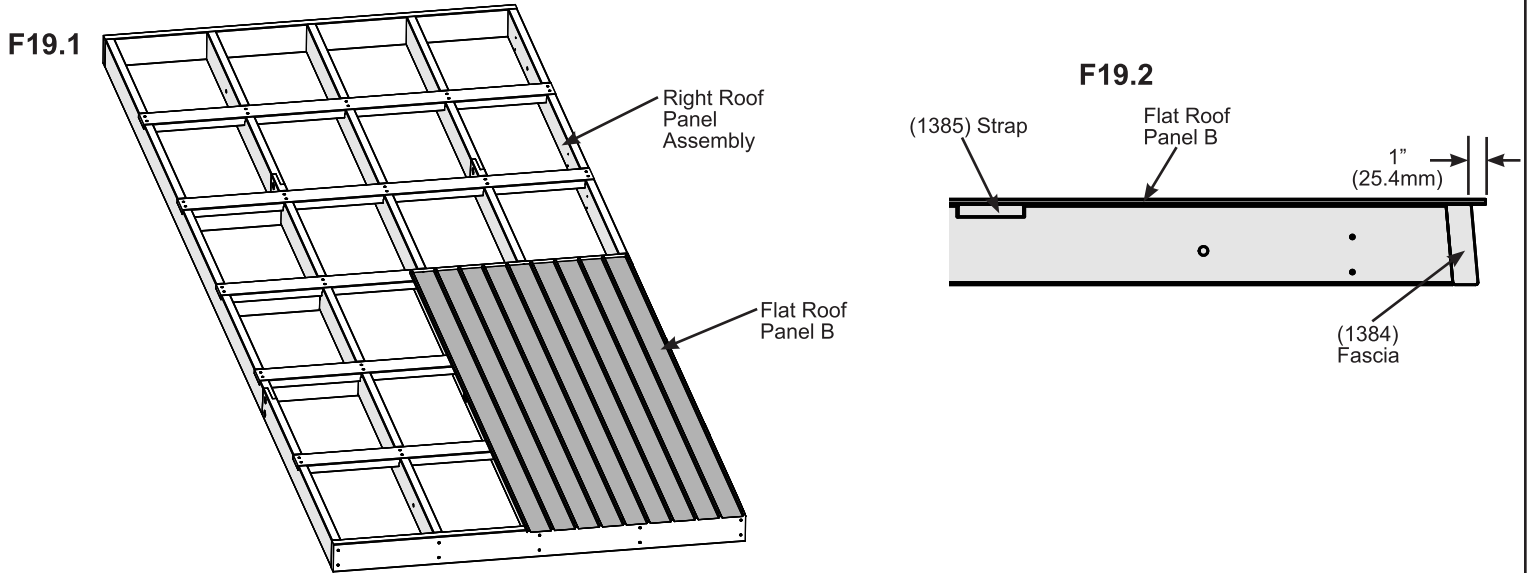

Note: All surfaces to be clean, dry, dust and grease free before application with temperatures above 5°C (41°F), no warmer than 35°C (95°F).

- Apply sealant in small beads and smooth as required.
- Clean excess with a cloth or paper towel before it skins over.
- Always wear safety glasses and rubber gloves when using product.

See page 6 for Warning and First Aid Information.

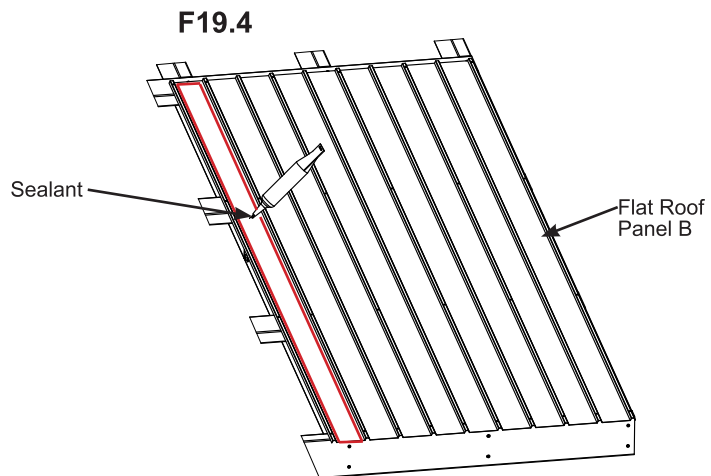

Roof Parts

- 1 x Flat Roof Panel B
- Sealant Tube

Step 19: Attach Roof Panels - Right Roof Panel Part 2



C: With the holes in every rib on the bottom place one Flat Roof Panel A so it overlaps Flat Roof Panel B by two ribs and the holes are aligned. (F19.5 and F19.6)

Refer to page 36 for Roof Panel Identification

D: Across the top of Flat Roof Panel A and Flat Roof Panel B apply two small, evenly distributed beads of sealant 1-1/2" apart. (F19.7)

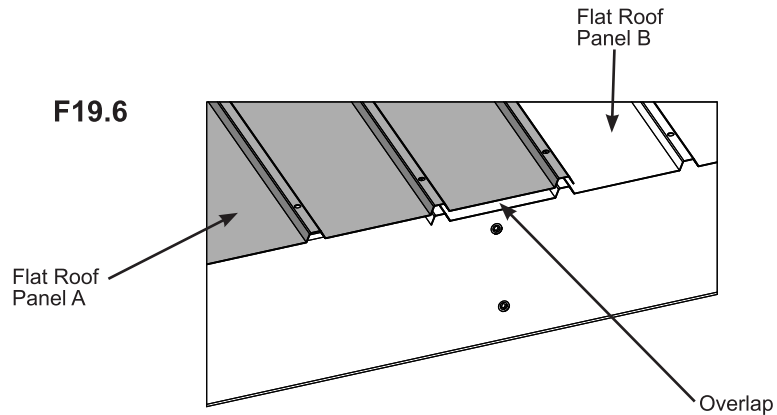
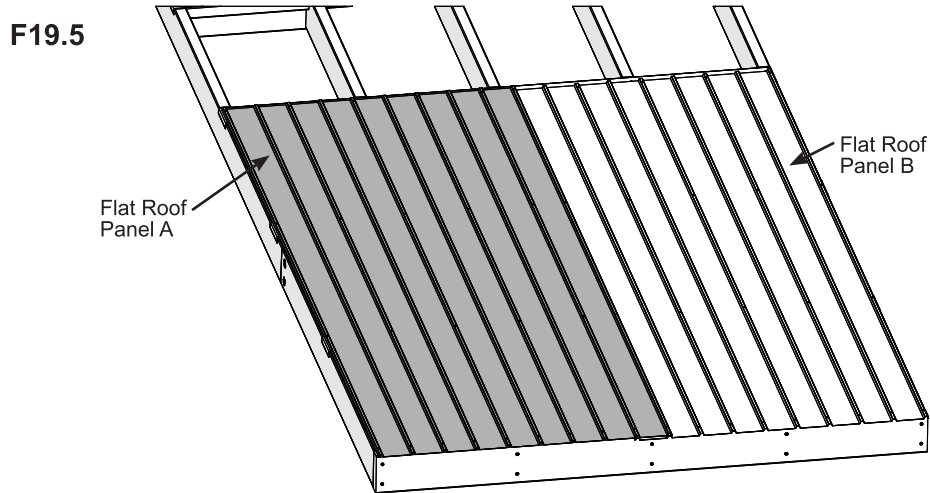

Note: All surfaces to be clean, dry, dust and grease free before application with temperatures above 5°C (41°F), no warmer than 35°C (95°F).

- Apply sealant in small beads and smooth as required.
- Clean excess with a cloth or paper towel before it skins over.
- Always wear safety glasses and rubber gloves when using product.

See page 6 for Warning and First Aid Information.

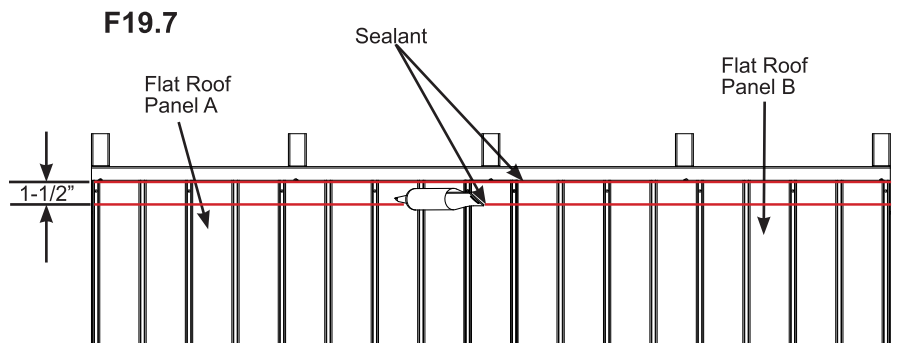

Roof Parts

1 x Flat Roof Panel A

Step 19: Attach Roof Panels - Right Roof Panel

Part 3

E: With the holes in every rib on the bottom place one Flat Roof Panel B on top of Left Roof Panel Assembly so the holes align with the top holes in the previously installed Flat Roof Panel B. (F19.8)

Refer to page 36 for Roof Panel Identification

F: On the left side of Flat Roof Panel B between the first two ribs apply a small, evenly distributed bead of sealant over the perimeter of the flat surface. (F19.9)

F19.8

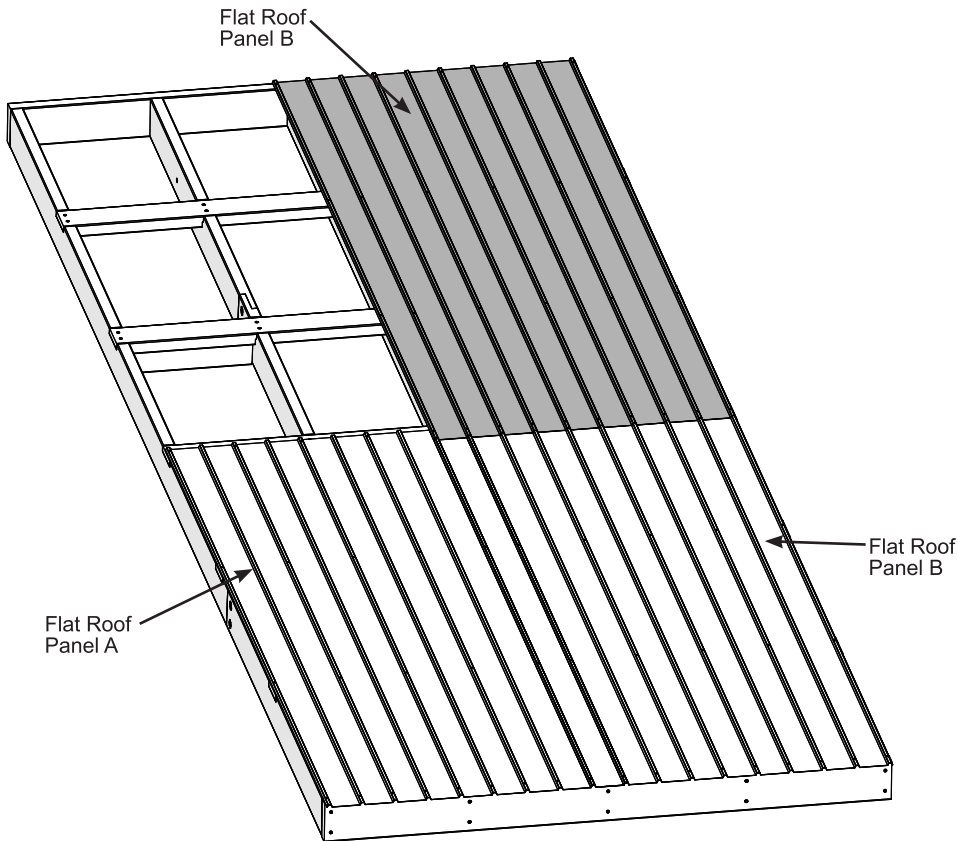

Note: All surfaces to be clean, dry, dust and grease free before application with temperatures above 5°C (41°F), no warmer than 35°C (95°F).

- Apply sealant in small beads and smooth as required.
- Clean excess with a cloth or paper towel before it skins over.
- Always wear safety glasses and rubber gloves when using product.

See page 6 for Warning and First Aid Information.

F19.9

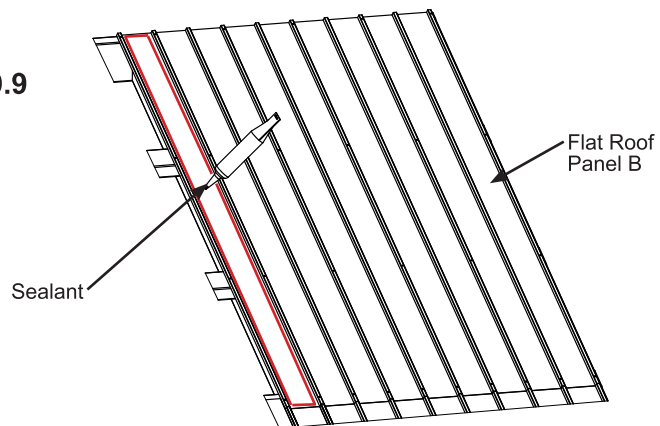

Roof Parts

1 x Flat Roof Panel B

Step 19: Attach Roof Panels - Right Roof Panel Part 4

G: With the holes in every rib on the bottom place one Flat Roof Panel A so it overlaps Flat Roof Panel B by two ribs and the holes are aligned. (F19.10)

Refer to page 36 for Roof Panel Identification

H: Adjust the Roofing Panels so they are flush to the top and right side of the Panel Assembly. (F19.10)

I: Attach with 62 #8 x 1" Roofing Screws in the locations shown in F19.10. Be sure not to over tighten screws.

F19.10

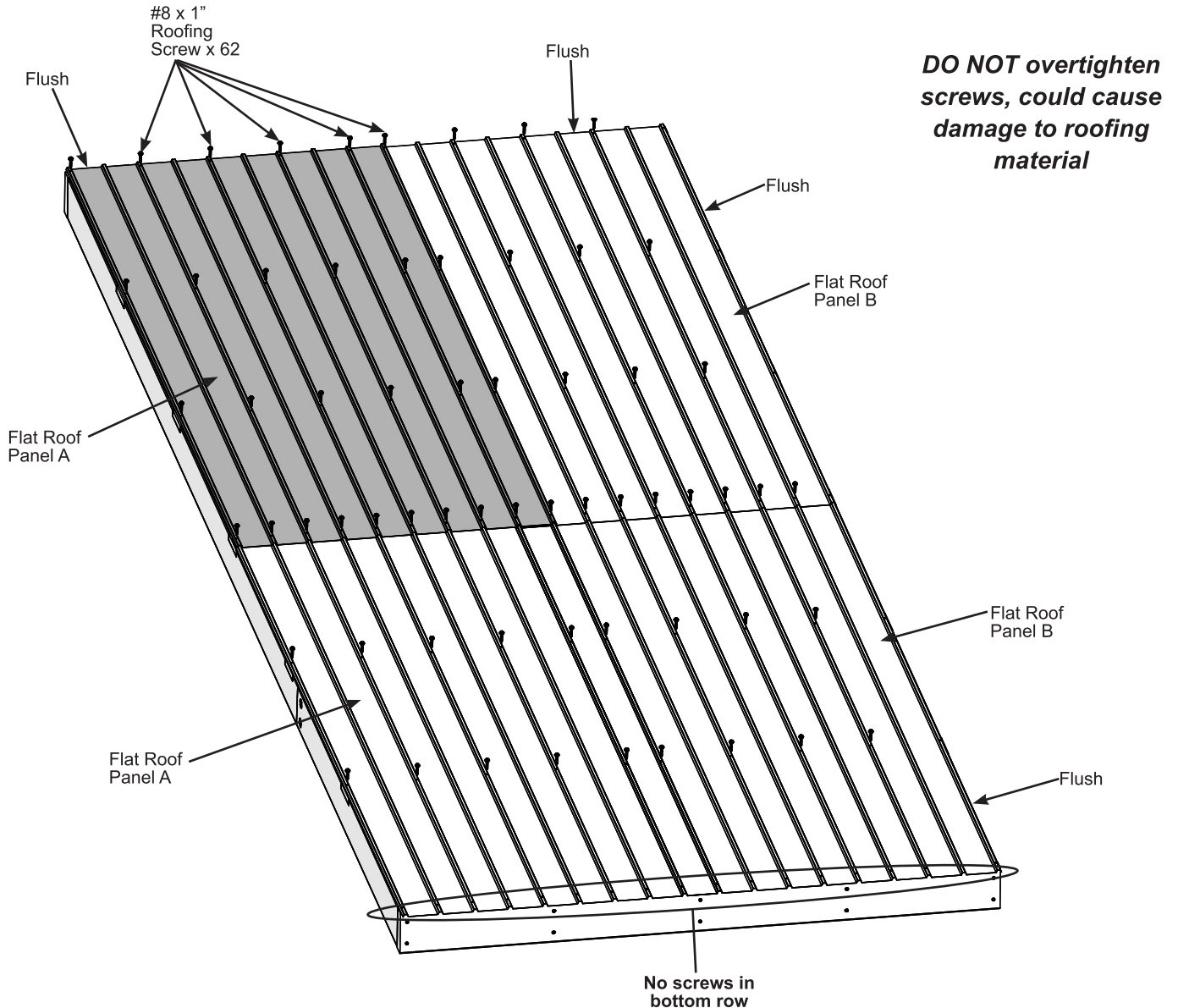

Roof Parts

1 x Flat Roof Panel A

Hardware

62 x #8 x 1" Roofing Screw

Step 19: Attach Roof Panels - Right Roof Panel Part 5

J: Apply sealant to the inside groove of the Flat Roof Clip - Short and Flat Roof Clip Long. (F19.11)

K: Place one Flat Roof Clip - Long on the outside rib of Flat Roof Panel B with the flange facing inward. Ensure holes are aligned and install with seven #8 x 1" Roofing Screws. (F19.12 and F19.13)

L: Place one Flat Roof Clip - Short on the outside rib of Flat Roof Panel B with holes aligned and tight to Flat Roof Clip - Long. Attach with five #8 x 1" Roofing Screws. (F19.12 and F19.14)

NOTE: Only every other hole lines up with the holes in the Roof Panels.

F19.14

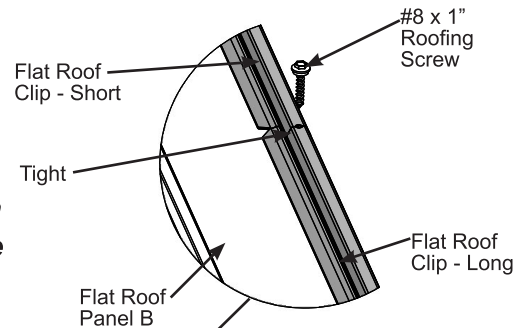

F19.11

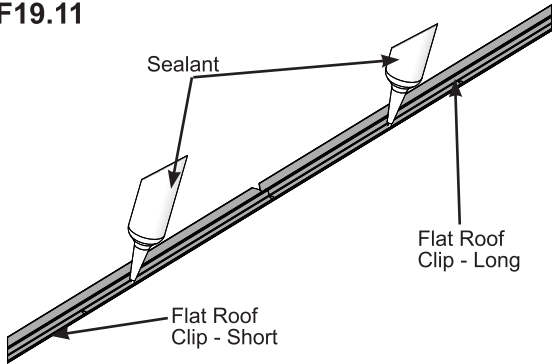

DO NOT overtighten screws, could cause damage to roofing material

F19.12

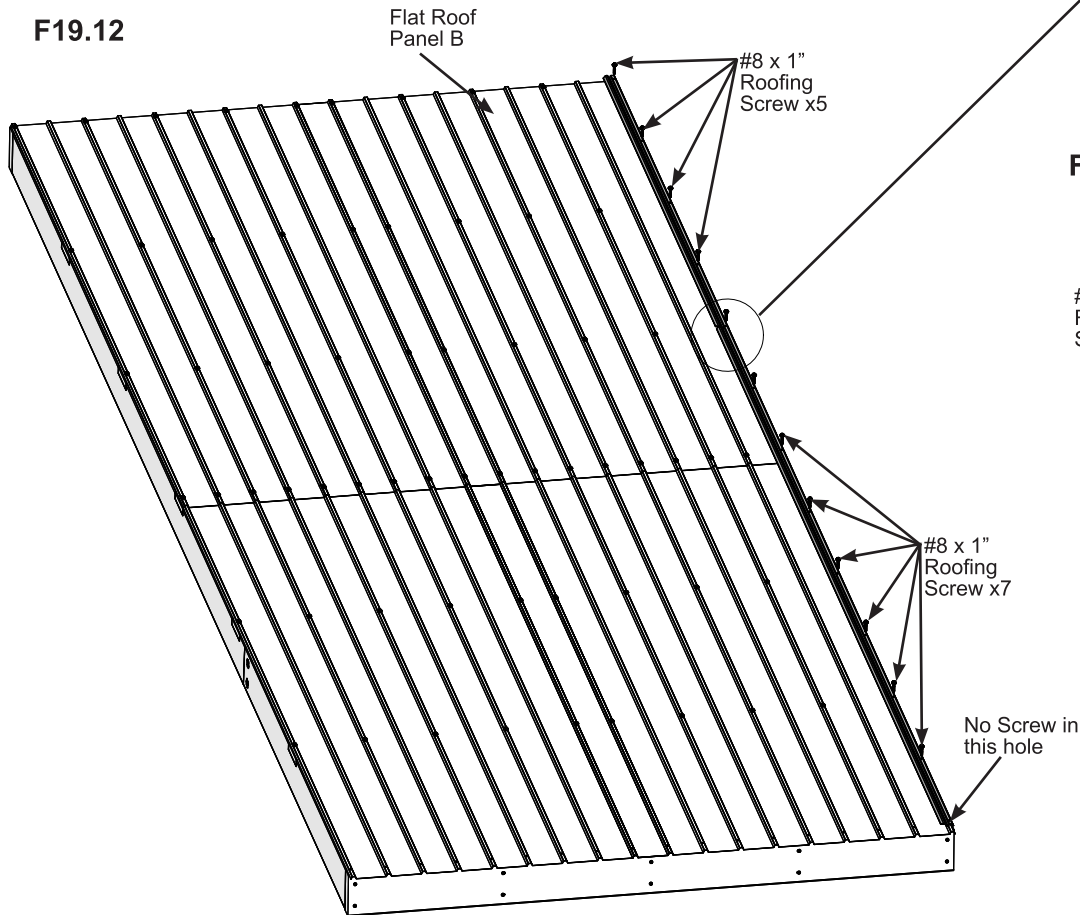

F19.13

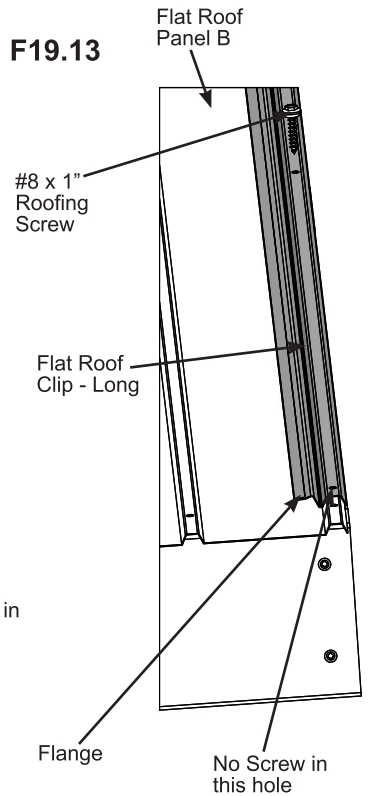

Roof Parts

- 1 x Flat Roof Clip - Short
- 1 x Flat Roof Clip - Long

Hardware

- 12 x #8 x 1" Roofing Screw

Step 20: Attach Roof Panels

Part 1

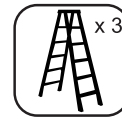

A: With all four assemblers lift the Left Roof Panel Assembly onto the Truss Assemblies so the end with the roofing overhang is at the back and (1386) Rafter Short Top B and (1389) Rafter Long Bottom B are tight to the inside of the Front Left Post Assembly and Back Post Assembly. (F20.1 and F20.2)

B: Attach Left Roof Panel Assembly to the Front Left Post Assembly and Back Post Assembly using one 3/8 x 9" Hex Bolt (with two 3/8" large washer and 3/8" lock nut) per Post. (F20.1 and F20.3)

F20.1

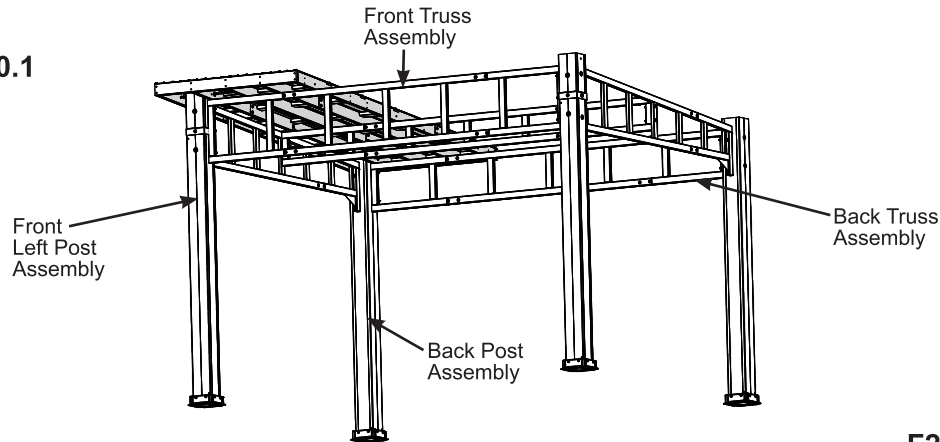

F20.2

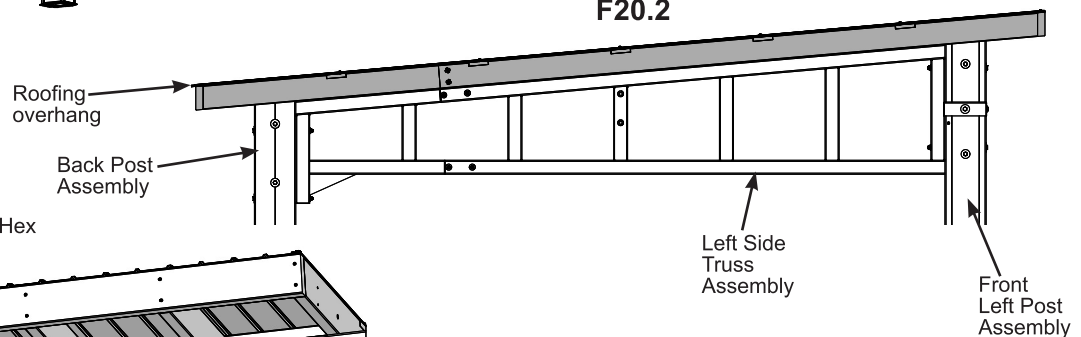

F20.3

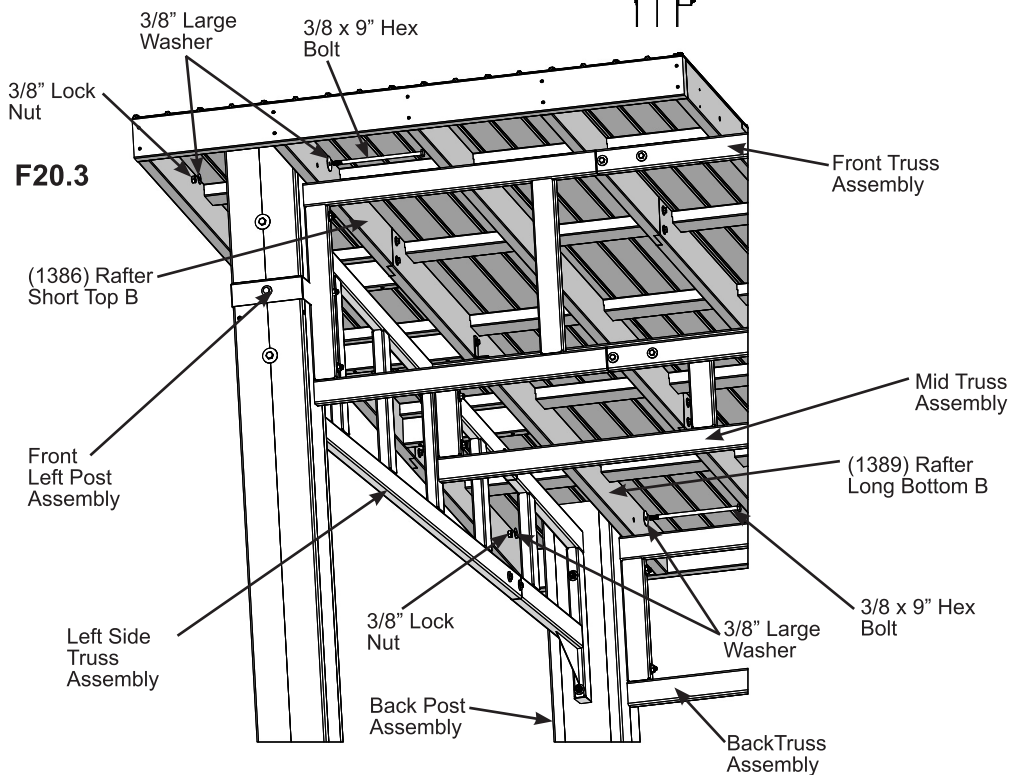

Hardware

2 x 3/8 x 9" Hex Bolt
(3/8" large washer x 2, 3/8" lock nut)

Step 20: Attach Roof Panels

Part 2



C: Place one Truss Bracket on the Front, Mid and Back Truss Assemblies with the slot lining up with the hole in the Trusses. Loosely attach Truss Bracket to the Truss Assemblies using one 1/4 x 3" Hex Bolt (with 1/4" flat washer x 2 and 1/4" lock Nut) per bracket. (F20.4 and F20.5)

D: Loosely attach previously installed Truss Bracket to Mid Truss Assembly using one 1/4 x 3" Hex Bolt (with 1/4" flat washer x 2 and 1/4" lock Nut) (F20.4 and F20.6)

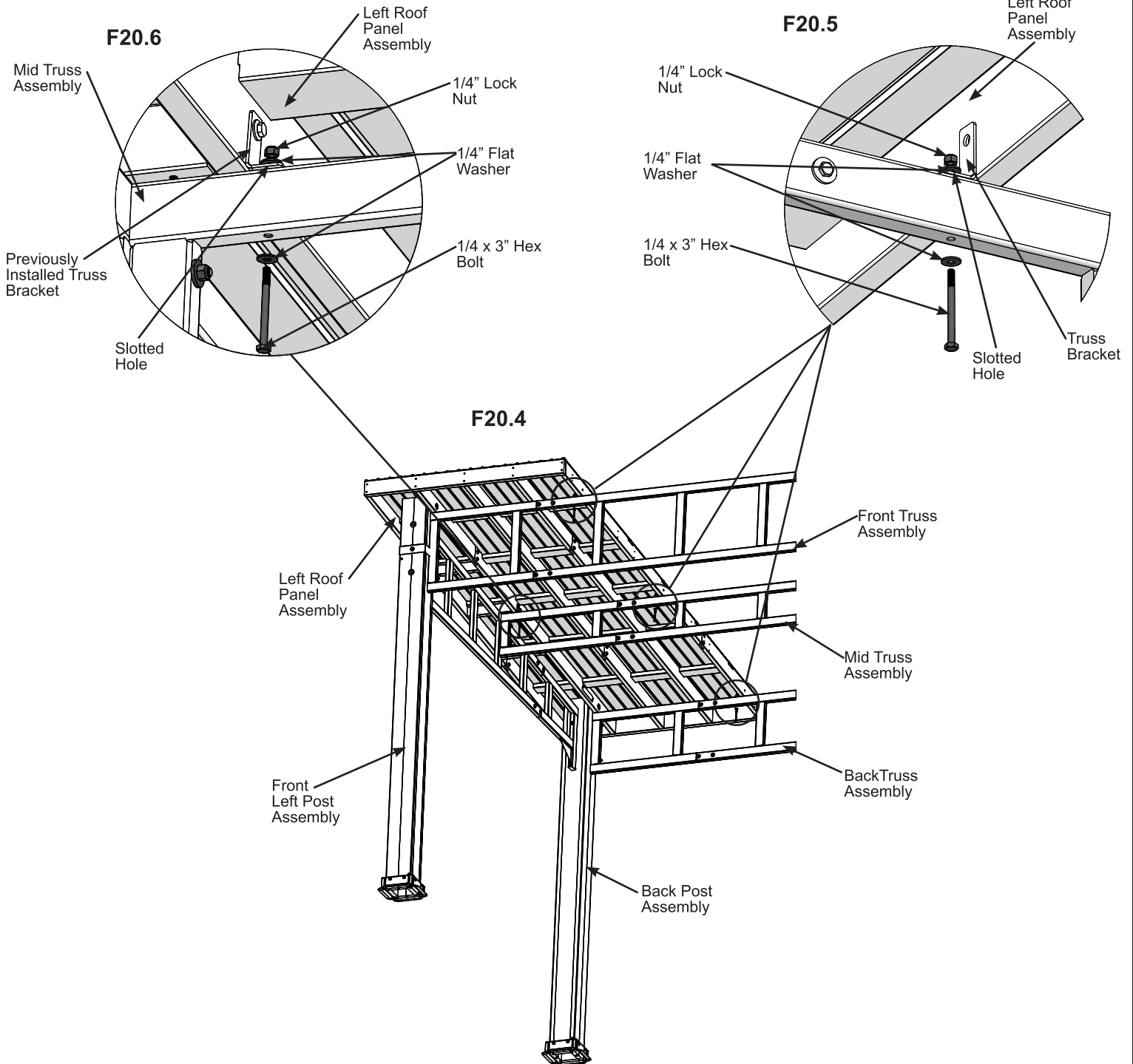

Components

3 x Truss Bracket

Hardware

4 x 1/4 x 3" Hex Bolt
(1/4" flat washer x 2, 1/4" lock nut)

Step 20: Attach Roof Panels

Part 3

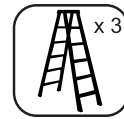

E: With all four assemblers lift the Mid Roof Panel Assembly onto the Truss Assemblies so the end with the roofing overhang is at the back and lines up with the Left Roof Panel Assembly. (F20.7)

F: Connect Left Roof Panel Assembly and Mid Roof Panel Assembly through the Rafters and Truss Brackets using three 5/16 x 3-1/4" Hex Bolt (with 5/16" flat washer, 1/4-5/16" large washer and 5/16" lock nut) (F20.7 and F20.8)

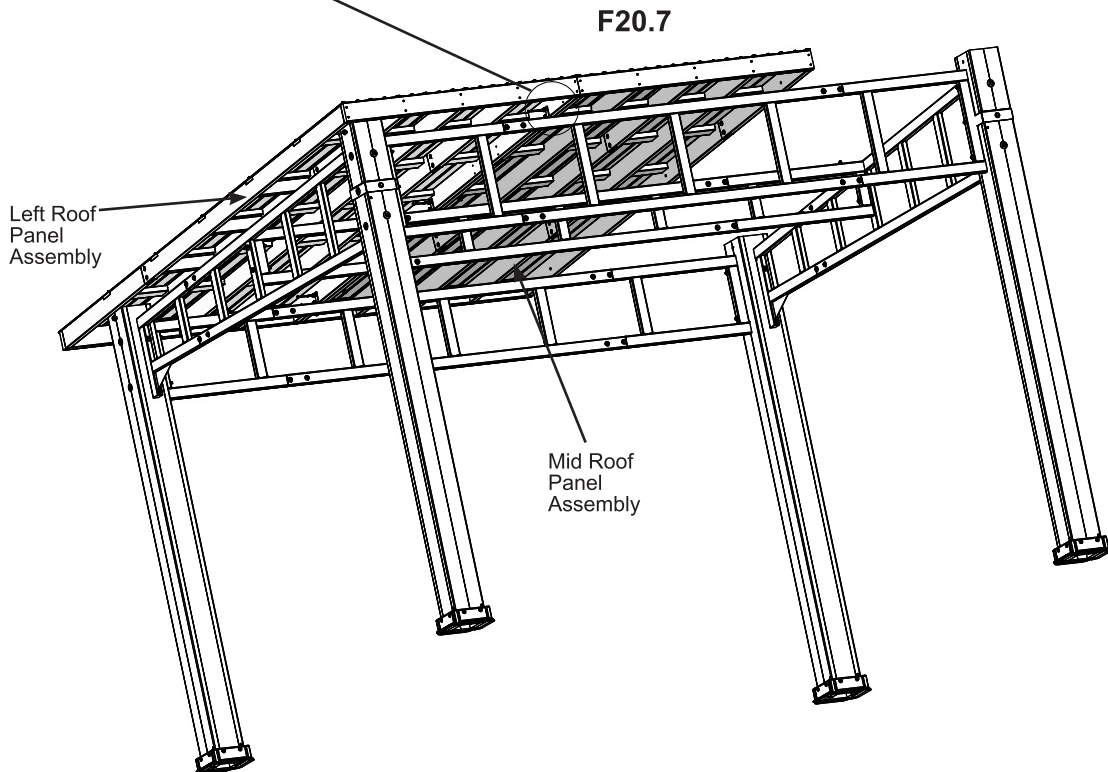
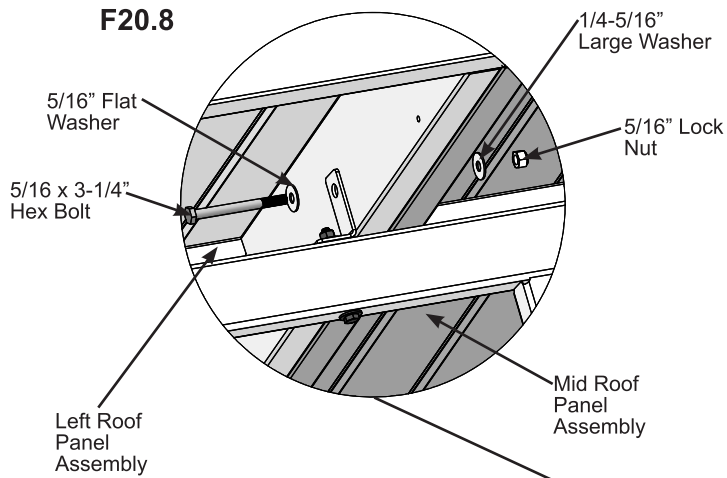

Hardware

3 x 5/16 x 3-1/4" Hex Bolt
(5/16" flat washer, 1/4-5/16" large washer and 5/16 lock nut)

Step 20: Attach Roof Panels

Part 4

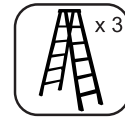

G: With all four assemblers lift the Right Roof Panel Assembly onto the Truss Assemblies so the end with the roofing overhang is at the back and lines up with the Mid Roof Panel Assembly. (F20.9)

H: Attach Right Roof Panel Assembly to the Front Right Post Assembly and Back Post Assembly using one 3/8 x 9" Hex Bolt (with two 3/8" large washer and 3/8" lock nut) per Post. (F20.9, F20.10 and F20.11)

F20.9

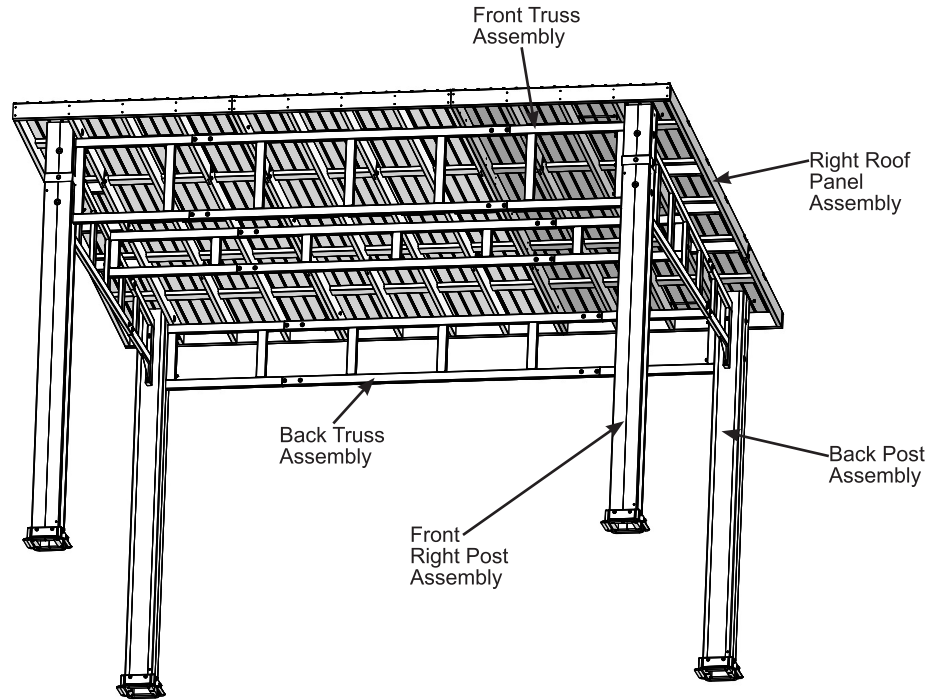

F20.10

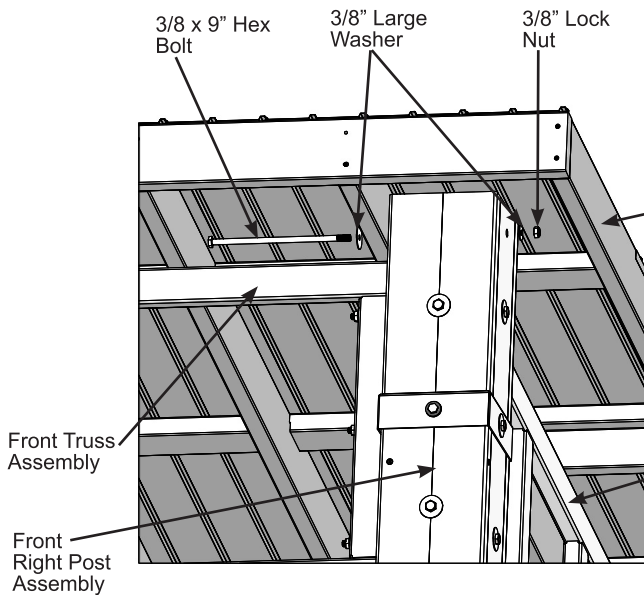

F20.11

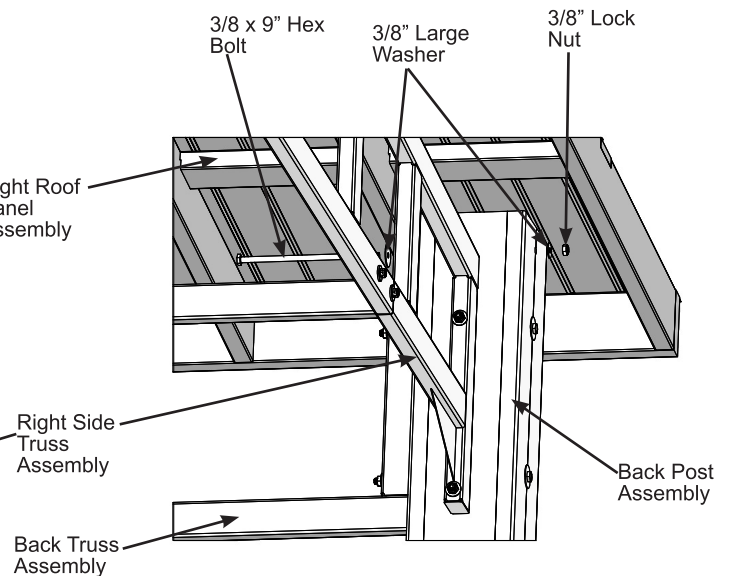

Hardware

2 x 3/8 x 9" Hex Bolt
(3/8" large washer x 2, 3/8" lock nut)

Step 20: Attach Roof Panels



Part 5

I: Place one Truss Bracket on the Front, Mid and Back Truss Assemblies with the slot lining up with the hole in the Trusses. Loosely attach Truss Bracket to the Truss Assemblies using one 1/4 x 3" Hex Bolt (with 1/4" flat washer x 2 and 1/4" lock Nut) per bracket. (F20.12 and F20.13)

J: Loosely attach previously installed Truss Bracket to Mid Truss Assembly using one 1/4 x 3" Hex Bolt (with 1/4" flat washer x 2 and 1/4" lock Nut) (F20.12 and F20.14)

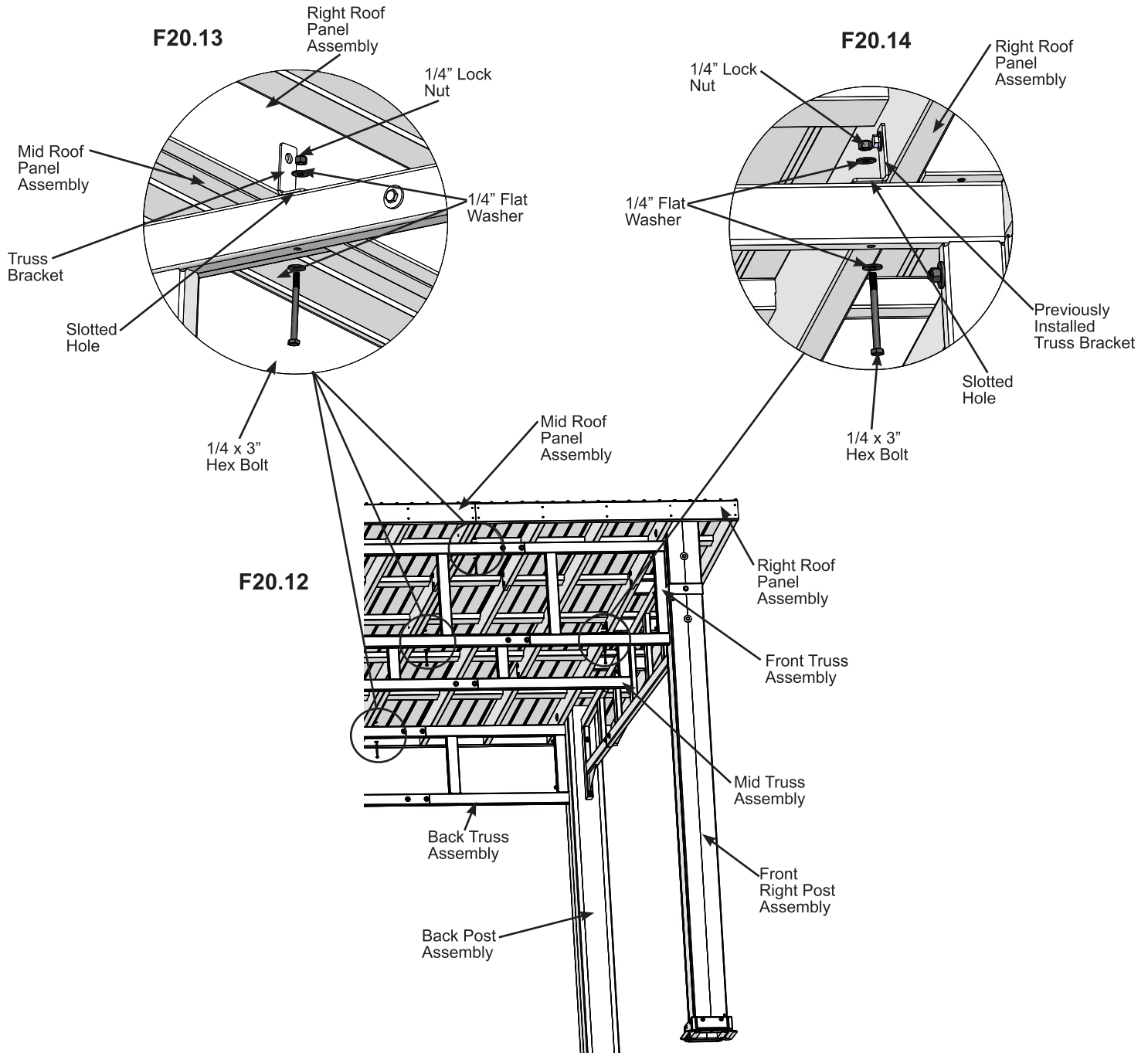

Components

3 x Truss Bracket

Hardware

4 x 1/4 x 3" Hex Bolt
(1/4" flat washer x 2, 1/4" lock nut)

Step 20: Attach Roof Panels

Part 6



K: Connect Right Roof Panel Assembly and Mid Roof Panel Assembly through the Rafters and Truss Brackets using three 5/16 x 3-1/4" Hex Bolt (with 5/16" flat washer, 1/4-5/16" large washer and 5/16" lock nut) (F20.15 and F20.16)

L: Tighten all bolts.

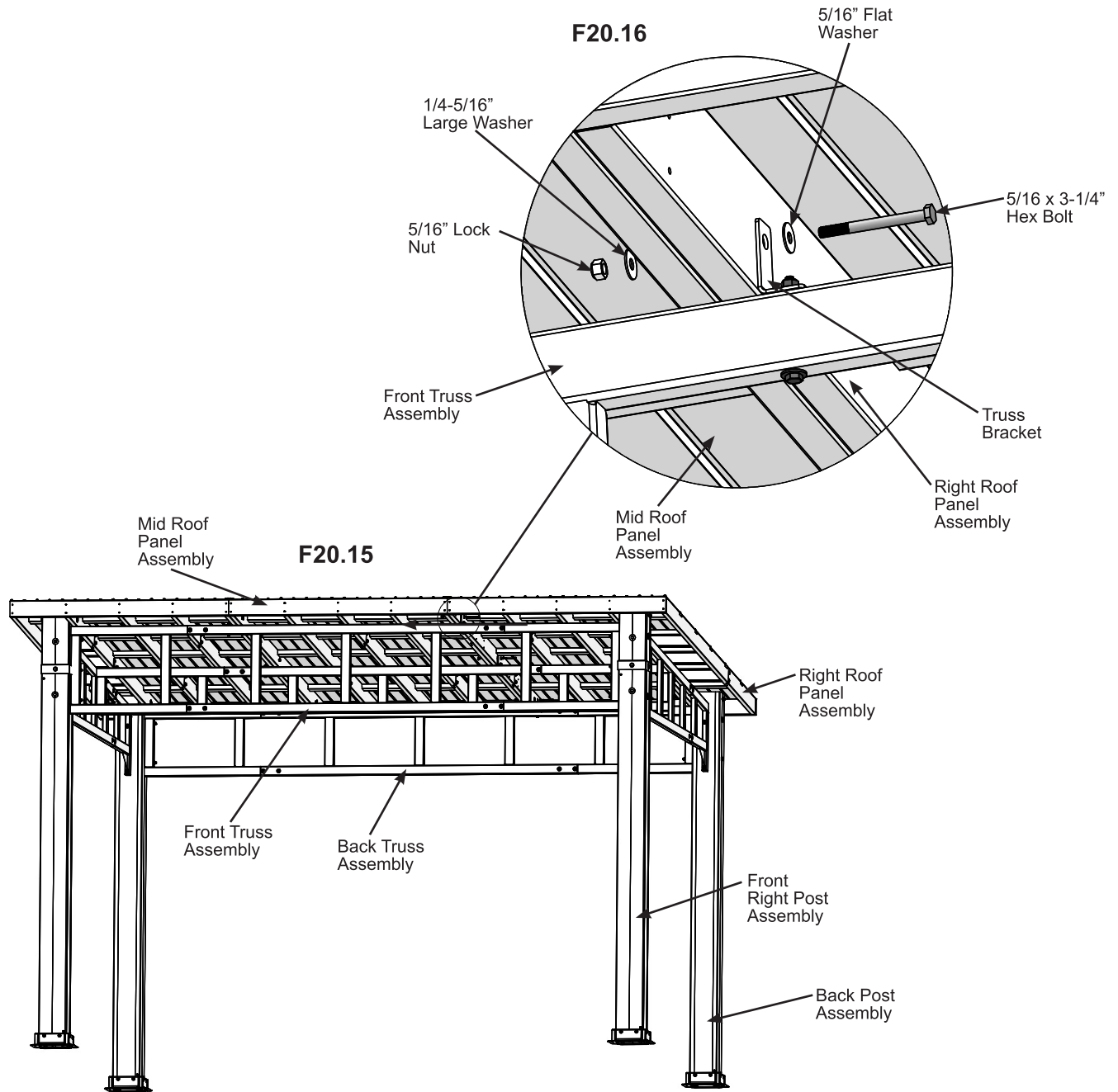

Hardware

3 x 5/16 x 3-1/4" Hex Bolt
(5/16" flat washer, 1/4-5/16" large washer and 5/16 lock nut)

Step 20: Attach Roof Panels

Part 7



M: Connect Left Roof Panel Assembly and Right Roof Panel Assembly to the Mid Roof Panel Assembly through Rafter Assemblies using 24 #8 x 2-1/4" Wood Screws. (F20.17 and F20.18)

F20.17

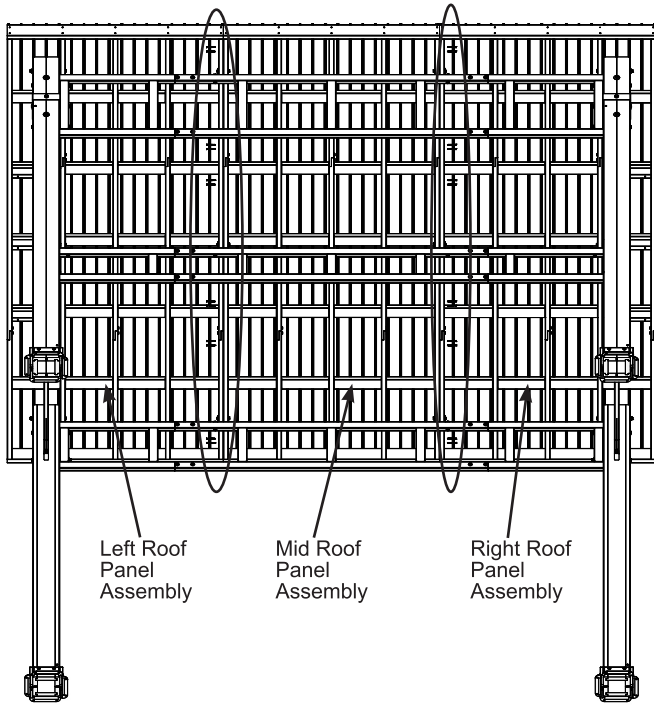

F20.18

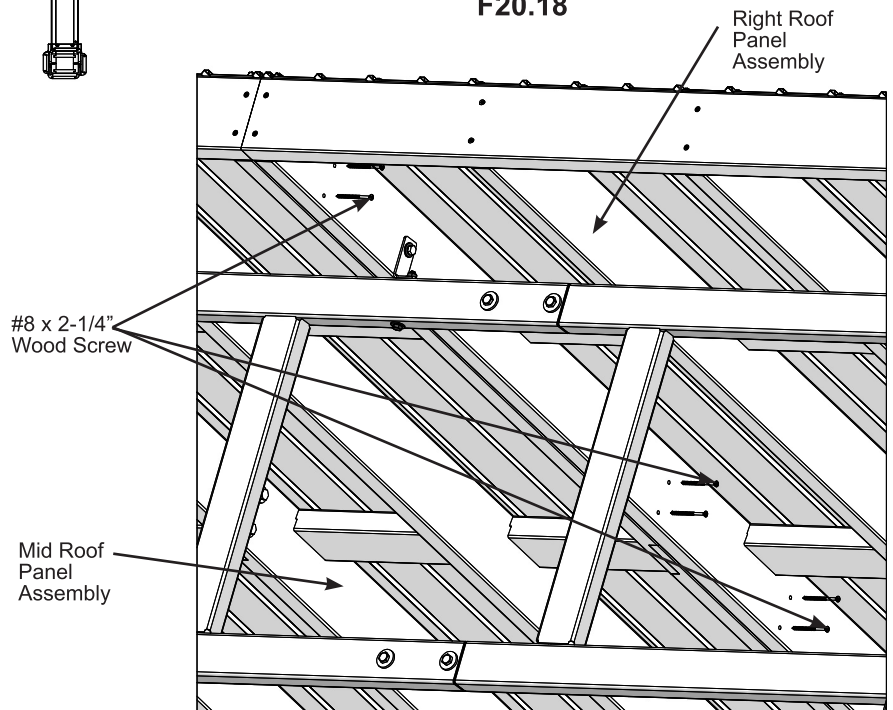

Hardware

24 x #8 x 2-1/4" Wood Screw

Step 21: Roof Cap Assembly



A: Between each Roof Panel Assembly slide one Flat Roof Cap - Top over the Flat Roof Clips, from the bottom up with the cut end leading. (F21.1, F21.2 and F21.3)

B: Slide Flat Roof Cap - Bottom over the Flat Roof Clips, into the Flat Roof Cap - Top and push until the Flat Roof Cap - Top is at the top of the roof. (F21.3, F21.4, F21.5 and F21.6)

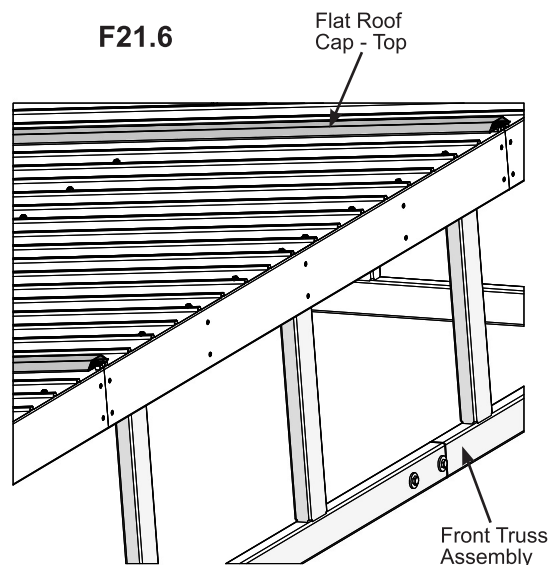
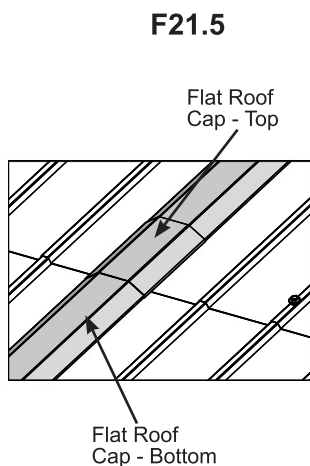
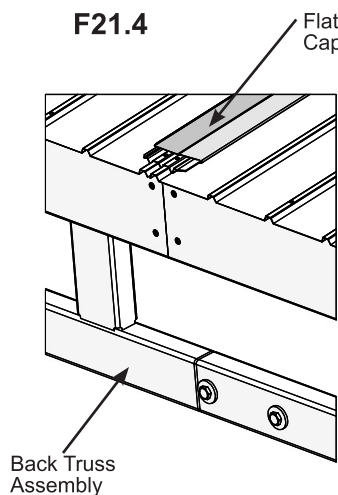
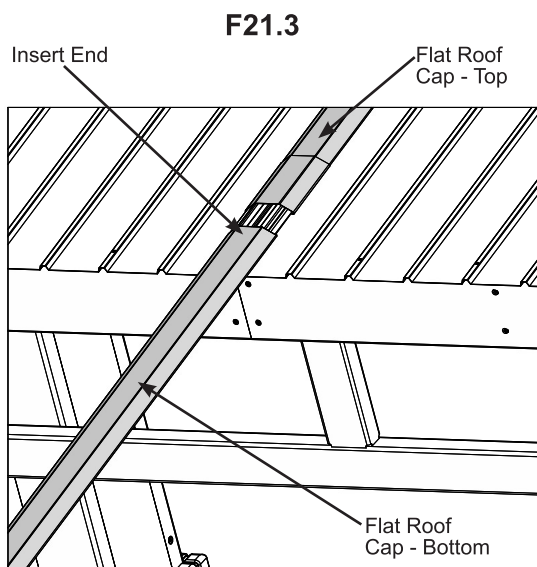
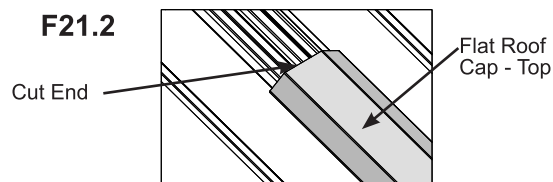
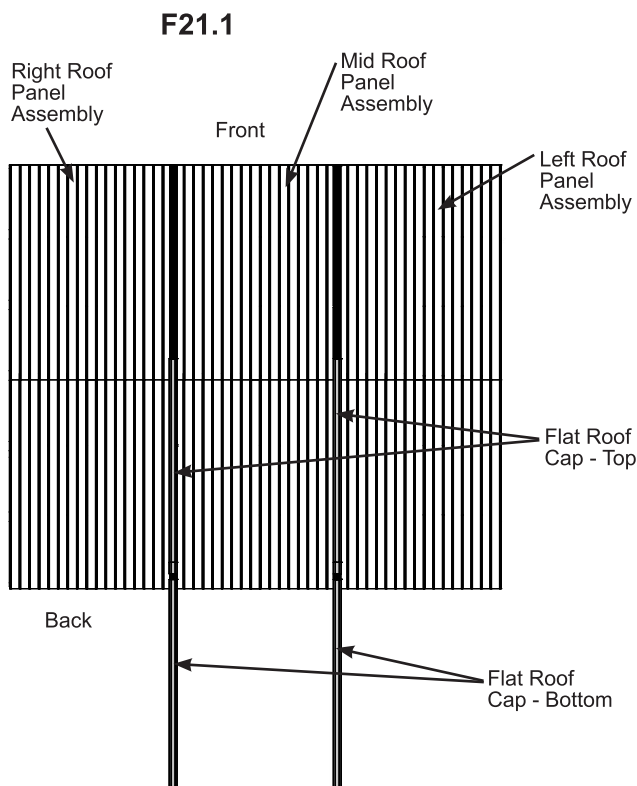

Components

- 2 x Flat Roof Cap - Bottom
- 2 x Flat Roof Cap - Top

Step 22: Back Fascia Cover

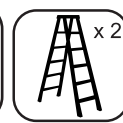

A: Along the back of the Gazebo starting 1-1/8" (28.5mm) from one end install two Flat Roof Back Fascia Covers, under the roofing panels, overlapped in the center. Attach Flat Roof Back Fascia Covers using 12 #8 x 3/4" Sheet Metal Screws. (F22.1, F22.2 and F22.3)

F22.1

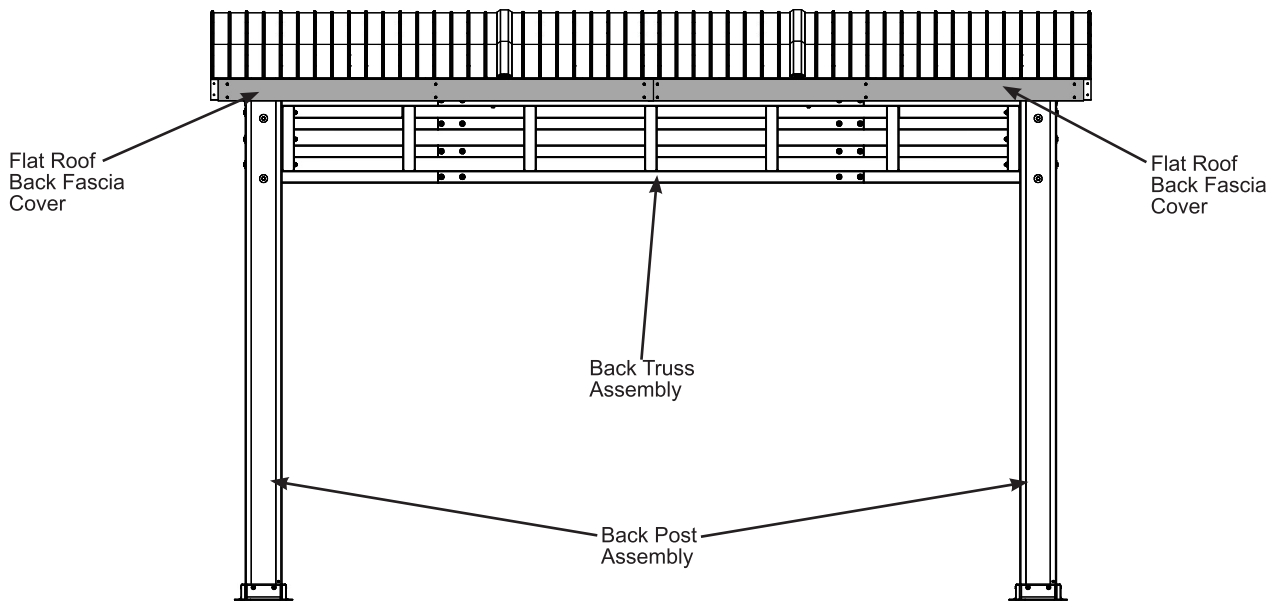

F22.2

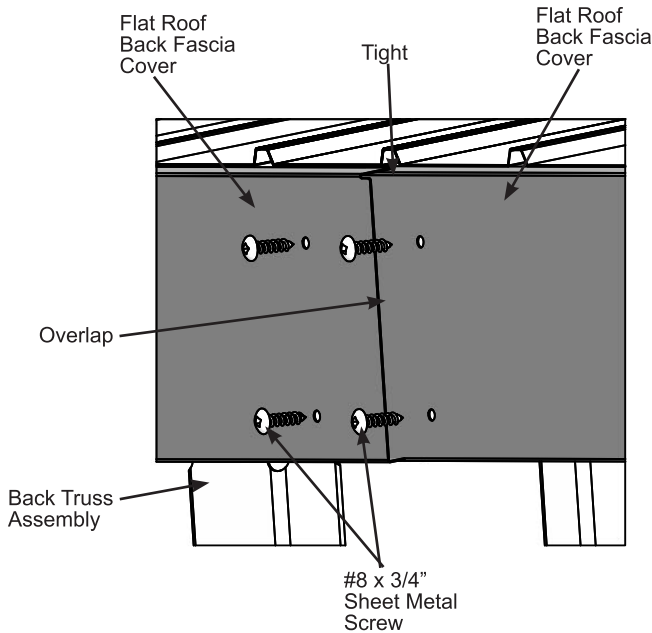

F22.3

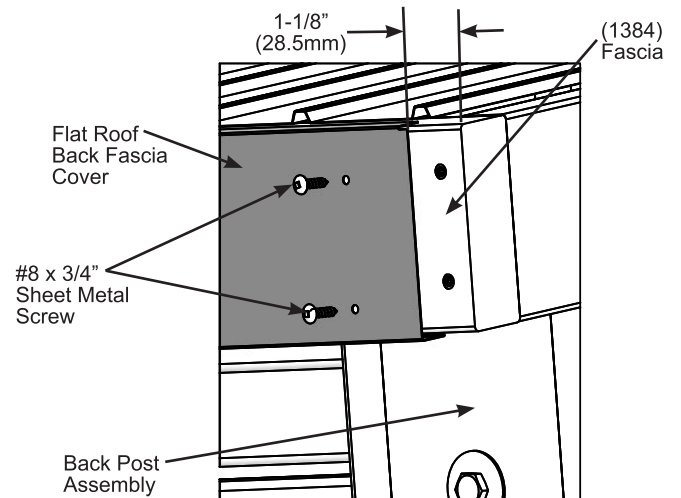

Components

2 x Flat Roof Back Fascia Cover

Hardware

12 x #8 x 3/4" Sheet Metal Screw

Step 23: Back Edges



A: Place one Roof Back Edge - Right and one Roof Back Edge - Left on the bottom of the Roof Panel Assemblies so the ends are tight and align with the holes in the roofing panels. Attach both Roof Back Edges with 30 #8 x 1" Roofing Screws. (F23.1, F23.2 and F23.3)

F23.1

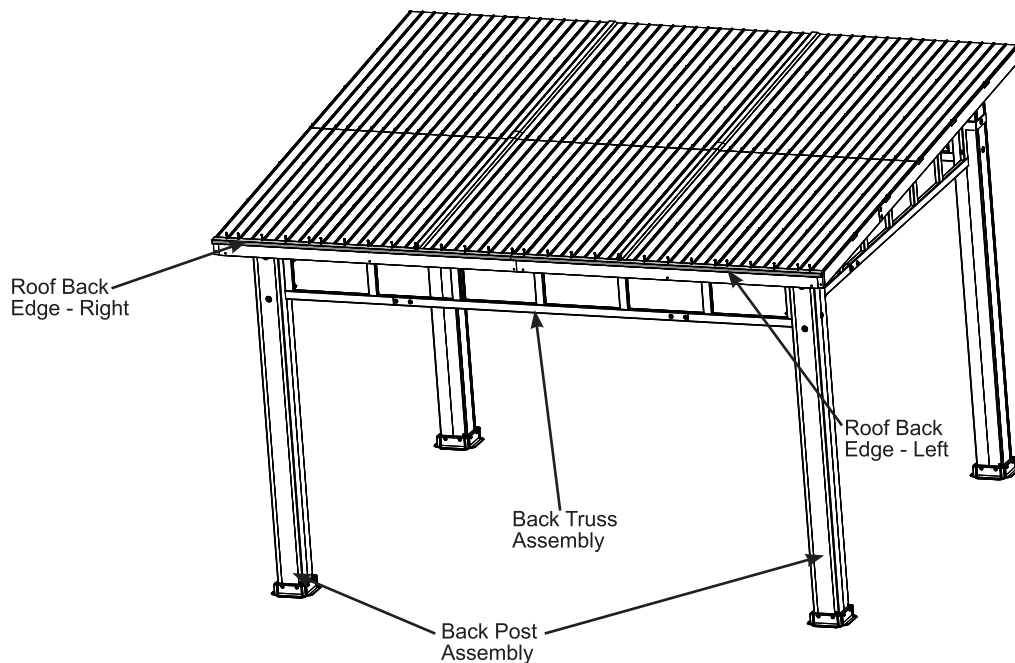

F23.2

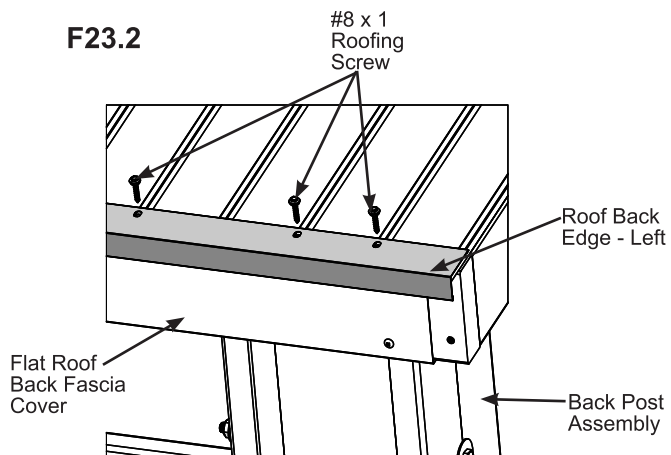

F23.3

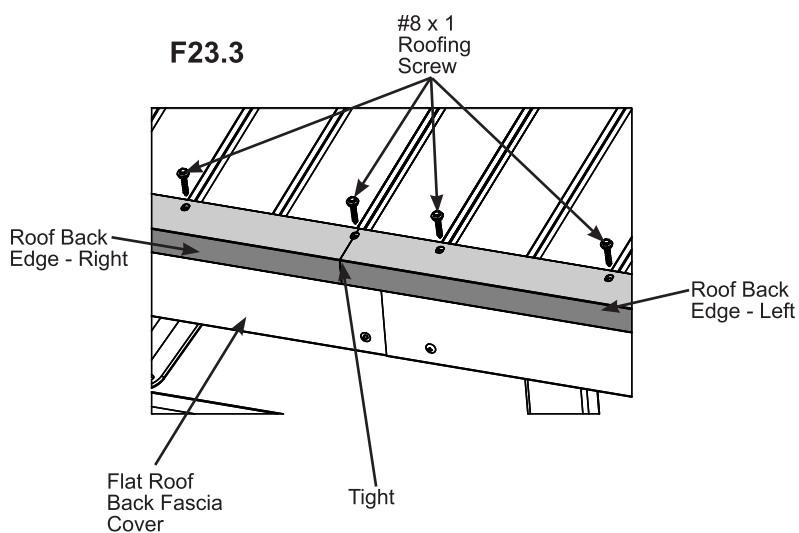

Components

- 1 x Roof Back Edge - Right
- 1 x Roof Back Edge - Left

Hardware

- 30 x #8 x 1" Roofing Screw

Step 24: Side Fascia Cover

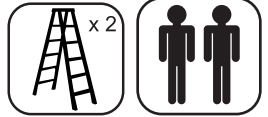

A: Along both sides of the Gazebo install two Flat Roof Side Fascia Covers, overlapped in the center starting flush to the back fascia. Attach Flat Roof Side Fascia Covers using 12 #8 x 3/4" Sheet Metal Screws per side. (F24.1, F24.2, F24.3 and F24.4)

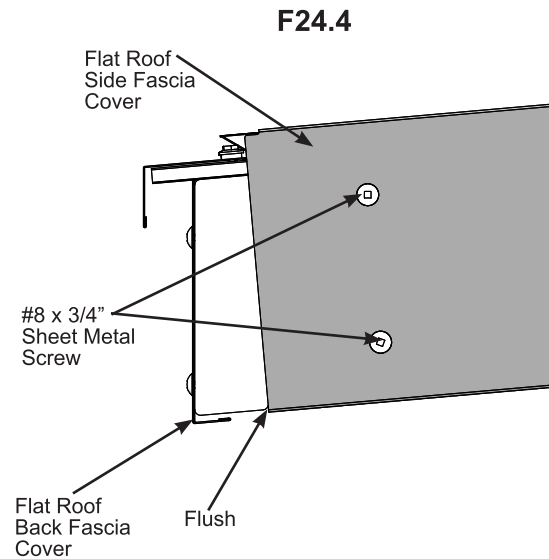
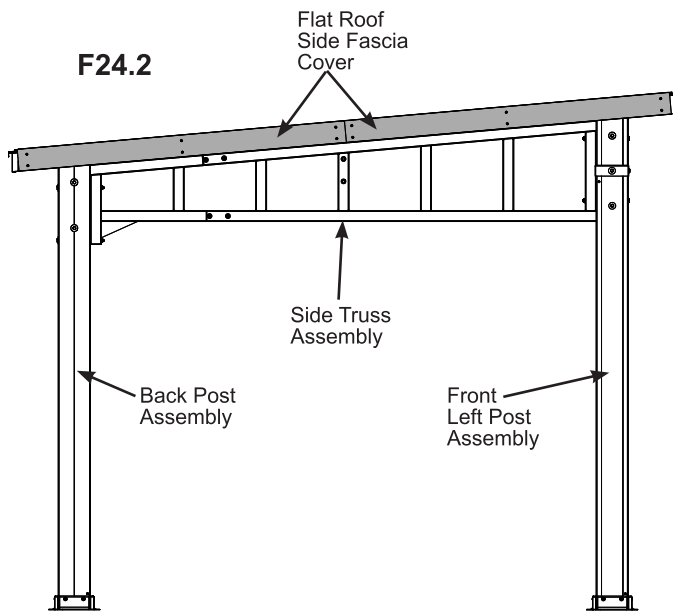
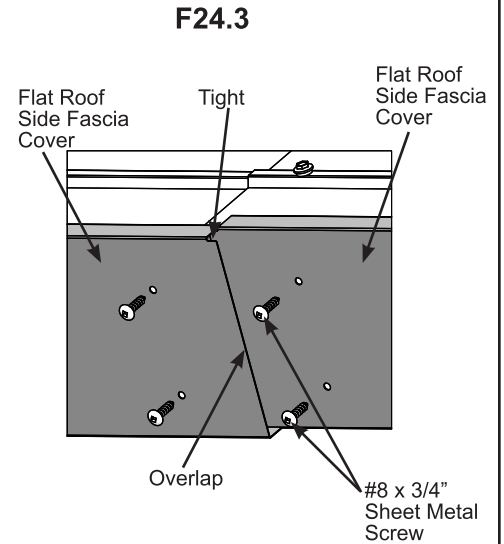
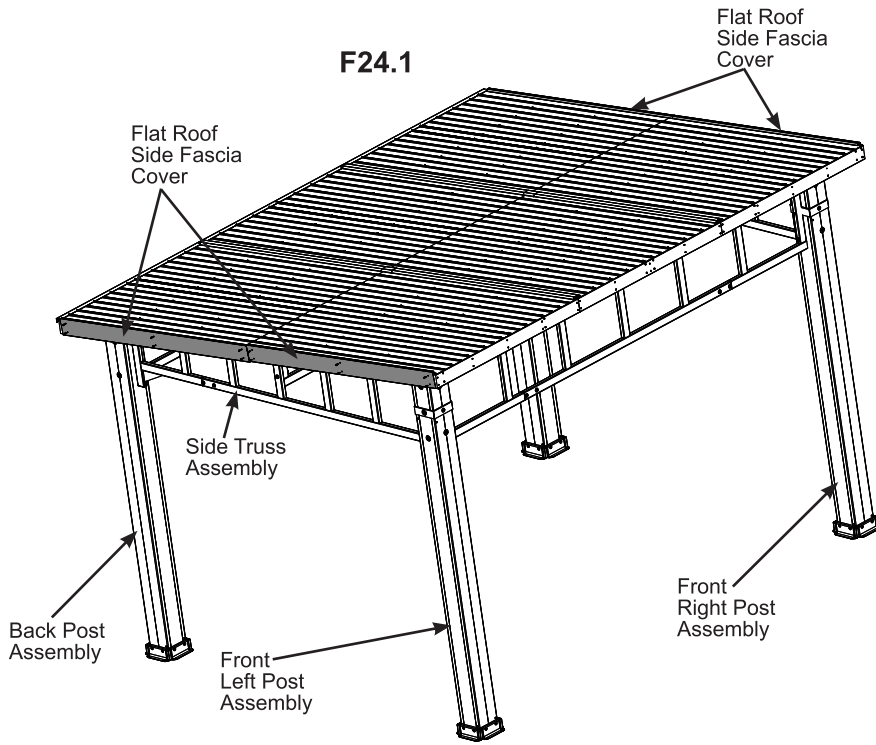

Components

4 x Flat Roof Side Fascia Cover

Hardware

24 x #8 x 3/4" Sheet Metal Screw

Step 25: Front Fascia Cover

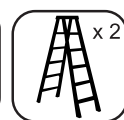

A: Along the front of the Gazebo starting 1-1/8" (28.5mm) from the end install two Flat Roof Front Fascia Covers, overlapped in the center. Attach Flat Roof Front Fascia Covers using 12 #8 x 3/4" Sheet Metal Screws. (F25.1, F25.2, F25.3 and F25.4)

F25.1

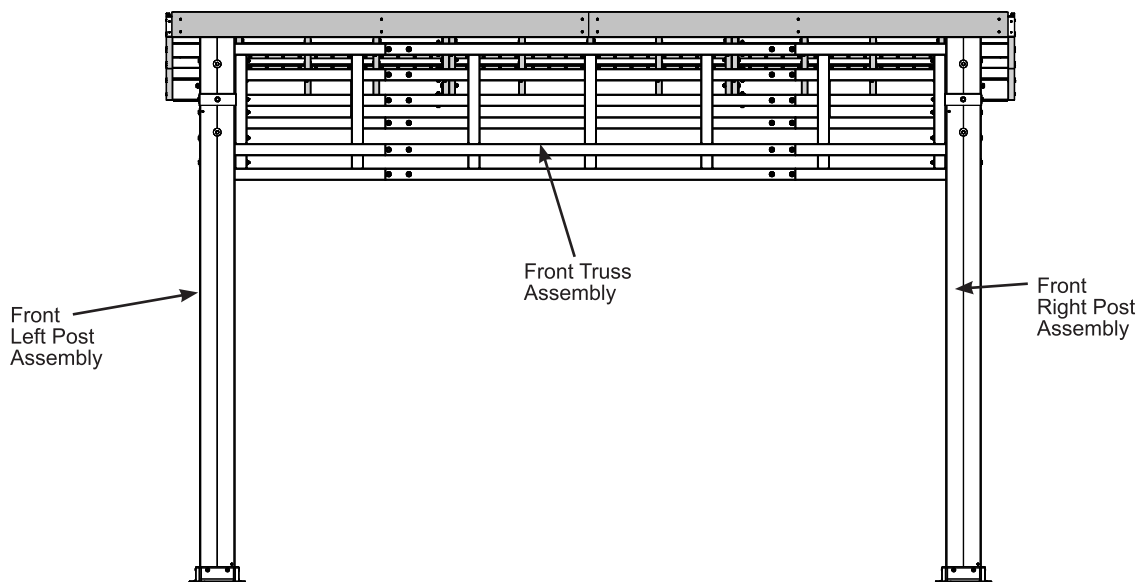

F25.2

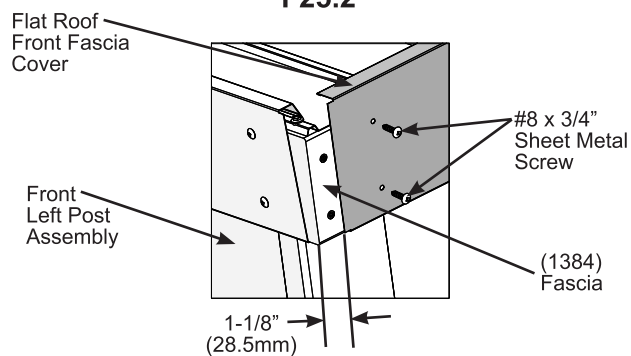

F25.4

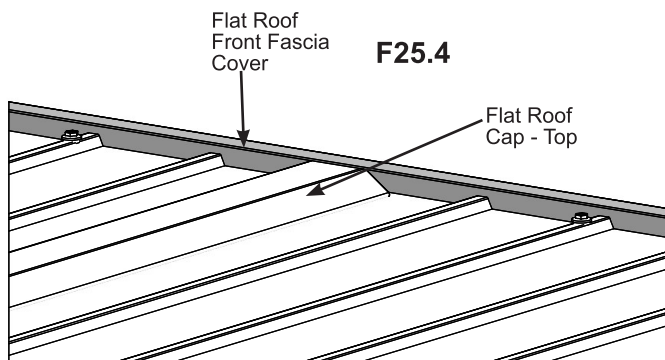

F25.3

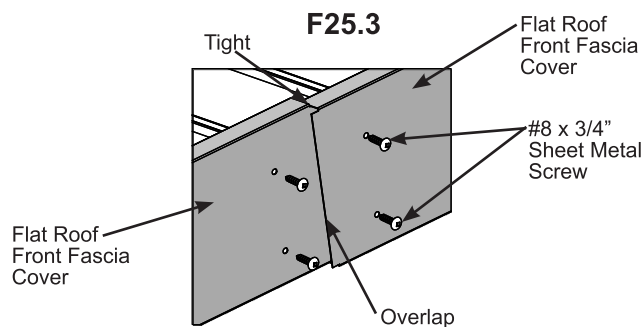

Components

2 x Flat Roof Front Fascia Cover

Hardware

12 x #8 x 3/4" Sheet Metal Screw

Step 26: Attach Corner Caps



A: At the front left corner place one Flat Roof Front Corner Cover - Left tight to the bottom of the fascia and rafter then attach with four #8 x 3/4" Sheet Metal Screws. (F26.1, F26.2 and F26.3)

B: At the front right corner place one Flat Roof Front Corner Cover - Right tight to the bottom of the fascia and rafter then attach with four #8 x 3/4" Sheet Metal Screws. (F26.1, F26.2 and F26.3)

C: At the back left corner place one Flat Roof Back Corner Cover - Left tight to the bottom of the fascia and rafter then attach with four #8 x 3/4" Sheet Metal Screws. (F26.1 and F26.4)

D: At the back right corner place one Flat Roof Back Corner Cover - Right tight to the bottom of the fascia and rafter then attach with four #8 x 3/4" Sheet Metal Screws. (F26.1 and F26.5)

F26.1

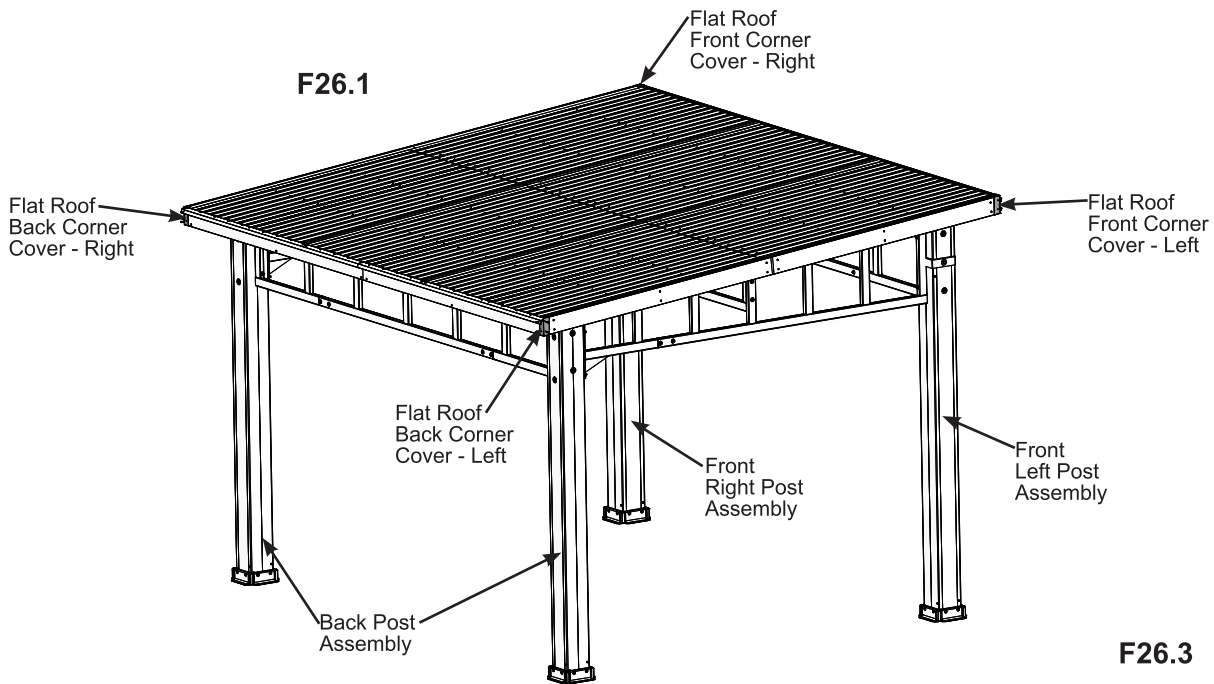

F26.3

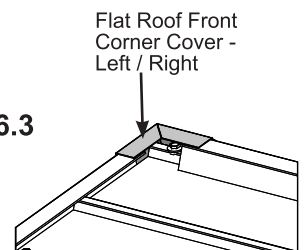

F26.5

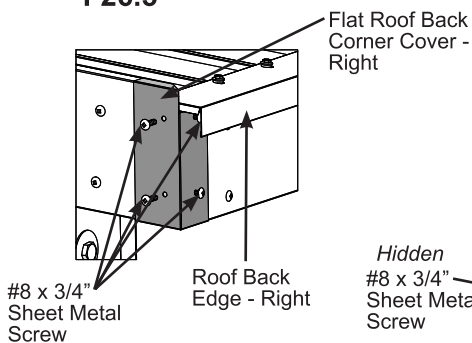

F26.4

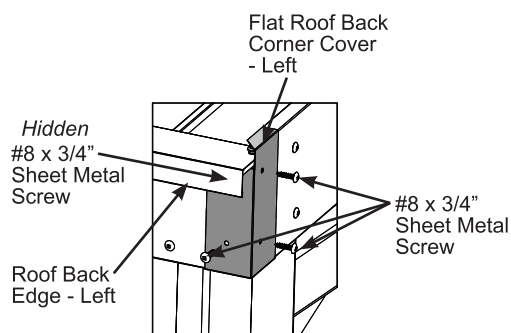

F26.2

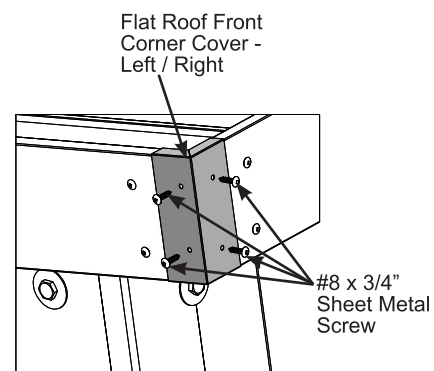

Components

- 1 x Flat Roof Front Corner Cover - Right
- 1 x Flat Roof Front Corner Cover - Left
- 1 x Flat Roof Back Corner Cover - Right
- 1 x Flat Roof Back Corner Cover - Left

Hardware

- 16 x #8 x 3/4" Sheet Metal Screw

Step 27: Attach Roof Caps



A: Secure the Flat Roof Cap - Bottoms to the Roofing Panels using two #8 x 3/4" Sheet Metal Screws per Flat Roof Cap - Bottom. (F27.1 and F27.2)

F27.1

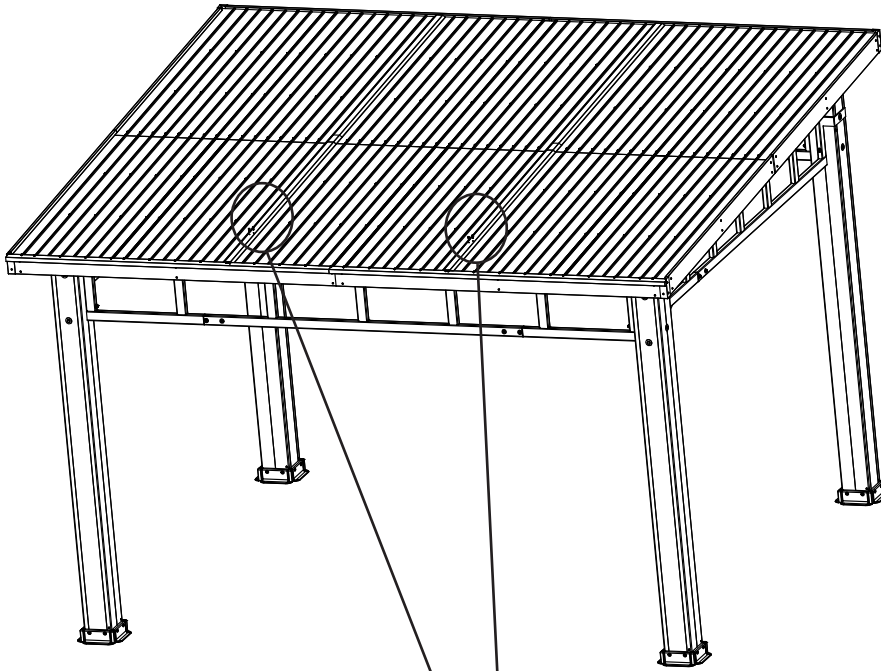

F27.2

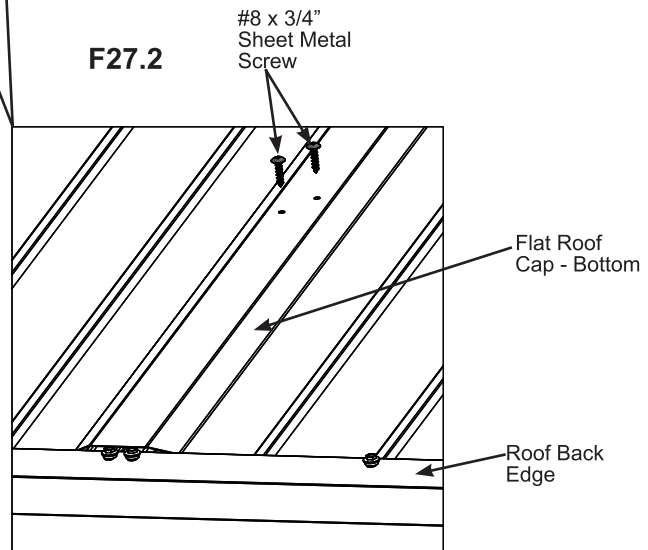

Hardware

4 x #8 x 3/4" Sheet Metal Screw

Step 28: Plaque



A: Attach Gazebo ID Plaque to a prominent location on your gazebo with two #8 x 3/4" Sheet Metal Screws. This provides warnings concerning safety and important contact information. A tracking number is provided to allow you to get critical information or order replacement parts for this specific model. (F28.1 and F28.2)

F28.1

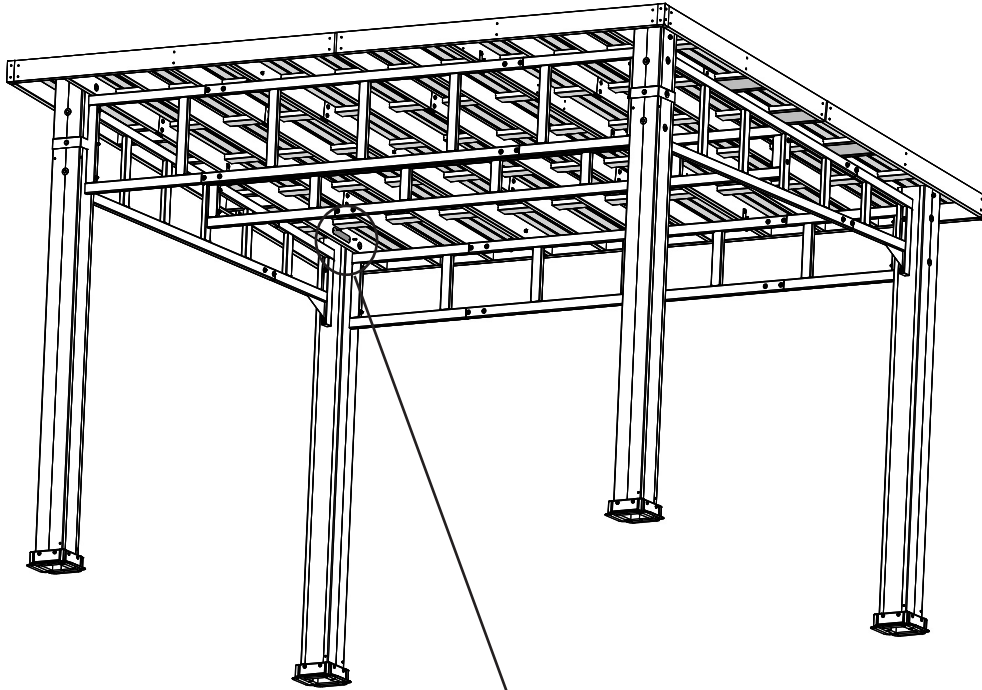

F28.2

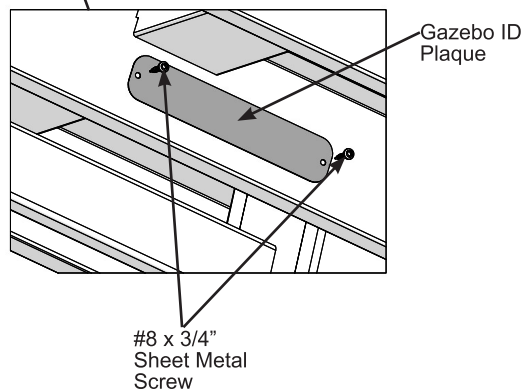

Components

1 x Gazebo ID Plaque

Hardware

2 x #8 x 3/4" Sheet Metal Screw



Yardistry® 375 Sligo Road West, P.O. Box 10, Mount Forest, ON Canada N0G 2L1

Distributed by:
Costco Wholesale Corporation
P.O. Box 34535
Seattle, WA 98124-1535
USA
1-800-774-2678
www.costco.com

Costco Wholesale Canada Ltd.*
415 W. Hunt Club Road
Ottawa, Ontario
K2E 1C5, Canada
1-800-463-3783
www.costco.ca

* faisant affaire au Québec sous
le nom les Entrepôts Costco

Importado por:
Importadora Primex S.A. de C.V.
Blvd. Magnocentro No. 4
San Fernando La Herradura
Huixquilucan, Estado de México
C.P. 52765
RFC: IPR-930907-S70
(55)-5246-5500
www.costco.com.mx

Costco Wholesale Australia Pty Ltd
17-21 Parramatta Road
Lidcombe NSW 2141
Australia
www.costco.com.au

Costco Wholesale UK Ltd /
Costco Online UK Ltd
Hartspring Lane
Watford, Herts
WD25 8JS
United Kingdom
01923 213113
www.costco.co.uk

Costco Wholesale Spain S.L.U.
Polígono Empresarial Los Gavilanes
C/ Agustín de Betancourt, 17
28906 Getafe (Madrid) España
NIF: B86509460
900 111 155
www.costco.es

Costco Wholesale Iceland ehf.
Kauptún 3-7, 210 Gardabaer
Iceland
www.costco.is

Costco France
1 avenue de Bréhat
91140 Villebon-sur-Yvette
France
01 80 45 01 10
www.costco.fr

Costco Wholesale Japan Ltd.
2 Kakuchi, 2 Gaiku, Kaneda-Nishi
361 Urikura, Kisarazu shi
Chiba, 292-0007 Japan
0570-200-800
www.costco.co.jp

Costco Wholesale Korea, Ltd.
40, Iljik-ro
Gwangmyeong-si
Gyeonggi-do, 14347, Korea
1899-9900
www.costco.co.kr

Costco Wholesale New Zealand Limited
2 Gunton Drive
Westgate
Auckland 0814
New Zealand
www.costco.co.nz

Costco (China) Investment Co., Ltd.
Room 1003, Block 2, 2388 Xiupu Road,
Pudong New Area, Shanghai
China 201315
+86-21-6257-7065

Costco Wholesale Sweden AB
Box 614
114 11 Stockholm
Sweden
www.costco.se

AUSTRALIA: Our goods come with guarantees that cannot be excluded under the Australian Consumer Law. You are entitled to a replacement or refund for a major failure and for compensation for any other reasonably foreseeable loss or damage. You are also entitled to have the goods repaired or replaced if the goods fail to be of acceptable quality and the failure does not amount to a major failure.

AUSTRALIE : Nos articles sont offerts avec des garanties qui ne peuvent connaître d'exclusions au regard de la loi australienne sur la protection des consommateurs. Vous avez droit au remplacement ou au remboursement en cas de défaillance majeure de votre article ainsi qu'à une compensation en cas de perte ou de dommage prévisible. Vous avez aussi droit à la réparation ou au remplacement de l'article s'il n'est pas d'une qualité acceptable et que la défaillance n'est pas majeure.

AUSTRALIA: Nuestros productos cuentan con garantías que no se pueden excluir bajo las Leyes del Consumidor de Australia. Usted tiene derecho a un cambio o devolución en caso de un fallo importante ya una compensación por cualquier otra pérdida o daño razonablemente previsible. También tiene derecho a la reparación o reemplazo de los bienes, si éstos no cumplen con una calidad aceptable y el fallo no constituye un fallo importante.



Customer Registration Card - Tarjeta de Registro del Cliente - Carte d'inscription du client

First Name - Primer Nombre - Prénom	Initial - Inicial - Initiale	Last Name - Apellido - Nom de famille

Street - Calle - Rue	PO Box - Casilla postal - Boîte postale	Apt. No. - App.

City - Ciudad - Ville	State/Province - Estado/Provincia - État/Province

ZIP/Postal Code - Código Postal - ZIP/Code postal	Country - País - Pays

E-mail Address - Dirección de E-mail - Adresse courriel	Telephone Number - No. de Teléfono - N° de téléphone

Model Name - Nombre del Modelo - Nom du modèle	Model Number (from front cover) - Número de Modelo (de la portada) - N° du modèle (page de couverture)

Date of Purchase - Fecha de Compra - Date d'achat (mm/dd/yyyy) (mm/dd/aaaa) (mm/jj/aaaa)	Place of Purchase - Comprado a - Lieu d'achat

Comments - Comentarios - Commentaires:

Mail To - Enviar por Correo a - Envoyer par courrier à:

Yardistry
375 Sligo Road West, PO Box 10
Mount Forest, Ontario, Canada, N0G 2L0
Attention: Consumer Relations
Atención a: Servicio de Atención al Cliente
À l'attention de: Service à la clientèle

Online Registration - Registro online - Enregistrement en ligne:

www.yardistrystructures.com/warranty

Hours/ Heures/ Horas: 8:30 am - 5:00 pm EST
(excl. holidays/ hors jours fériés/ excepto los días festivos)

English and French Spoken / Anglais et français parlés / Inglés y francés hablado

Yardistry would like to say "Thank you" for your time and feedback.

Yardistry quiere "Agradecerle" por su tiempo y su opinión.

Yardistry aimerait vous remercier d'avoir pris le temps de répondre au sondage.