

# 12' X 12' WOOD GAZEBO WITH ALUMINUM ROOF

Installation and Operating Instructions – YM12810



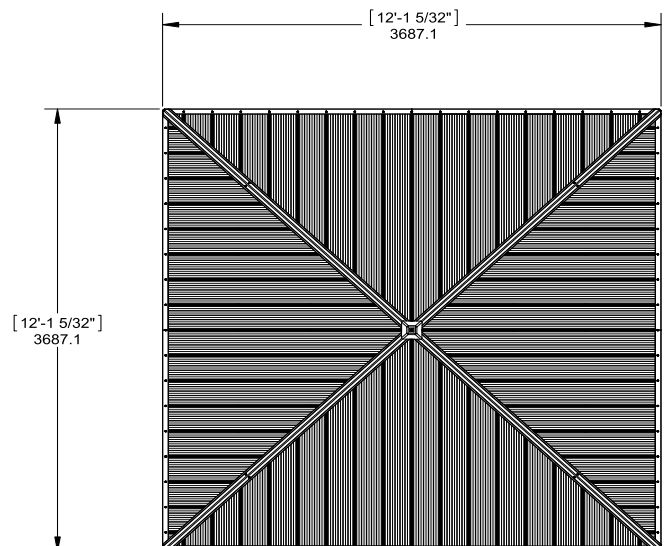
HEIGHT:  
10'6" or 3.2m

Revised 10-25-2017

**YARDISTRY**<sup>®</sup>

Yardistry – North America  
Toll Free Customer Support: 1.888.509.4382  
info@yardistrystructures.com  
www.yardistrystructures.com

Yardistry / Selwood Products – Europe  
Customer Support: +44 1284 852569  
parts@selwoodproducts.com  
www.selwoodproducts.com



## **Important Safety Notice!**

Yardistry components are intended for privacy, decorative and ornamental use only.

### **Product is NOT INTENDED for the following:**

- A safety barrier to prevent unsupervised access to pools, hot tubs, spas or ponds.
- As load bearing support for a building, structure, heavy objects or swings.
- Used in structures that trap wind, rain or snow that would create extra load on the product.

### **Accumulated snow must be removed from roof.**

**DO NOT** climb or walk on roof for any reason.

**Permanent structures may require a building permit.** As the purchaser and or installer of this product you are advised to consult local planning, zoning and building inspection departments for guidance on applicable building codes and/or zoning requirements.

**Wood is NOT flame retardant and will burn.** Grills, fire pits and chimineas are a fire hazard if placed too close to a Yardistry structure. Consult user's manual of the grill, fire pit or chimenea for safe distances from combustible materials.

**Wear gloves to avoid injury** from possible sharp edges of individual elements before assembly.

**During installation, follow all safety warnings provided with your tools and use OSHA approved safety glasses.** Some structures may require two or more people to install safely.

**Check for underground utilities before digging or driving stakes into the ground!**

**It is important during assembly to closely follow the instructions,** complete the assembly on a solid level surface and that you follow the instruction to square up, level and anchor the structure, this will reduce the gap at wood connections during assembly.

## **General Information**

**General Information:** Wood components are manufactured with Cedar (C. Lanceolata) which is protected with factory applied water-based stain. Knots, small checks (cracks) and weathering are naturally occurring and do not affect the strength of the product. Annual application of a water-based water repellent sealant or stain is important and will help reduce weathering and checks.

[www.yardistrystructures.com](http://www.yardistrystructures.com)

Questions?

Call toll free or write us at:

1 (888) 509-4382

[info@yardistrystructures.com](mailto:info@yardistrystructures.com)

Patents Pending

# Limited Warranty

Yardistry warrants that this product is free from defect in materials and workmanship for a period of one year from the original date of purchase. In addition, all lumber is warranted for 5 years against rot and decay. This warranty applies to the original owner and registrant and is non-transferable.

Regular maintenance is required to assure the integrity of your product and is a requirement of the warranty. This warranty does not cover any inspection cost.

## **This Limited Warranty does not cover:**

- Labor for replacement of any defective item(s);
- Incidental or consequential damages;
- Cosmetic defects which do not affect performance or integrity;
- Vandalism; improper use or installation; acts of nature;
- Acts of nature including but not limited to wind, storms, hail, floods, excessive water exposure;
- Minor twisting, warping, checking, or any other natural occurring properties of wood that do not affect performance or integrity.

Yardistry products have been designed for safety and quality. Any modifications made to the original product could damage the structural integrity of the product leading to failure and possible injury. Yardistry cannot assume any responsibility for modified products. Furthermore, modification voids any and all warranties.

**This product is warranted for RESIDENTIAL USE ONLY. Yardistry disclaims all other representations and warranties of any kind, express or implied.**

*This Warranty gives you specific legal rights. You may have other rights as well which vary from state to state or province to province. This warranty excludes all consequential damages, however, some states do not allow the limitation or exclusion of consequential damages, and therefore this limitation may not apply to you.*

# Instructions for Proper Maintenance

Your Yardistry structure is designed and constructed of quality materials. As with all outdoor products it will weather and wear. To maximize the enjoyment, safety and life of your structure it is important that you, the owner, properly maintain it.

## HARDWARE:

- Check metal parts for rust. If found, sand and repaint using a non-lead paint complying with 16 CFR 1303.
- Inspect and tighten all hardware after completion of assembly; after first month of use; and then annually. Do not over-tighten as to cause crushing and splintering of wood.
- Check for sharp edges or protruding screw threads, add washers if required.

## WOOD PARTS:

- Applying a water repellent or stain (water-based) on a yearly basis is important maintenance to maintain maximum life and performance of the product.
- Check all wood members for deterioration, structural damage and splintering. Sand down splinters and replace deteriorated wood members. As with all wood, some checking and small cracks in grain is normal
- Some gapping may occur at some wood connections.

## Assembly Guides

### Tools Required:

- |                                  |                  |                           |
|----------------------------------|------------------|---------------------------|
| • Tape Measure                   | • 8' Step Ladder | • 6' Step Ladder x 2      |
| • Carpenters Level               | • Safety Glasses | • Square                  |
| • Standard or Cordless Drill     | • Adult Helper   | • Ratchet                 |
| • #2 Phillips Bit or Screwdriver | • Safety Gloves  | • 7/16, 1/2 & 9/16 Socket |
| • 7/16" & 9/16" Wrench           | • Hard Hat       |                           |

### Symbols:

Throughout these instructions symbols are provided in the top, right-hand corner of the page.



- Use Help, where this is shown, 2, 3 or 4 people are required to safely complete this step. To avoid injury or damage to the assembly make sure to get some help.



- Use a measuring tape to assure proper location



- Pre-drill a pilot hole before fastening screw or lag to prevent splitting of wood.

**If you dispose of your Yardistry structure:** Please disassemble and dispose of your unit so that it does not create any unreasonable hazards at the time it is discarded. Be sure to follow your local waste ordinances.



## Assembly Tips

Following are some helpful tips to make the assembly process smooth and efficient.

### PRE-ASSEMBLIES:

(i.e. Post and Beam Assemblies, Roof Rafter Assembly, etc)

- Work on a raised, solid and flat surface such as, a table or saw horse.
- Keep all connections flush where shown in the instructions.
- When assembling the beams keep parts flat, straight and snug when connecting.

### METAL PARTS:

- Roofing material may have sharp edges, wear safety gloves.
- Remove all plastic covering, on both sides of the metal panels, directly before installing each piece.
- Place roofing material on a non-abrasive surface before and after assembly as it can bend, dent and scratch easily.
- The roofing screws can easily crush the roof panels and roof edges when using a power drill. We recommend hand tightening the roofing screws so they sit snug and tight to the roofing material.

# Permanent Installation Examples

**Note: It is critically important you start with square, solid and level footings, concrete pad or deck to attach your Pergola Room.**

We supply Post Mounts with this structure which gives you the flexibility to permanently install your structure to a pre-existing or new wood or concrete surface.

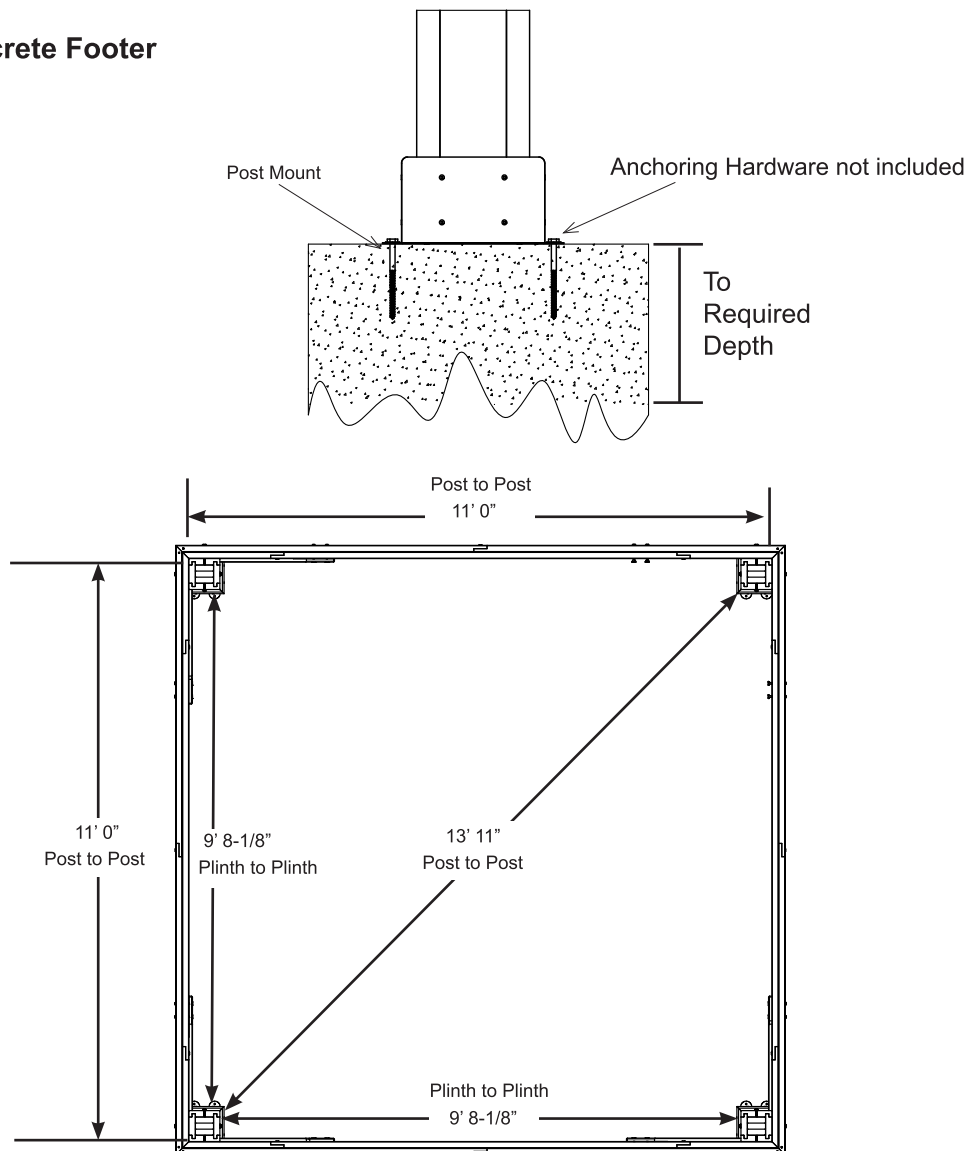
- The hardware to attach the Post Mount to the structure is included.
- The hardware to mount the structure permanently will need to be purchased separately at your local hardware store.

If you are mounting to concrete footers see below for the correct locations and placement. Please double check for possibility of any underground utilities such as gas, telephone, cable or sprinkler lines.

Following are some examples of how to mount the structure to wood or concrete surfaces.

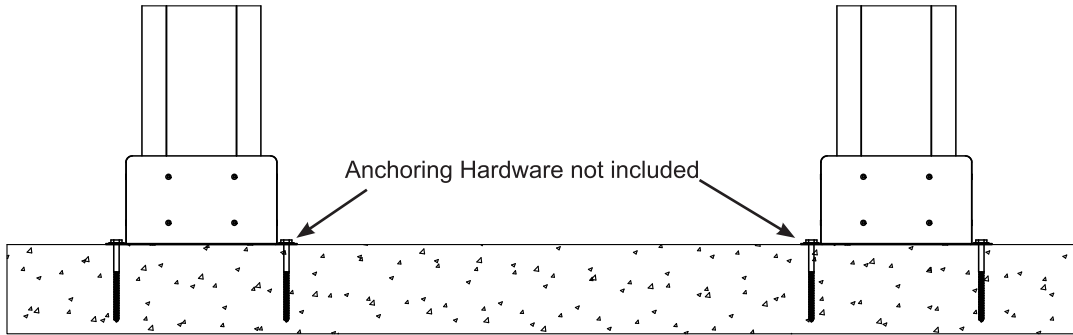
Refer to your local building and city codes, ordinances, neighbourhood covenants, or height restrictions regarding this type of structure for guidance on acceptable installation requirements.

## Concrete Footer

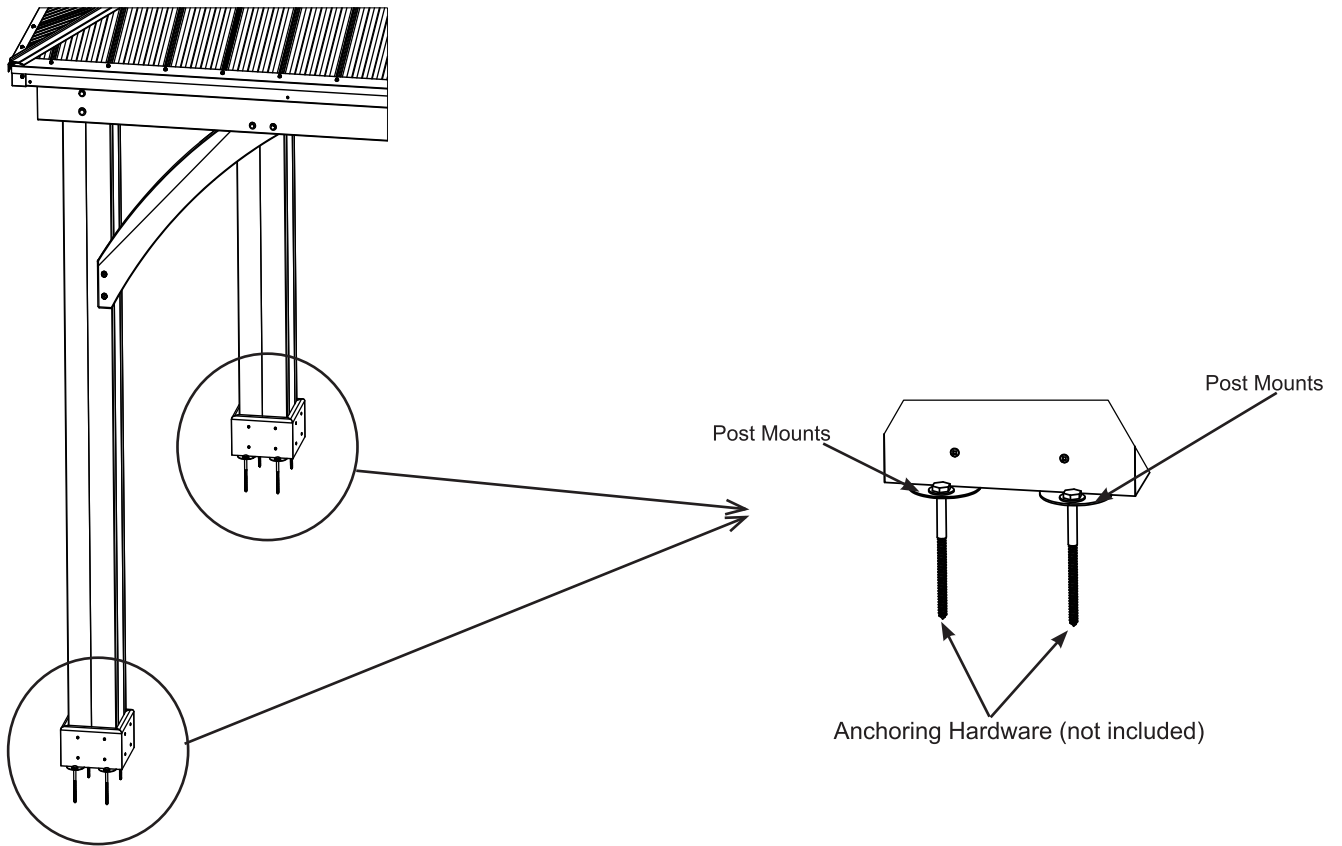
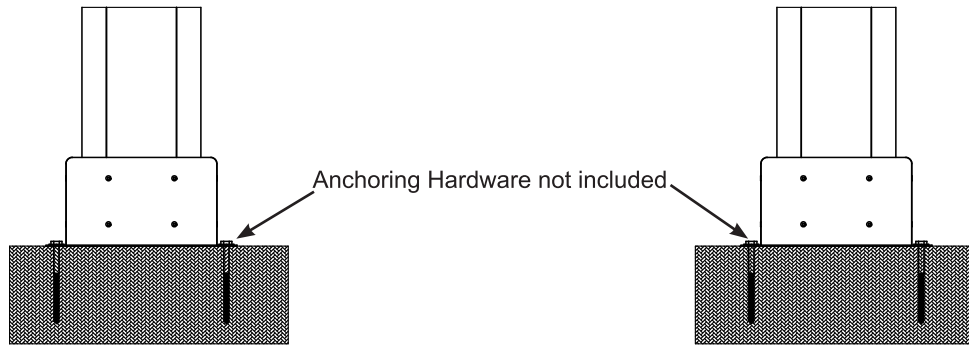


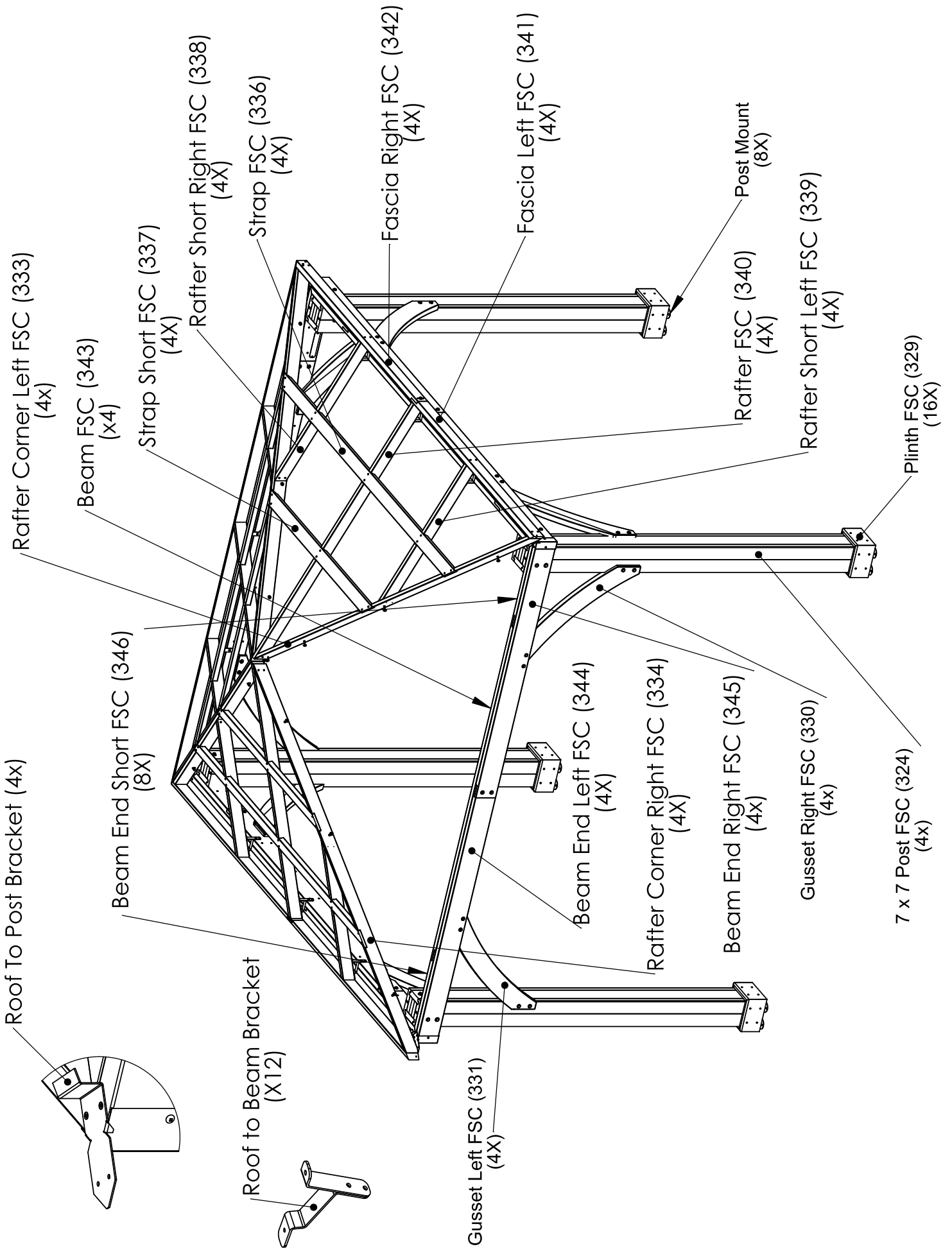
# Permanent Installation Examples cont.

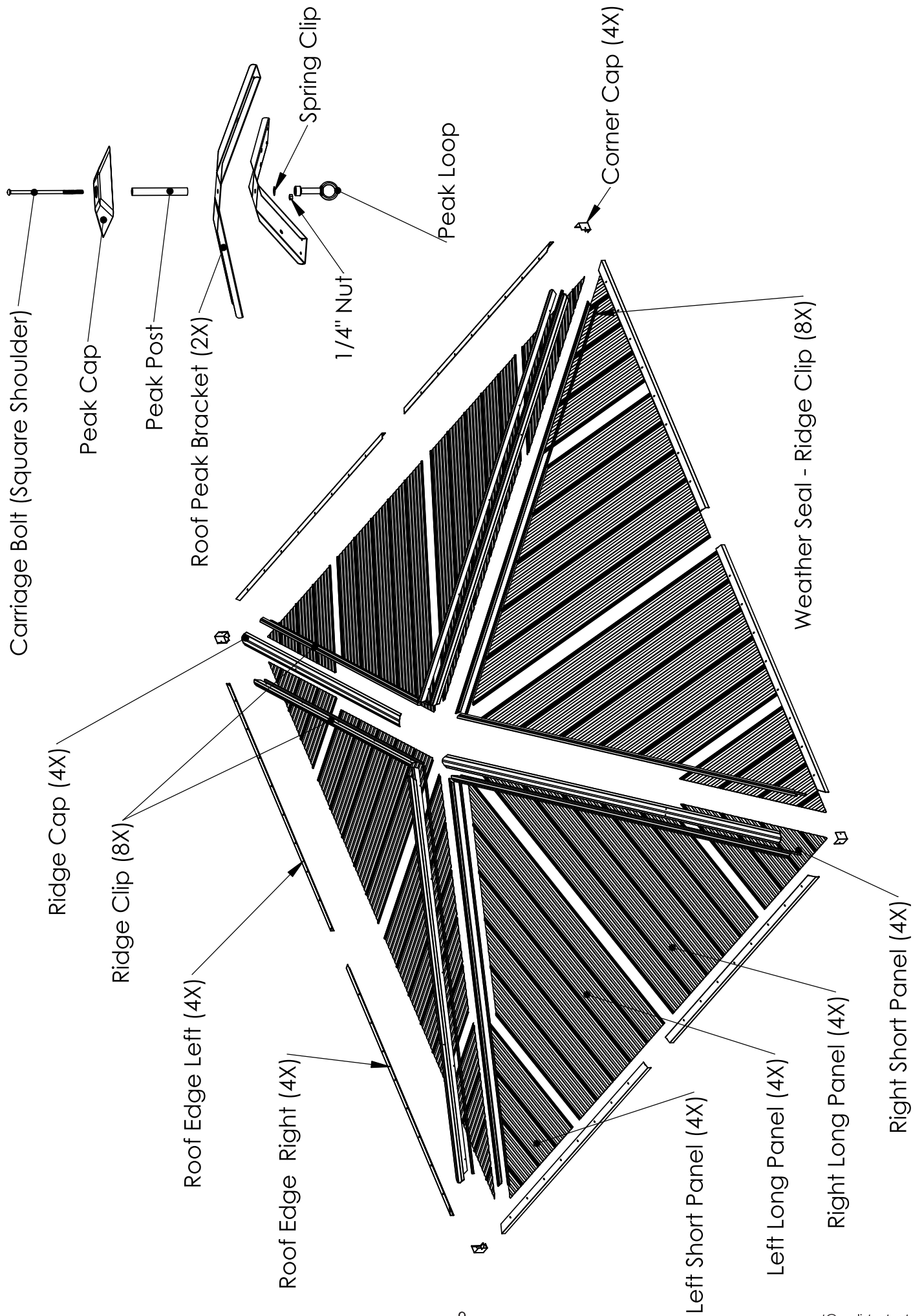
Concrete Patio (min. 11' 6" x 11' 6") with 6" clearance on all sides



Wood Deck (min. 11' 6" x 11' 6") with 6" clearance on all sides







# Part Identification ( Dimensions are approximate and are shown to assist in the identification of parts for assembly. Actual dimensions may be smaller or larger. )

177.8 x 177.8 x 2387.6mm (7 x 7 x 94")

**4pc. (324) - 7 x 7 Post FSC**

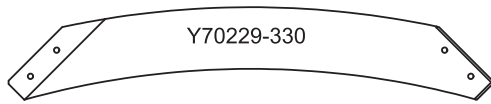


Y70229-324

(1-1/2 x 7-1/2 x 39-1/2")

38.1 x 190.5 x 1003.3mm

**4pc. (330) - Gusset Right FSC**

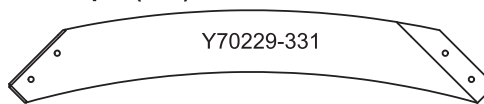


Y70229-330

(1-1/2 x 7-1/2 x 39-1/2")

38.1 x 190.5 x 1003.3mm

**4pc. (331) - Gusset Left FSC**

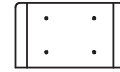


Y70229-331

(5/4 x 6 x 8-7/8")

23.8 x 133.4 x 225.4mm

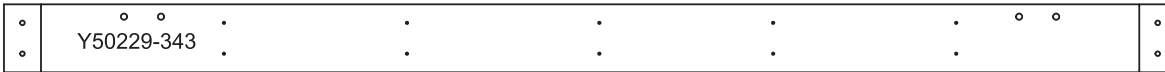
**16pc. (329) - Plinth FSC**



Y50229-329

38.1 x 139.7 x 2413mm (1-1/2 x 5-1/2 x 95")

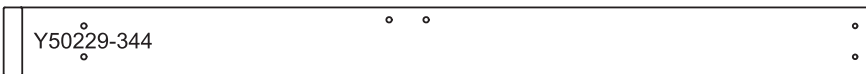
**4pc. (343) - Beam FSC**



Y50229-343

38.1 x 139.7 x 1790.7mm (1-1/2 x 5-1/2 x 70-1/2")

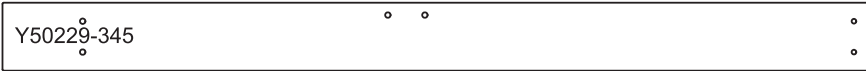
**4pc. (344) - Beam End Left FSC**



Y50229-344

38.1 x 139.7 x 1790.7mm (1-1/2 x 5-1/2 x 70-1/2")

**4pc. (345) - Beam End Right FSC**

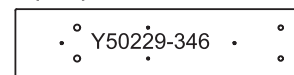


Y50229-345

(1-1/2 x 5-1/2 x 23")

38.1 x 139.7 x 584.2mm

**8pc. (346) - Beam End Short FSC**



Y50229-346

## NOTE:

**Parts have been packed inside (324) 7 x 7 Post. Check for parts inside the posts.**

31.8 x 82.6 x 1866.9mm (1-1/4 x 3-1/4 x 73-1/2")

**4pc. (341) - Fascia Left FSC**



Y50229-341

31.8 x 82.6 x 1866.9mm (1-1/4 x 3-1/4 x 73-1/2")

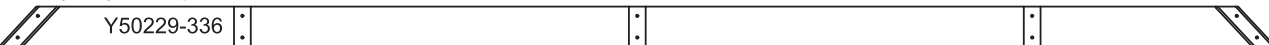
**4pc. (342) - Fascia Right FSC**



Y50229-342

31.8 x 82.6 x 2628.1mm (1-1/4 x 3-1/4 x 103-7/16")

**4pc. (336) - Strap FSC**



Y50229-336

31.8 x 82.6 x 1561.3mm (1-1/4 x 3-1/4 x 61-7/16")

**4pc. (337) - Strap Short FSC**



Y50229-337

31.8 x 76.2 x 1937.1mm (1-1/4 x 3 x 76-1/4")

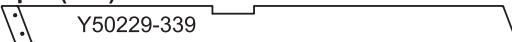
**4pc. (340) - Rafter FSC**



Y50229-340

31.8 x 76.2 x 1062mm (1-1/4 x 3 x 41-13/16")

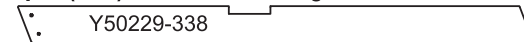
**4pc. (339) - Rafter Short Left FSC**



Y50229-339

31.8 x 76.2 x 1062mm (1-1/4 x 3 x 41-13/16")

**4pc. (338) - Rafter Short Right FSC**



Y50229-338

25.4 x 88.9 x 2631.5mm (1 x 3-1/2 x 103-13/16")

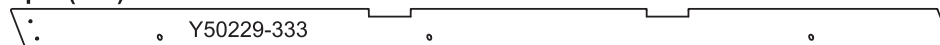
**4pc. (334) - Rafter Corner Right FSC**



Y50229-334

25.4 x 88.9 x 2631.5mm (1 x 3-1/2 x 103-13/16")

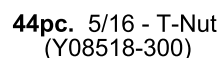
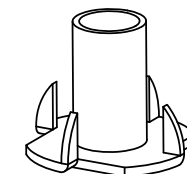
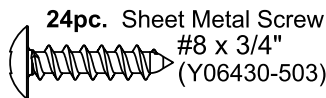
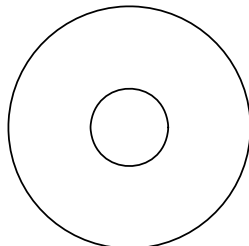
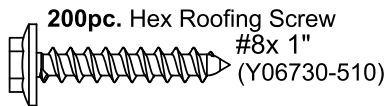
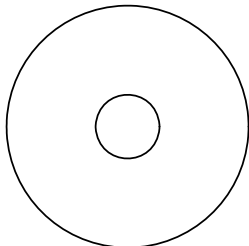
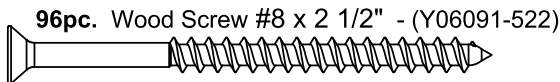
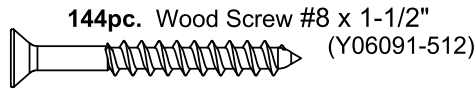
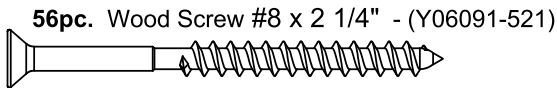
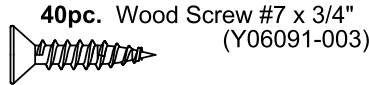
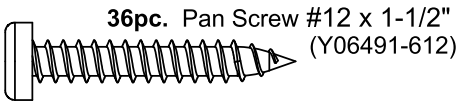
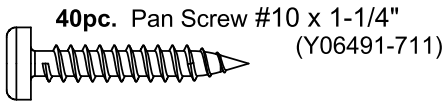
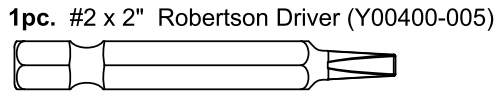
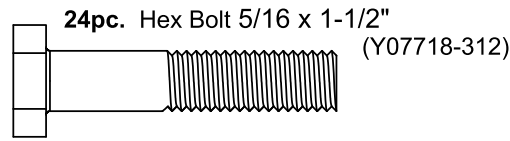
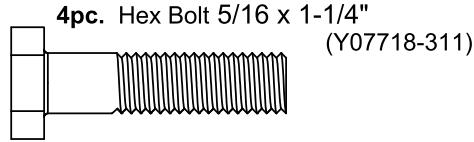
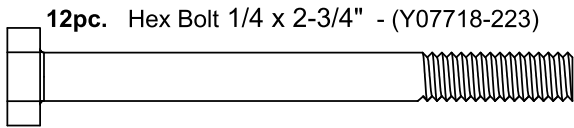
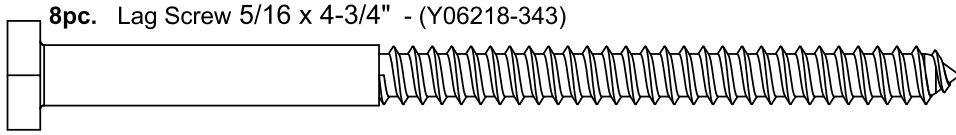
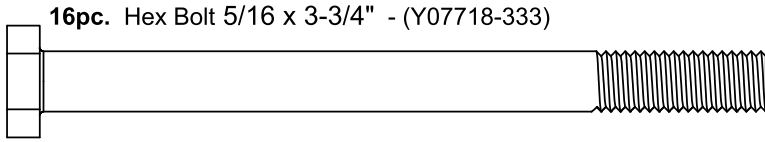
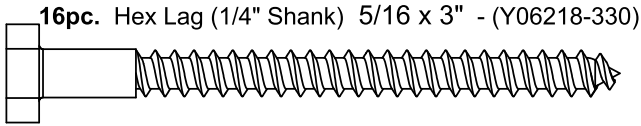
**4pc. (333) - Rafter Corner Left FSC**



Y50229-333



# Hardware Identification ( Dimensions are approximate and are shown to assist in the identification of parts for assembly. Actual dimensions may be smaller or larger. )



# Hardware Identification ( Dimensions are approximate and are shown to assist in the identification of parts for assembly. Actual dimensions may be smaller or larger. )

**4pc. - Left Short Panel**  
(Y01030-099)

**4pc. - Left Long Panel**  
(Y01030-097)

**4pc. - Right Long Panel**  
(Y01030-098)

**4pc. - Right Short Panel**  
(Y01030-100)

**4pc. - Roof Edge Left**  
(Y01030-091)

**4pc. - Ridge Cap**  
(Y01030-093)

**8pc. - Ridge Clip**  
(Y01030-090)

**4pc. - Roof Edge Right**  
(Y01030-092)

**1pc. - Peak Cap**  
(Y01030-095)

**1pc. - Peak Post**  
(Y01000-094)

**1pc. - Roof Set**  
(Y70830-084)

**1pc. - Weather Seal - Ridge Clip (8Pk)**  
(Y70818-074)

**1pc. - Gazebo ID Plaque**  
(Y70800-104)

**1pc. - Post Mount Set (8Pk)**  
(Y70819-057)

**2pc. - 50mm Hook**  
(Y00418-050)

**1pc. - Corner Cap Set (4Pk)**  
(Y70830-103)

**1pc. - Roof To Beam Bracket Set (12Pk)**  
(Y70829-151)

**1pc. - Roof To Post Bracket Set (4Pk)**  
(Y70829-070)

**2pc. - Roof Peak Bracket**  
(Y00430-068)

**1pc. - Carriage Bolt**  
(Y07490-260)

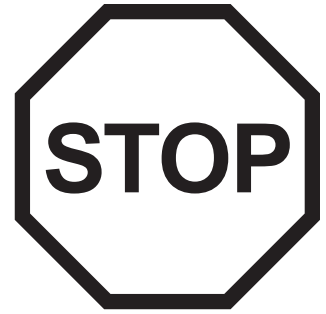
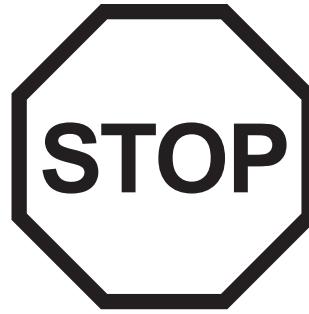
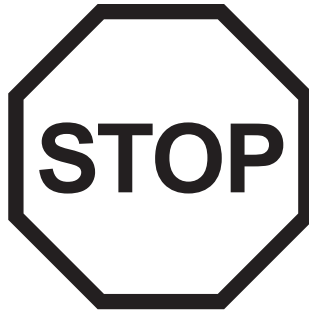
**1pc. - 1/4" Nut**  
(Y08490-200)

**1pc. - Spring Clip**  
(Y09490-001)

**1pc. - Peak Loop**  
(Y20018-003)

**1pc. - Roof Peak Set**  
(Y70830-068)

# Step 1: Inventory Parts - Read This Before Starting Assembly



- A.** This is the time for you to inventory all your hardware, wood and accessories, referencing the parts identification sheets. This will assist you with your assembly.
- Each step indicates which bolts and/or screws you will need for assembly, as well as any flat washers, lock washers, t-nuts or lock nuts.
- B.** If there are any missing or damaged pieces or you need assistance with assembly please contact the consumer relations department directly. Call us before going back to the store.

**1-888-509-4382**  
**support@yardistrystructures.com**

- C.** Read the assembly manual completely, paying special attention to ANSI warnings; notes; and safety/maintenance information on pages 1 - 4.
- Follow the instructions in order.
  - This structure is designed to be assembled and installed ideally by four people, DO NOT attempt to install alone.
  - Consider the slope of elevation where you plan to install the structure. Also, check for gas, telephone, other utilities or sprinkler line locations prior to excavating any holes.
- D.** Before you discard your cartons fill out the form below.
- The carton I.D. stamp is located on the end of each carton.
  - Please retain this information for future reference. You will need this information if you contact the Consumer Relations Department.

**PRODUCT NUMBER: YM12810**

CARTON I.D. STAMP: \_ \_ \_ \_ \_ (Box 1)

CARTON I.D. STAMP: \_ \_ \_ \_ \_ (Box 2)

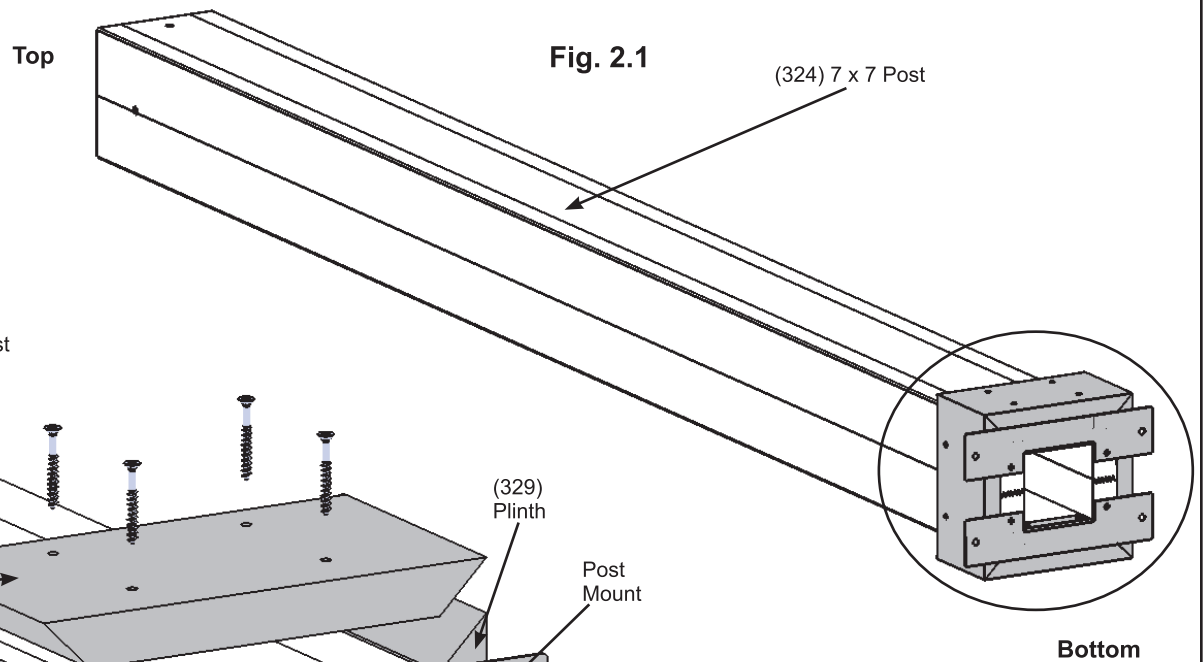
CARTON I.D. STAMP: \_ \_ \_ \_ \_ (Box 3)

## Step 2: Post Assemblies

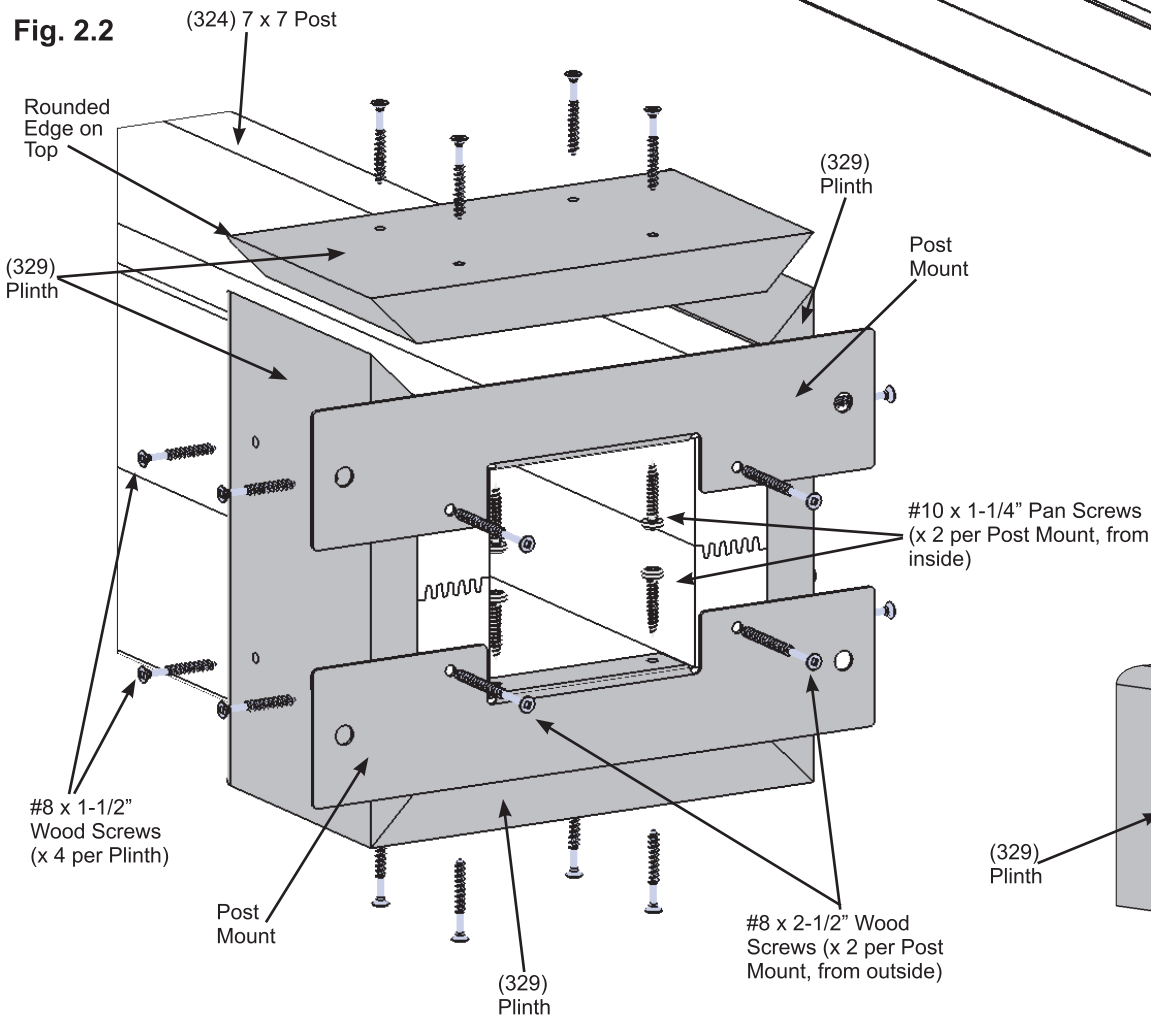
**A:** At the bottom of one (324) 7 x 7 Post place two Post Mounts tight to the bottom and inside faces as shown in fig. 2.1 and 2.2. Attach with two #10 x 1-1/4" Pan Screws per mount from the inside and two #8 x 2-1/2" Wood Screws per bracket from the outside.

**B:** Place one (329) Plinth flush to the bottom and tight to the Post Mounts on each side of the (324) 7 x 7 Post and attach with four #8 x 1-1/2" Wood Screws per plinth. Rounded edges on top. (fig. 2.1, 2.2 and 2.3)

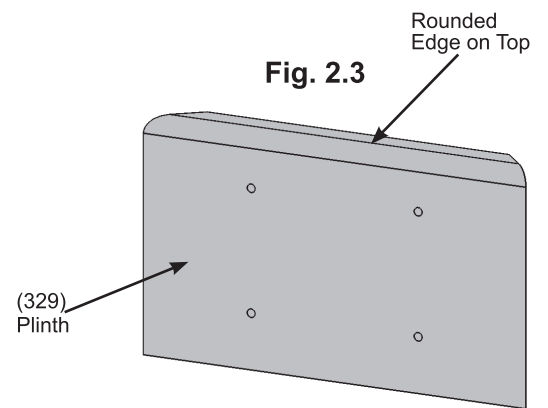
**C:** Repeat Steps A and B three more times to make four Post Assemblies.



**Fig. 2.2**



**Fig. 2.3**



### Wood Parts

4 x (324) 7 x 7 Post 177.8 x 177.8 x 2387.6 mm (7 x 7 x 94")  
 16 x (329) Plinth 23.8 x 133.4 x 225.4 mm (5/4 x 6 x 8-7/8")

### Hardware

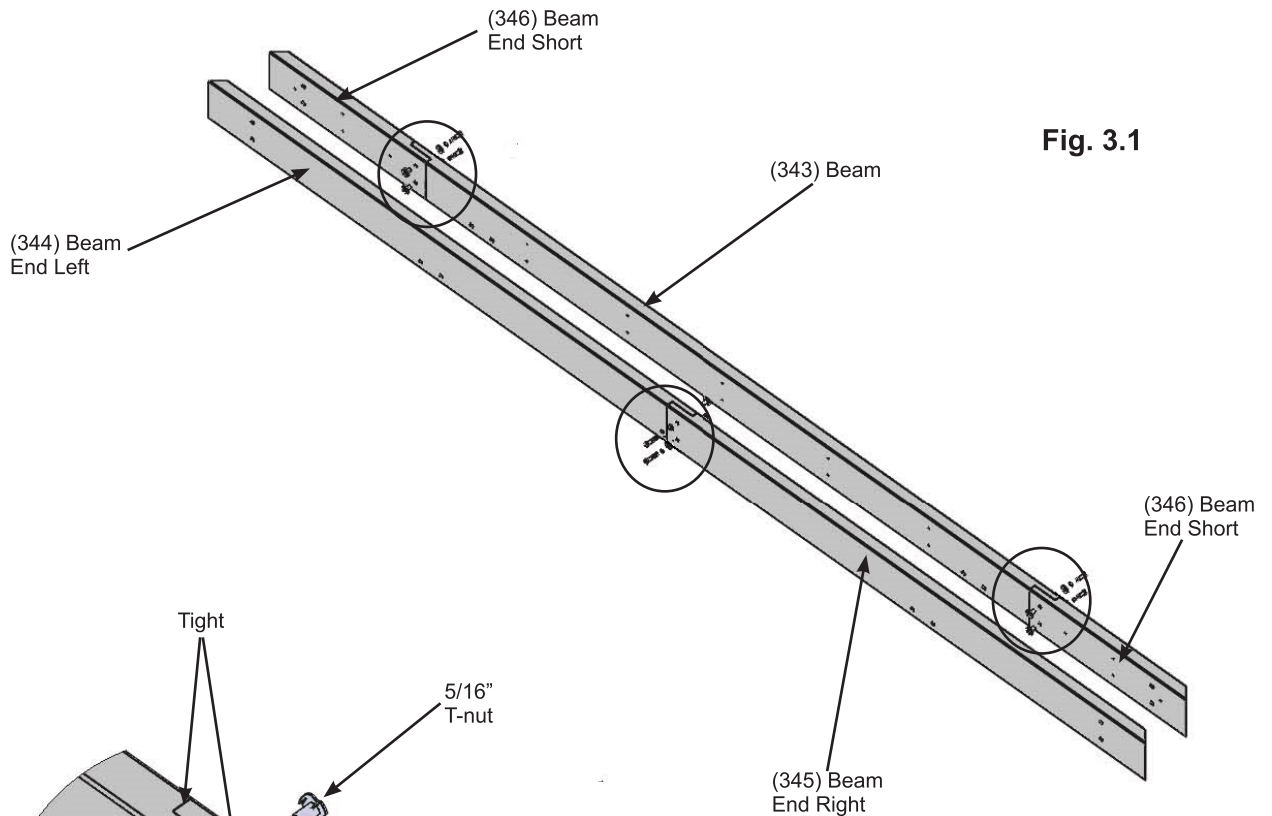
16 x #10 x 1-1/4" Pan Screw  
 16 x #8 x 2-1/2" Wood Screw  
 64 x #8 x 1-1/2" Wood Screw  
 8 x Post Mount

# Step 3: Beam Assembly Part 1

**A:** Connect one (344) Beam End Left and one (345) Beam End Right using two 5/16 x 1-1/2" Hex Bolts (with 5/16" lock washer, 1/4 - 5/16" large washer and 5/16" t-nut) as shown in fig. 3.1 and 3.2.

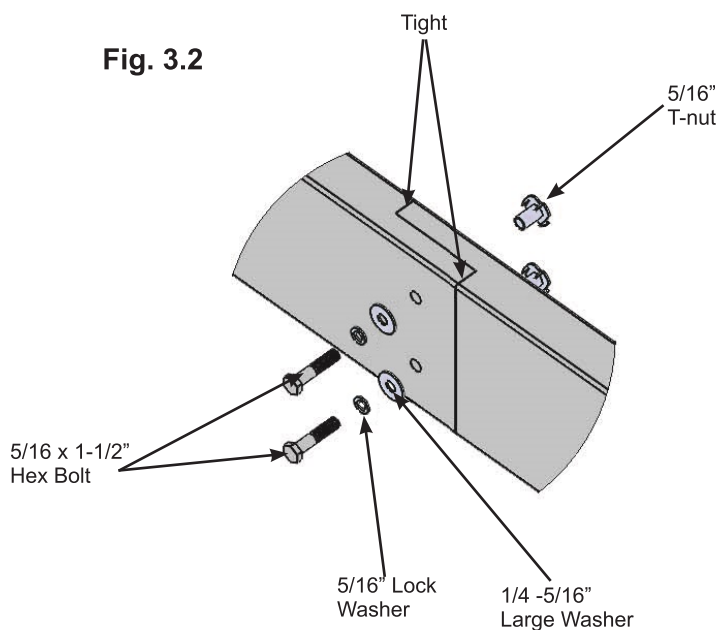
**B:** Connect one (346) Beam End Short to each end of one (343) Beam using two 5/16 x 1-1/2" Hex Bolts (with 5/16" lock washer, 1/4 - 5/16" large washer and 5/16" t-nut) per end as shown in fig. 3.1 and 3.2.

**C:** Repeat Steps A and B three more times to make four Beam Short Assemblies and four Beam End Assemblies.

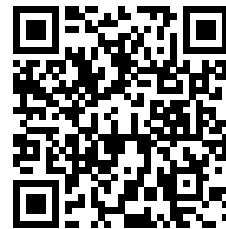


**Fig. 3.1**

**Fig. 3.2**



***Make sure bolt heads are on the outside of each Beam Assembly***



<http://bit.ly/1EALDEx>

## Wood Parts

- 4 x (344) Beam End Left 38.1 x 139.7 x 1790.7 mm (1-1/2 x 5-1/2 x 70-1/2")
- 4 x (345) Beam End Right 38.1 x 139.7 x 1790.7 mm (1-1/2 x 5-1/2 x 70-1/2")
- 8 x (346) Beam End Short 38.1 x 139.7 x 584.2 mm (1-1/2 x 5-1/2 x 23")
- 4 x (343) Beam 38.1 x 139.7 x 2413 mm (1-1/2 x 5-1/2 x 95")

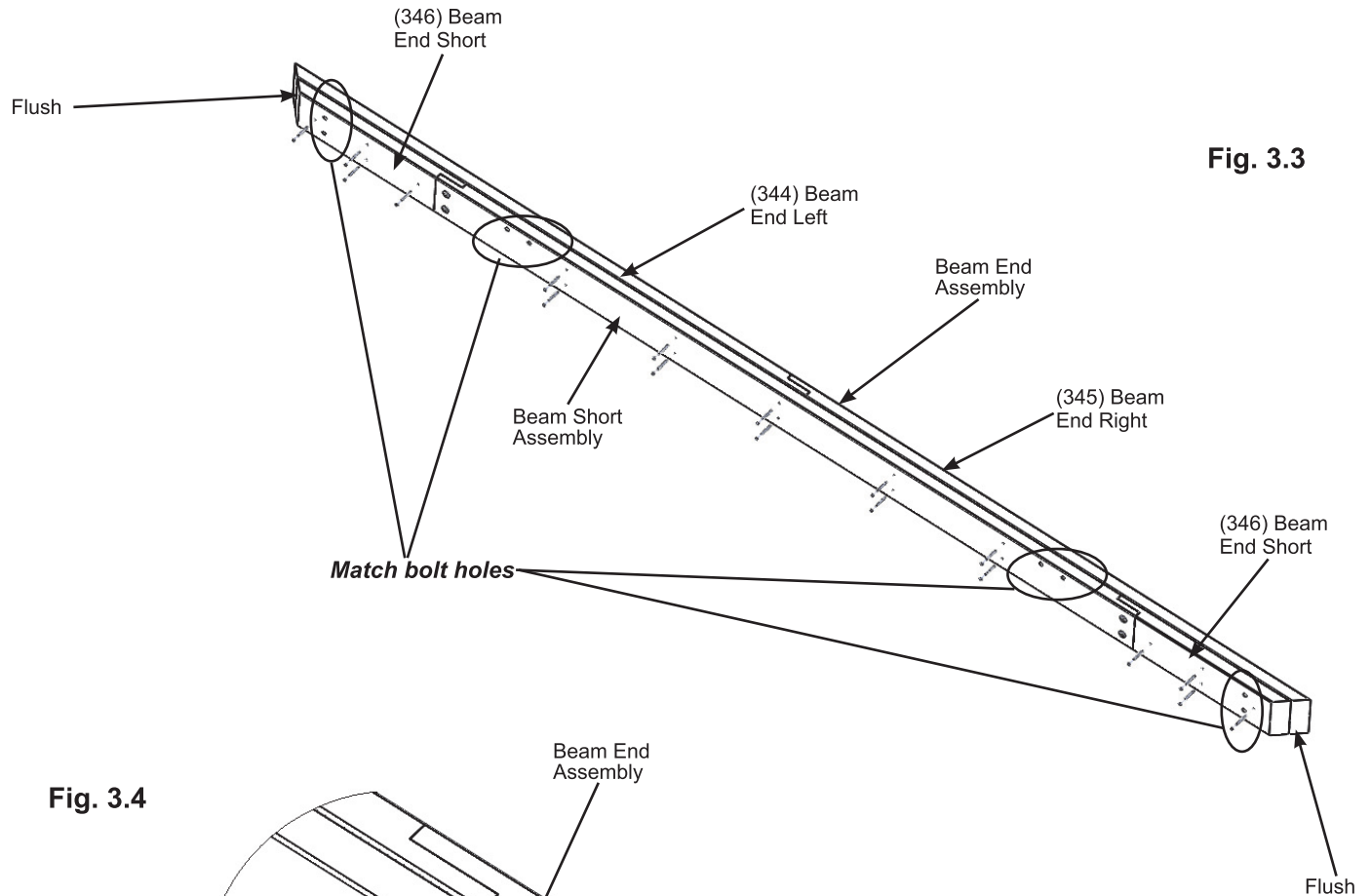
## Hardware

- 24 x 5/16 x 1-1/2" Hex Bolt  
(5/16" lock washer, 1/4-5/16" large washer, 5/16" t-nut)

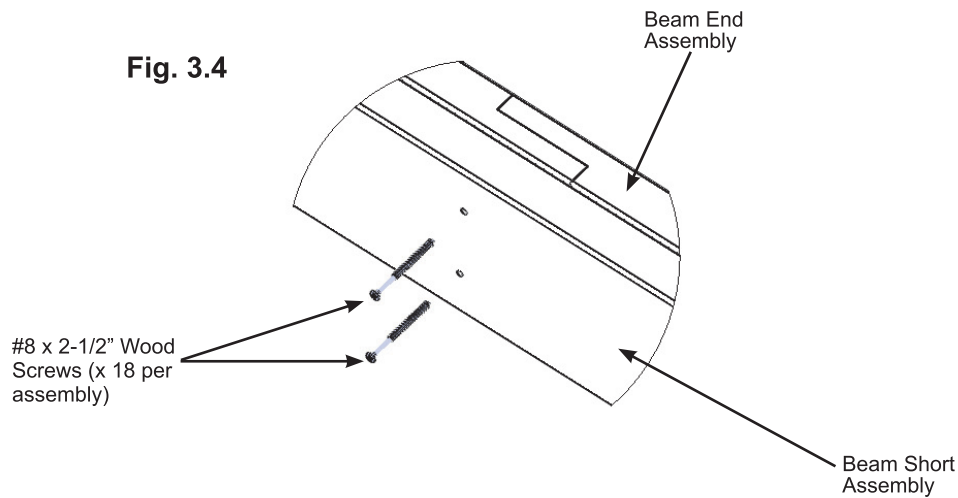
## Step 3: Beam Assembly Part 2

**D:** Place one Beam Short Assembly on one Beam End Assembly so the ends are flush. Match the bolt holes in each (346) Beam End Short with the bolt holes in (344) Beam End Left and (345) Beam End Right. Attach with 18 #8 x 2-1/2" Wood Screws. (fig. 3.3 and 3.4)

**E:** Repeat Step D three more times to make four Beam Assemblies.



**Fig. 3.3**



**Fig. 3.4**

### Hardware

72 x #8 x 2-1/2" Wood Screw



# Step 4: Frame Assembly and Anchoring Part 1



**A:** Move your Post Assemblies to the final location. Make sure the ground is flat and level before continuing assembly.

**B:** With one person at each Post stand two complete Post Assemblies. A third person places one Beam Assembly against the outside of each Post, flush to the tops and outside corners. Notice bolt hole orientation on the Beam Assembly. A fourth person attaches Beam to Post with one 3/8 x 10-1/2" Hex Bolt (with two 3/8" large washers and one 3/8" lock nut) per Post. The distance from the outside of one Post to the outside of the second Post should be 11' 0". (fig. 4.1, 4.2 and 4.3)

**C:** Continue until all four Beam Assemblies are attached and the corners are tight together. (fig. 4.1 and 4.2) See fig. 4.3 for accurate positioning of Posts.

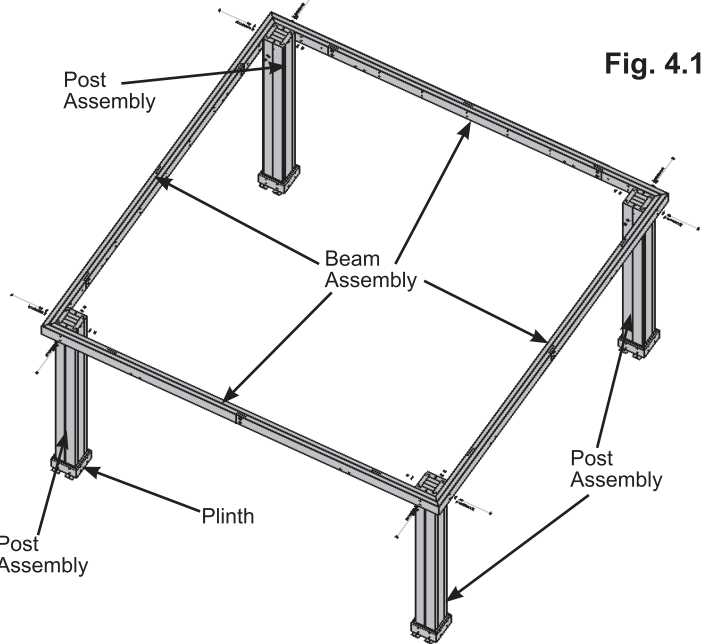


Fig. 4.1

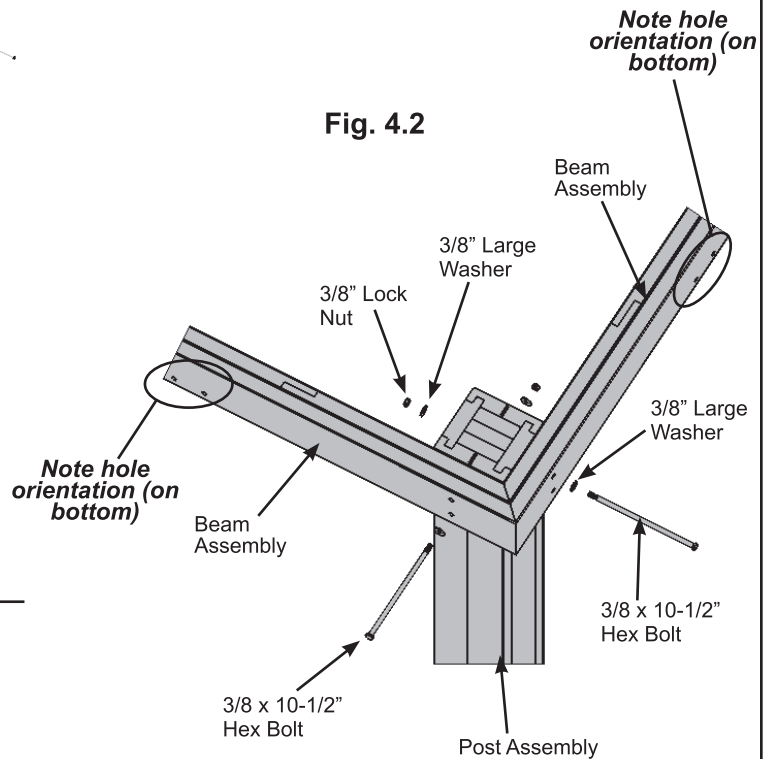
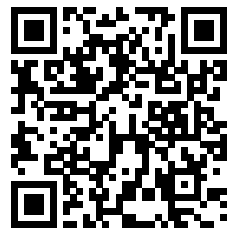
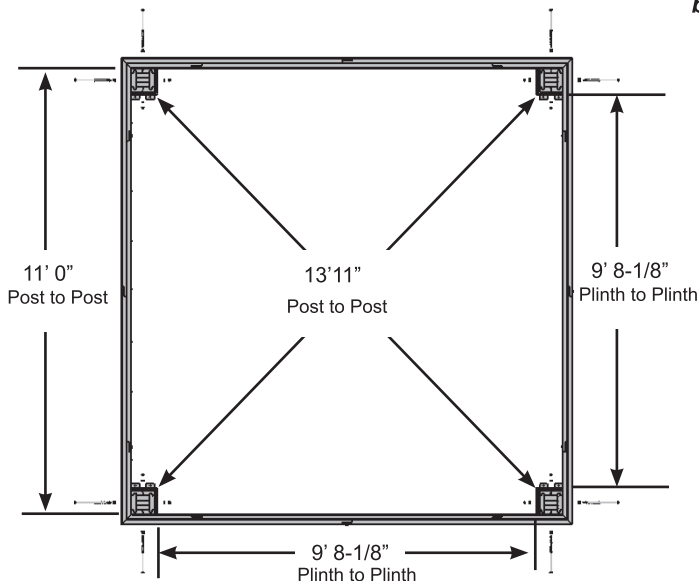


Fig. 4.2

Fig. 4.3



<http://bit.ly/1KufUGU>

## Hardware

8 x 3/8 x 10-1/2" Hex Bolt (3/8" large washer x 2, 3/8" lock nut)

## Step 4: Frame Assembly and Anchoring Part 2

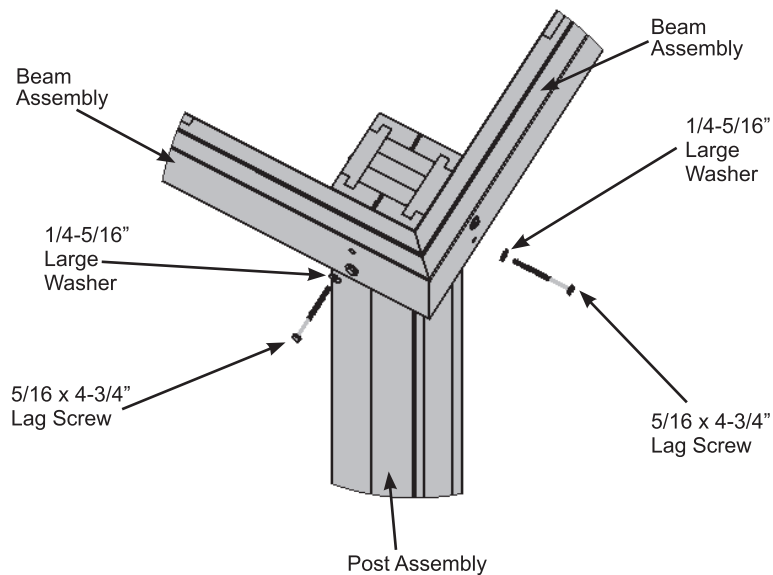


**D:** Make sure each corner is square and level then attach Beam Assemblies to Post Assemblies with two 5/16 x 4-3/4" Lag Screws (with 1/4-5/16" large washer) per corner. (fig. 4.4)

**E:** Depending on what you are placing the Pergola Room on will determine how you anchor it to that surface. Please refer to pages 6 and 7 for installation examples.

***Any hardware or extra materials for mounting will have to be purchased in advance.***

**Fig. 4.4**



### Hardware

8 x 5/16 x 4-3/4" Lag Screw (1/4-5/16" large washer)

# Step 5: Attach Gussets and Roof Brackets



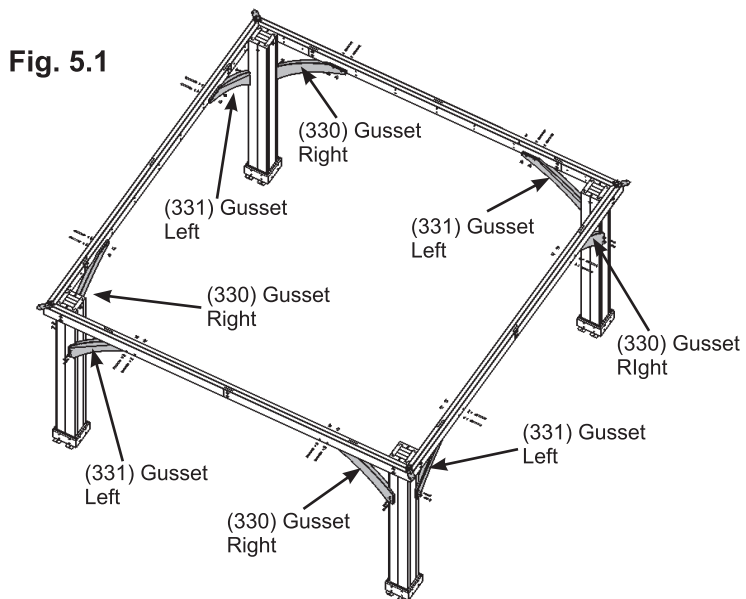
**Note:** The bevelled ends on each gusset should always face away from the wood it is attaching to.

**A:** Make sure the assembly is still square and level then facing one Beam Assembly place one (330) Gusset Right on the right hand side so the top fits tight to the Beam Assembly and the bottom fits tight to the Post Assembly. Attach gusset to Beam Assembly with two 5/16 x 3-3/4" Hex Bolts (with 5/16" lock washer, 1/4-5/16" large washer and 5/16" t-nut) and to Post Assembly with two 1/4 x 3" Hex Lags (with 1/4-5/16" large washer). (fig. 5.1, 5.2 and 5.3)

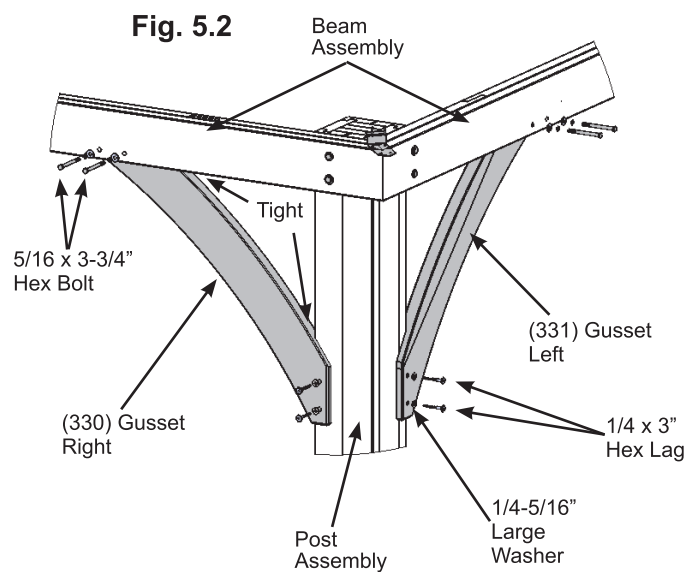
**B:** Repeat Step A on the left hand side with one (331) Gusset Left. (fig. 5.1, 5.2 and 5.3)

**C:** Repeat Steps A and B for each Beam Assembly/Post Assembly. (fig. 5.1, 5.2 and 5.3)

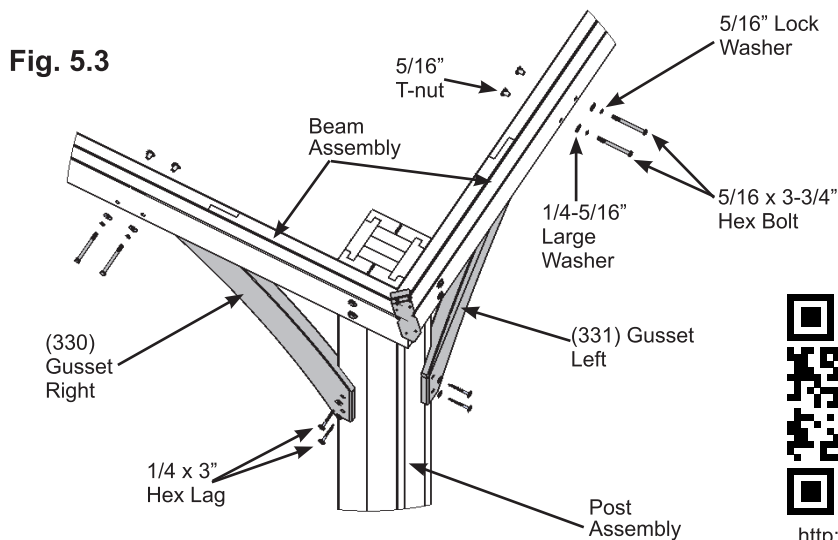
**D:** At each corner, tight to the outside edges of the joining Beam Assemblies attach one Roof to Post Bracket with two #10 x 1-1/4" Pan Screws. (fig. 5.3 and 5.4)



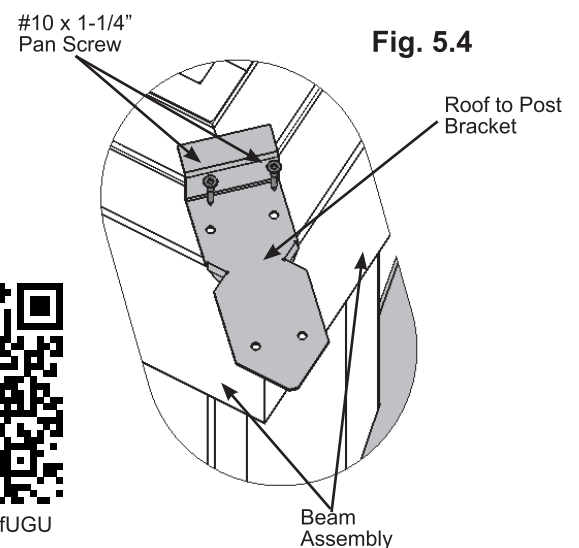
**Fig. 5.1**



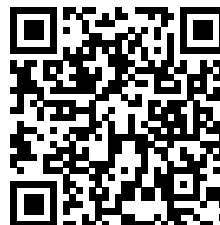
**Fig. 5.2**



**Fig. 5.3**



**Fig. 5.4**



<http://bit.ly/1KufUGU>

### Wood Parts

4 x (330) Gusset Right 38.1 x 190.5 x 1003.3 mm (1-1/2 x 7-1/2 x 39-1/2")

4 x (331) Gusset Left 38.1 x 190.5 x 1003.3 mm (1-1/2 x 7-1/2 x 39-1/2")

### Hardware

16 x 1/4 x 3" Hex Lag (1/4-5/16" large washer)

16 x 5/16 x 3-3/4" Hex Bolt (5/16" lock washer, 1/4-5/16" large washer, 5/16" t-nut)

8 x #10 x 1-1/4" Pan Screw

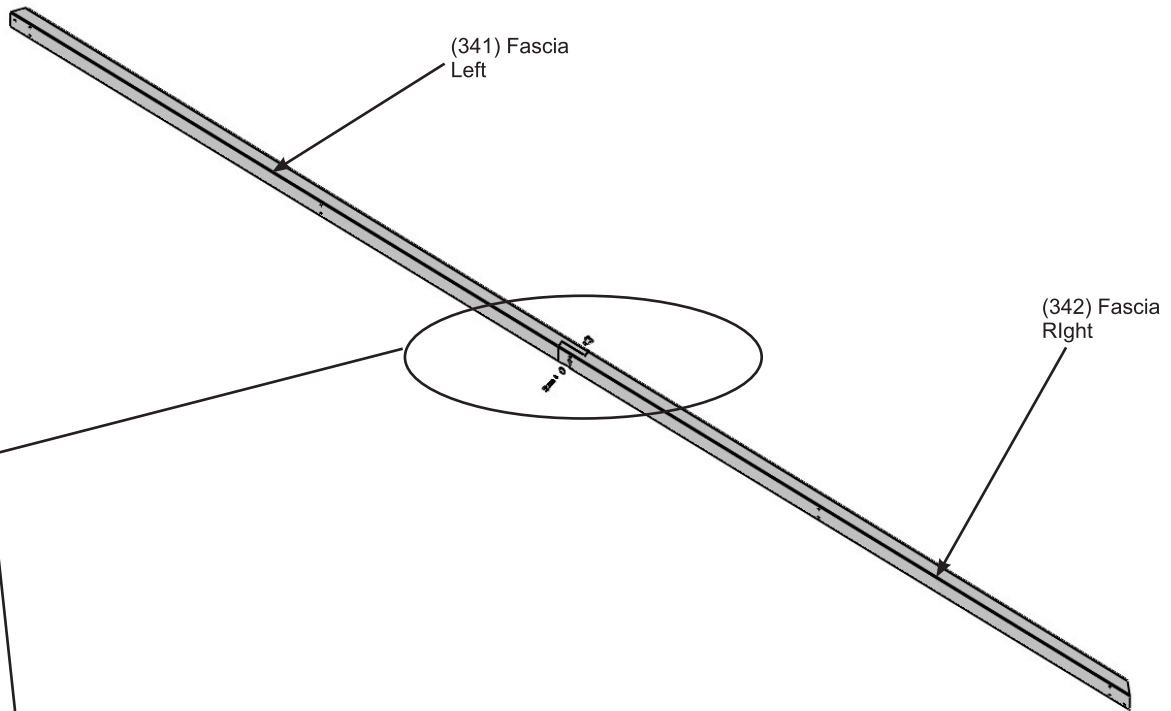
4 x Roof to Post Bracket

## Step 6: Fascia Beam Assembly

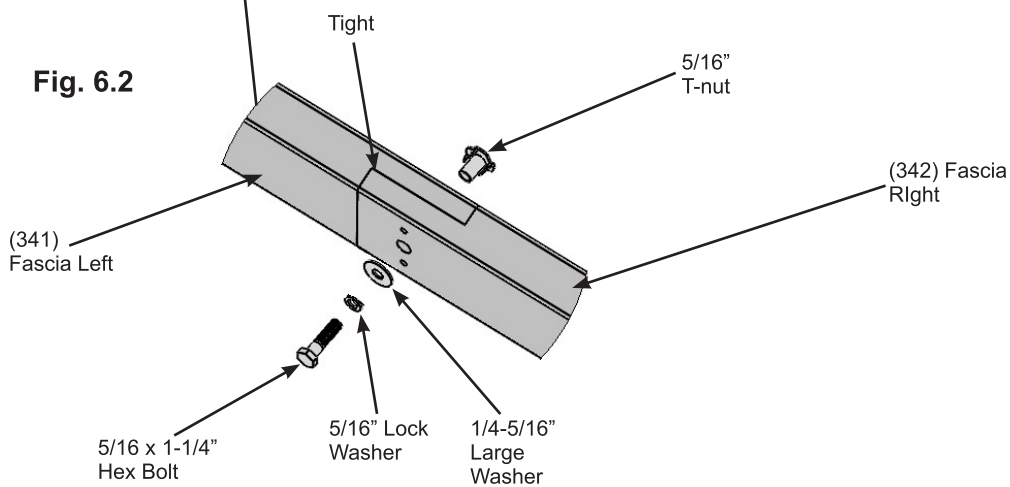
**A:** Tightly connect one (341) Fascia Left and one (342) Fascia Right using one 5/16 x 1-1/4" Hex Bolt (with 5/16" lock washer, 1/4-5/16" large washer and 5/16" t-nut) as shown in fig. 6.1 and 6.2.

**B:** Repeat Step A three more times to make four Fascia Beam Assemblies.

**Fig. 6.1**



**Fig. 6.2**



<http://bit.ly/1KufXCB>

### Wood Parts

- 4 x (341) Fascia Left 31.8 x 82.6 x 1866.9 mm (1-1/4 x 3-1/4 x 73-1/2")
- 4 x (342) Fascia Right 31.8 x 82.6 x 1866.9 mm (1-1/4 x 3-1/4 x 73-1/2")

### Hardware

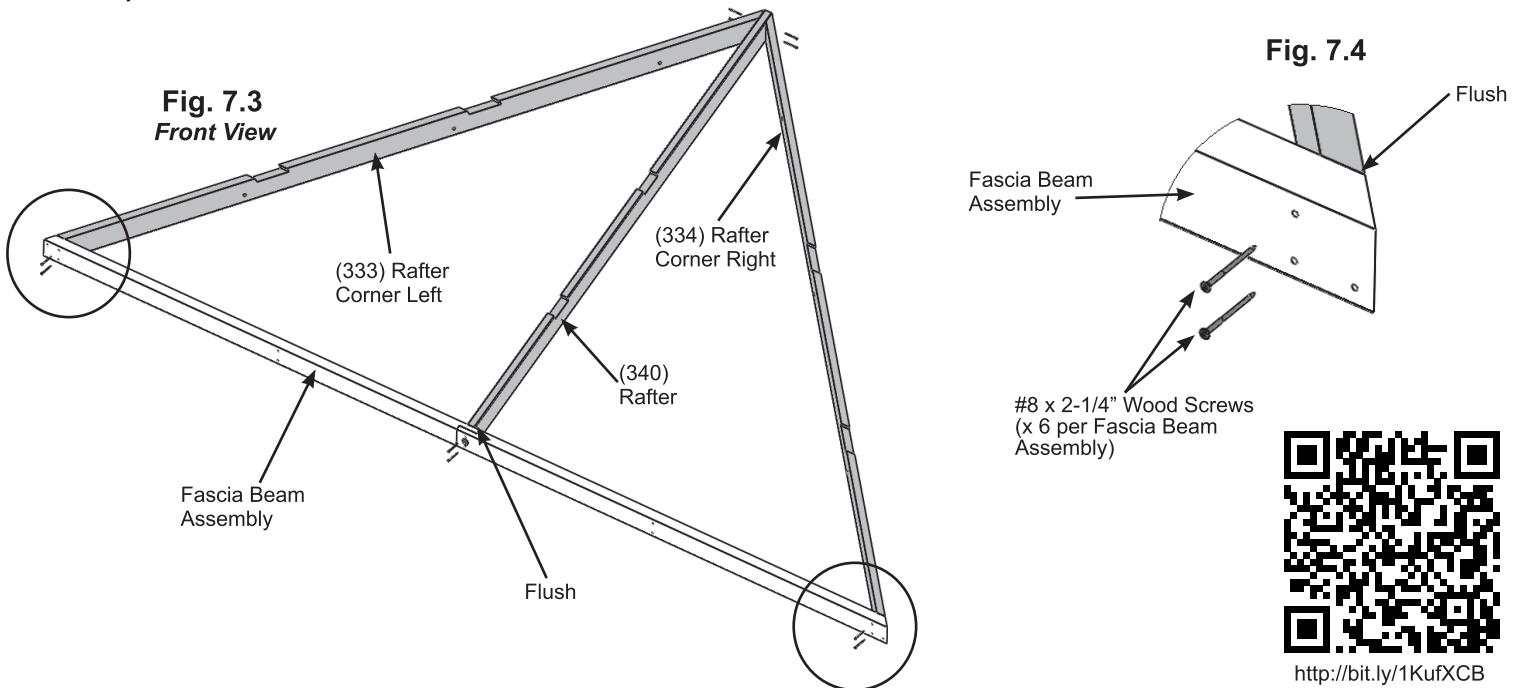
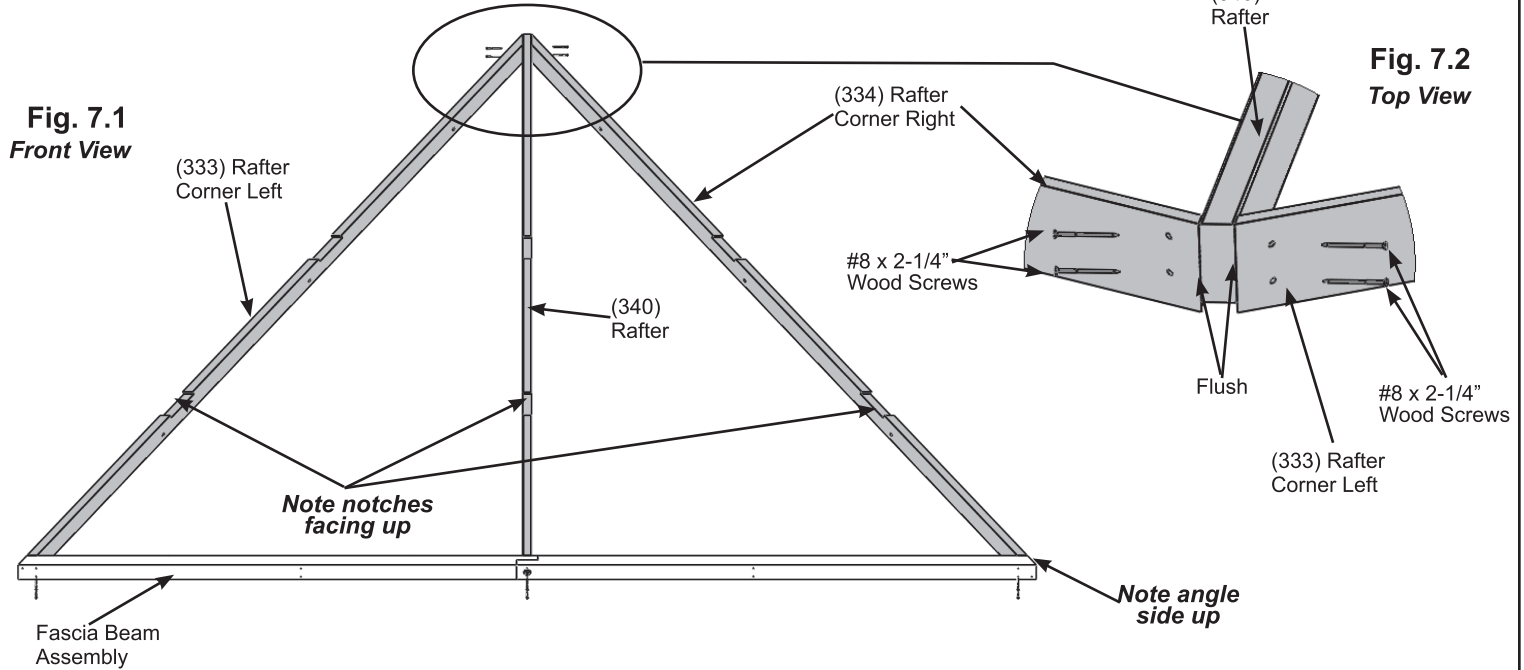
- 4 x 5/16 x 1-1/4" Hex Bolt (5/16" lock washer, 1/4-5/16" large washer, 5/16" t-nut)

# Step 7: Roof Rafter Assembly Part 1

**A:** On each side of one (340) Rafter place one (333) Rafter Corner Left and one (334) Rafter Corner Right so the tops and edges are flush then attach with two #8 x 2-1/4" Wood Screws per side. (Fig. 7.1 and 7.2)

**B:** Place Fascia Beam Assembly from Step 6 on the bottom of (333) Rafter Corner Left, (334) Rafter Corner Right and (340) Rafter so the sides are flush then attach with two #8 x 2-1/4" Wood Screws at each end and two in the middle. (fig. 7.1, 7.3 and 7.4)

**C:** Repeat Steps A and B three more times to make four Roof Rafter Assemblies.



<http://bit.ly/1KufXCB>

## Wood Parts

- 4 x (340) Rafter 31.8 x 76.2 x 1937.1 mm (1-1/4 x 3 x 76-1/4")
- 4 x (333) Rafter Corner Left 25.4 x 88.9 x 2631.5 mm (1 x 3-1/2 x 103-13/16")
- 4 x (334) Rafter Corner Right 25.4 x 88.9 x 2631.5 mm (1 x 3-1/2 x 103-13/16")

## Hardware

- 40 x #8 x 2-1/4" Wood Screw

# Step 7: Roof Rafter Assembly Part 2

**D:** Place one (337) Strap Short in the notches of (333) Rafter Corner Left, (334) Rafter Corner Right and (340) Rafter so the ends do not overhang the outside edges of the outside boards then attach with six #8 x 1-1/2" Wood Screws. (Fig. 7.5)

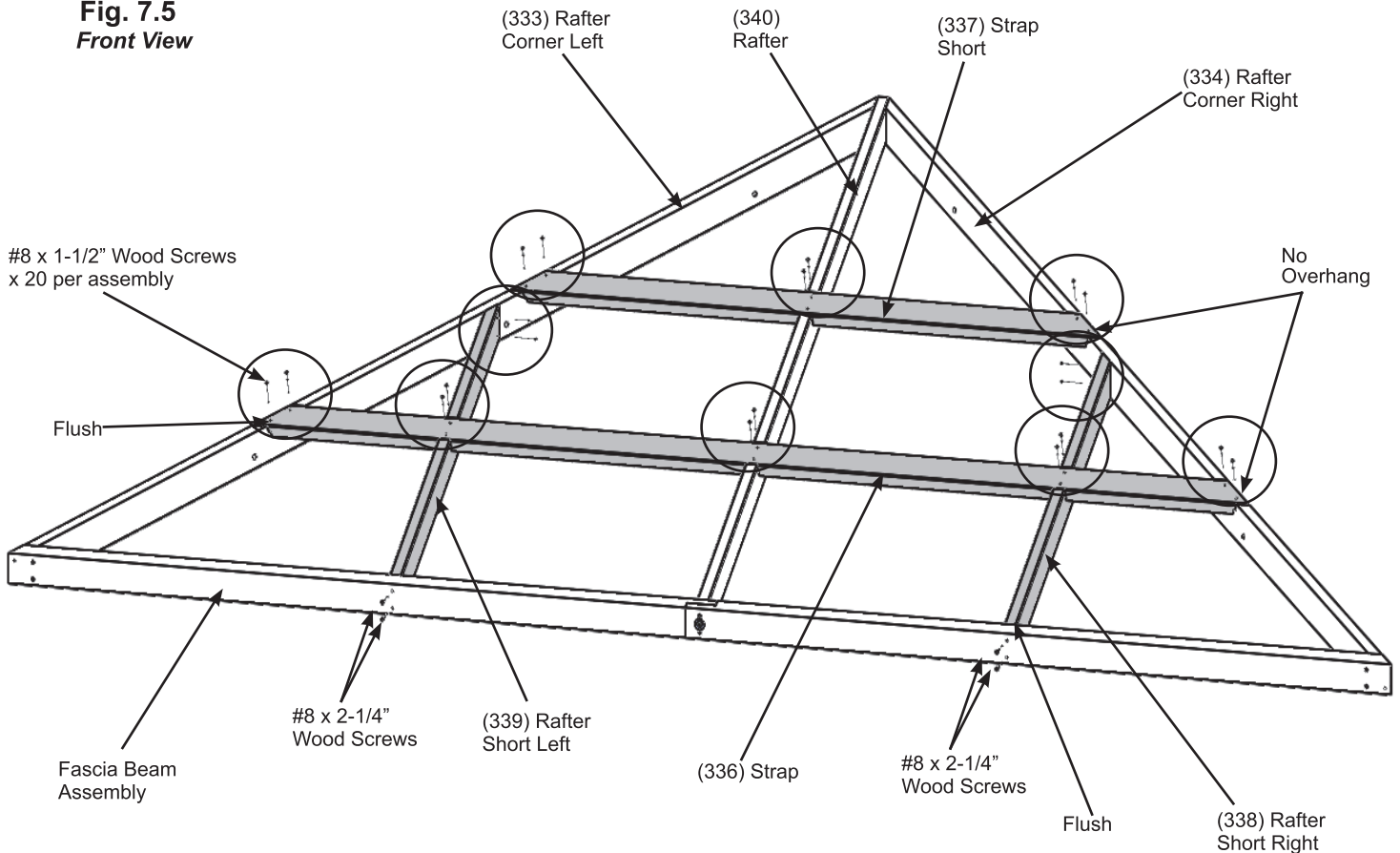
**E:** Place one (336) Strap in the notches of (333) Rafter Corner Left, (334) Rafter Corner Right and (340) Rafter so the ends do not overhang the outside edges of the outside boards. Do not attach yet. (fig. 7.5)

**F:** Place one (338) Rafter Short Right and one (339) Rafter Short Left in the notches of (336) Strap and attach as shown in fig. 7.5 with four #8 x 1-1/2" Wood Screws and two #8 x 2-1/4" Wood Screws per board.

**G:** Attach (336) Strap to (333) Rafter Corner Left, (334) Rafter Corner Right and (340) Rafter with six #8 x 1-1/2" Wood Screws. (fig. 7.5)

**H:** Complete Steps D, E, F and G for all four Roof Rafter Assemblies.

**Fig. 7.5**  
**Front View**



### Wood Parts

- 4 x (337) Strap Short 31.8 x 82.6 x 1561.3 mm (1-1/4 x 3-1/4 x 61-7/16")
- 4 x (336) Strap 31.8 x 82.6 x 2628.1 mm (1-1/4 x 3-1/4 x 103-7/16")
- 4 x (338) Rafter Short Right 31.8 x 76.2 x 1062 mm (1-1/4 x 3 x 41-13/16")
- 4 x (339) Rafter Short Left 31.8 x 76.2 x 1062 mm (1-1/4 x 3 x 41-13/16")

### Hardware

- 80 x #8 x 1-1/2" Wood Screw
- 16 x #8 x 2-1/4" Wood Screw

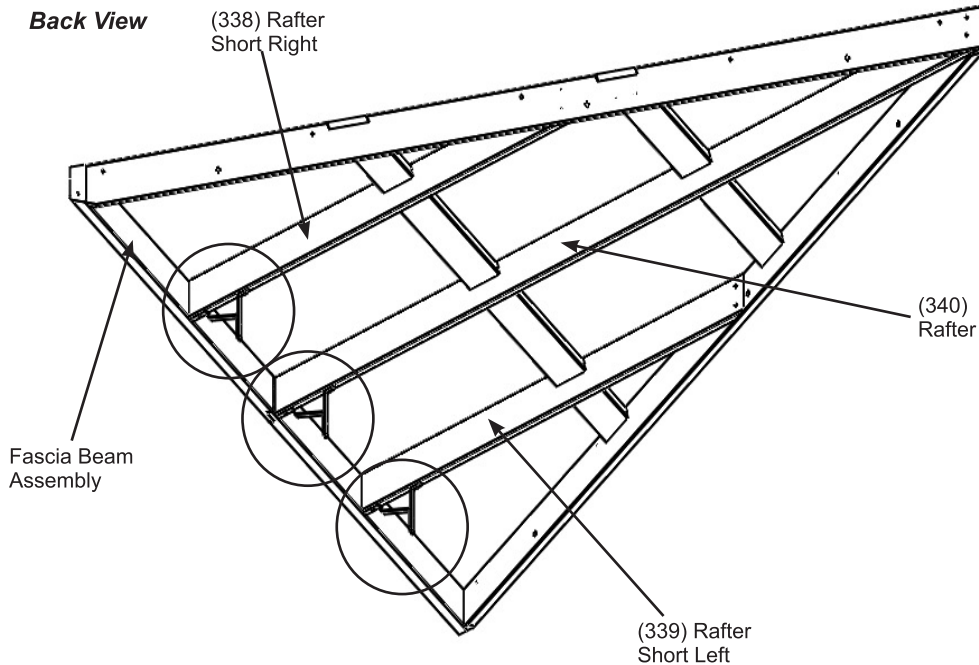


## Step 8: Attach Roof to Beam Brackets

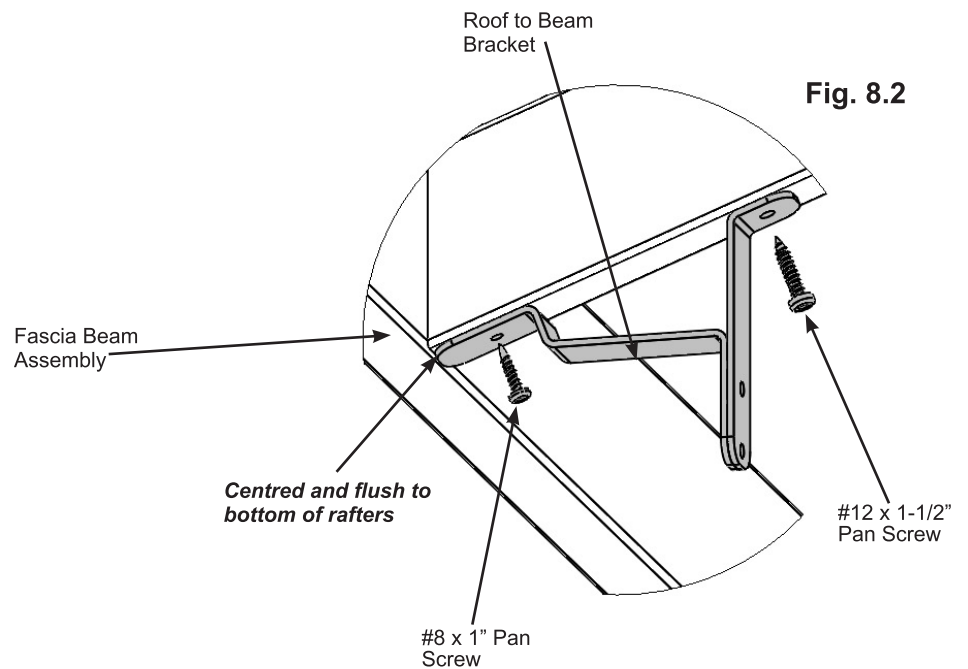
**A:** On the Back of the three Roof Rafter Assemblies, centred and flush to the bottom of (338) Rafter Short Right, (339) Rafter Short Left and (340) Rafter attach one Roof to Beam Bracket per board with one #8 x 1" Pan Screw in the bottom hole and one #12 x 1-1/2" Pan Screw in the top hole per bracket. One Roof Rafter Assembly will not have brackets. (fig. 8.1 and 8.2)

**Fig. 8.1**

**Back View**



**Fig. 8.2**

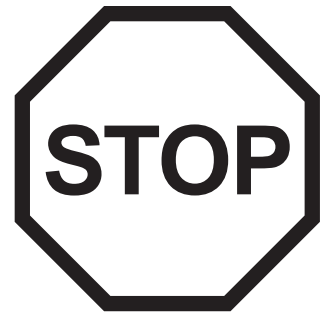
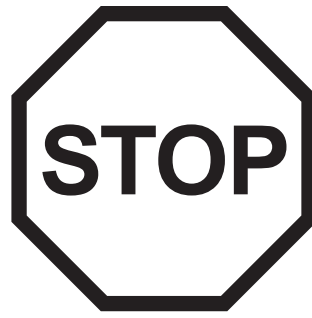
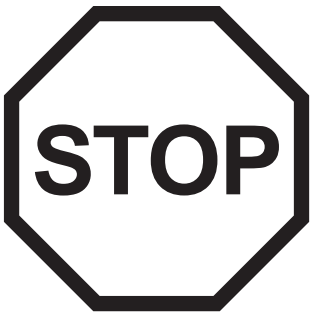


### Hardware

9 x #8 x 1" Pan Screw

9 x #12 x 1-1/2" Pan Screw

9 x Roof to Beam Bracket



# INSTALLING ROOFING MATERIAL

---

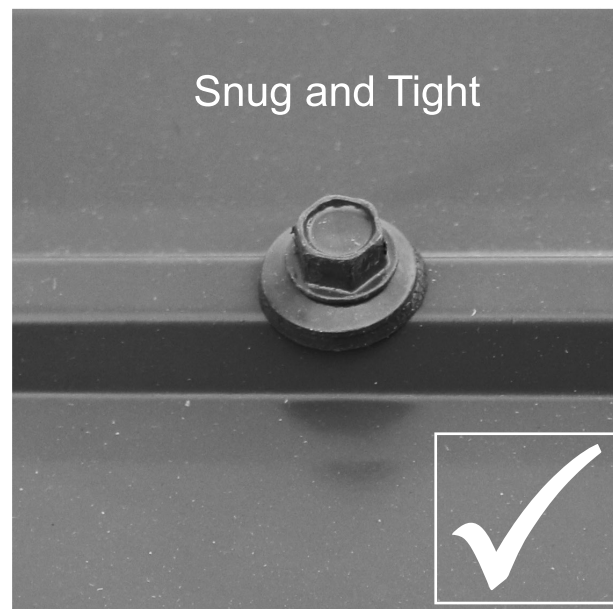
## CAUTION!

Roofing material may have sharp edges! Wear gloves!

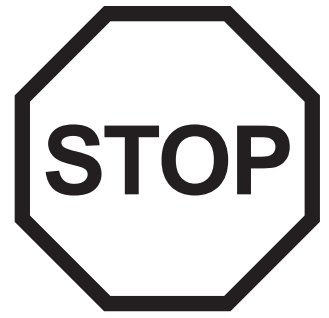
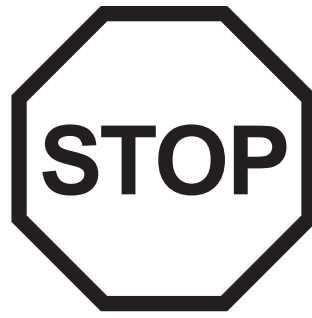
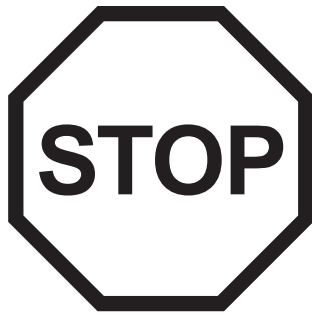
## HANDLE WITH CARE!

Place roofing material on a non-abrasive surface before assembly as it can bend, dent and scratch easily.

**WARNING – DO NOT OVER TIGHTEN ROOFING SCREWS!  
Over tightening screws will cause roofing material to crush.**



The roofing screws can easily crush the Roof Panels and Roof Edges when using a power drill. We recommend hand tightening the roofing screws so that they sit snug and tight to the roofing material.



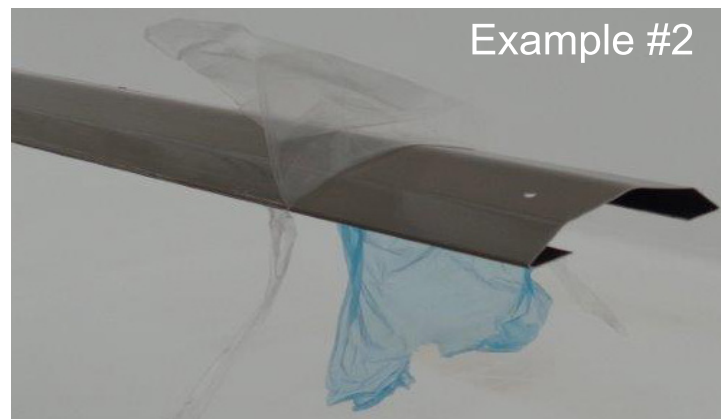
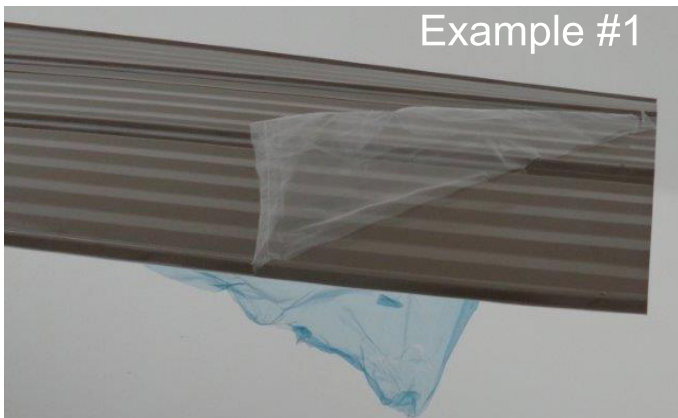
# INSTALLING ROOFING MATERIAL

---

## CAUTION!

Roofing material may have sharp edges! Wear gloves!

**BE SURE TO REMOVE ALL PLASTIC COVERING, ON BOTH SIDES OF THE ALUMINUM PANELS AND TRIM, DIRECTLY BEFORE INSTALLING EACH PIECE. *(One side is clear and the other is blue, both must be removed.)***



# Step 9: Attach Roof Panels

## Part 1

**A:** Place one Left Long Panel on the front of one Roof Rafter Assembly so it is flush to the side of (333) Rafter Corner Left and a slight overhang at the bottom of the Fascia Beam Assembly. Holes should line up with (340) Rafter. (fig. 9.1 and 9.2)

**B:** Place one Right Long Panel on Roof Rafter Assembly so it overlaps the Left Long Panel and it is flush to the side of (334) Rafter Corner Right and a slight overhang at the bottom of the Fascia Beam Assembly. (fig. 9.1 and 9.2)

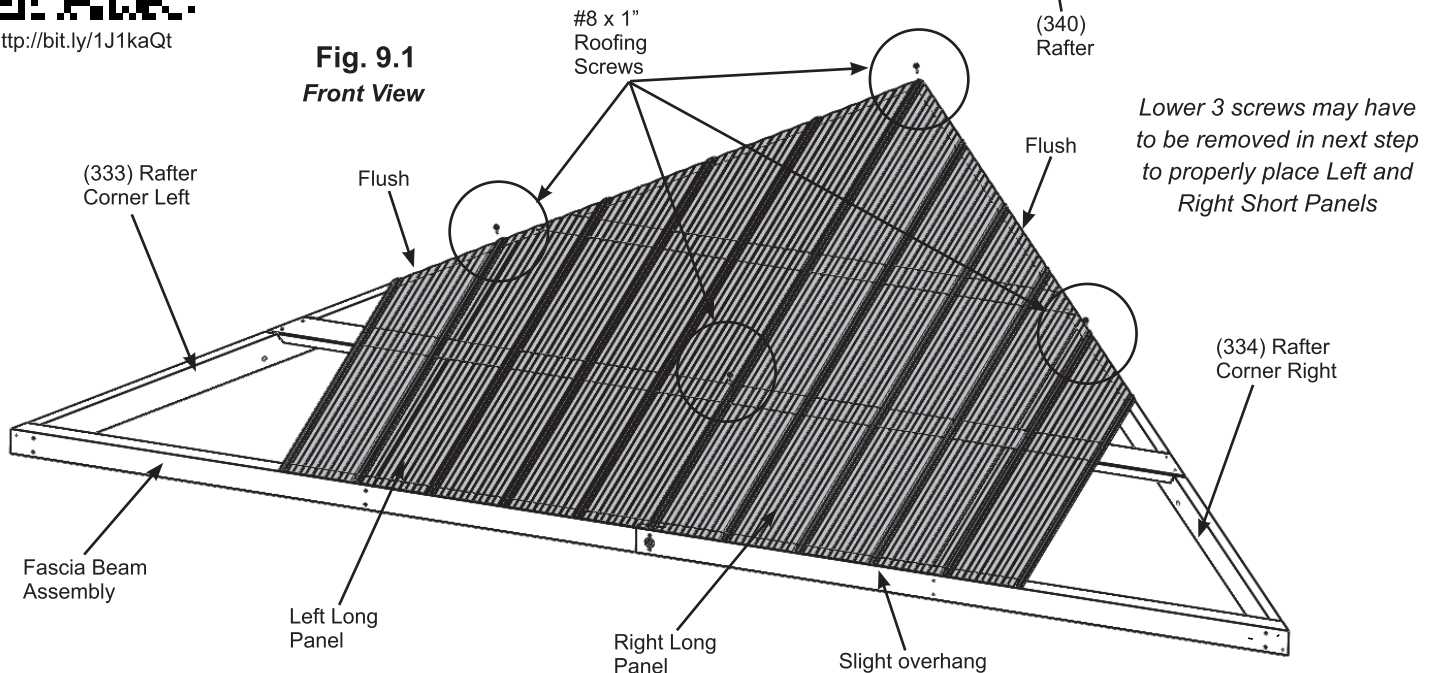
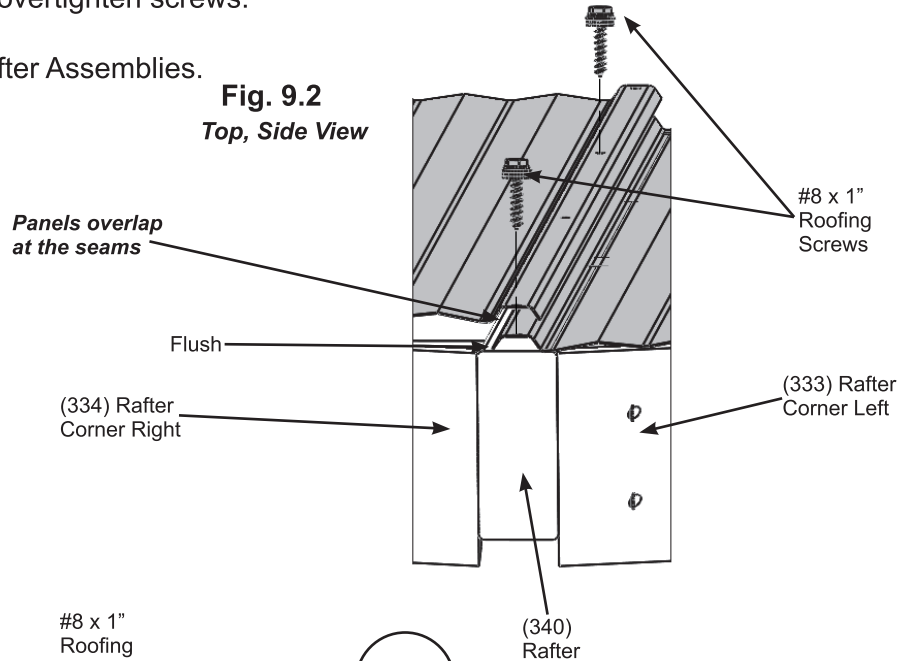
**C:** Attach both Left and Right Long Panels to Roof Rafter Assembly with four #8 x 1" Roofing Screws in locations shown in fig. 9.1. Be sure not to overtighten screws.

**D:** Repeat Steps A - C for all four Roof Rafter Assemblies.

**DO NOT overtighten screws, could cause damage to roofing material**



<http://bit.ly/1J1kaQt>



### Roof Parts

- 4 x Left Long Panel
- 4 x Right Long Panel

### Hardware

- 16 x #8 x 1" Roofing Screw



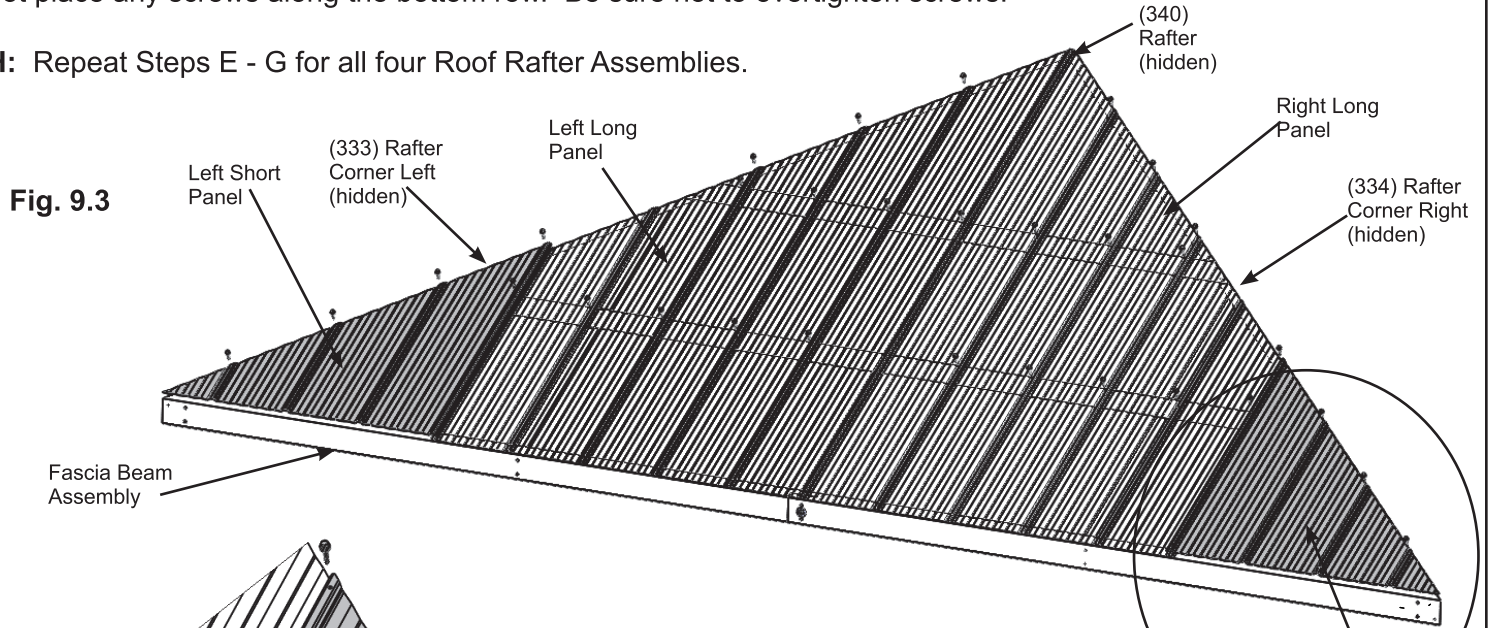
# Step 9: Attach Roof Panels Part 2

**E:** Place one Left Short Panel on Roof Rafter Assembly so it overlaps the Left Long Panel and it is flush to the sides of (333) Rafter Corner Left and a slight overhang at the bottom of the Fascia Beam Assembly. There should be no overhanging at the corners. (fig. 9.3 and 9.4)

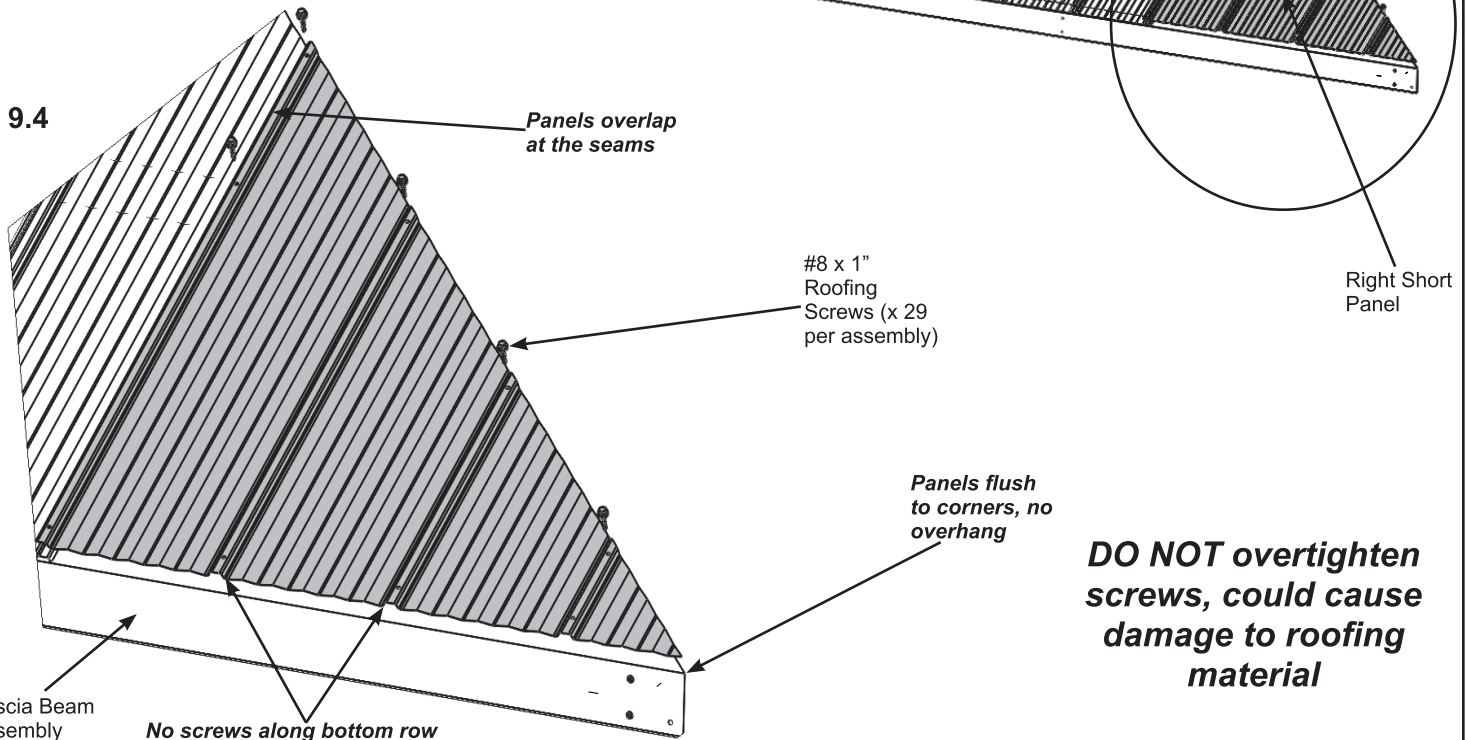
**F:** Place one Right Short Panel on Roof Rafter Assembly so it overlaps the Right Long Panel and it is flush to the side of (334) Rafter Corner Right and a slight overhang at the bottom of the Fascia Beam Assembly. There should be no overhanging at the corners. (fig. 9.3 and 9.4)

**G:** Attach all panels to Roof Rafter Assembly with 29 #8 x 1" Roofing Screws in locations shown in fig. 9.3. Do not place any screws along the bottom row. Be sure not to overtighten screws.

**H:** Repeat Steps E - G for all four Roof Rafter Assemblies.



**Fig. 9.3**



**Fig. 9.4**

**DO NOT overtighten screws, could cause damage to roofing material**

### Roof Parts

- 4 x Left Short Panel
- 4 x Right Short Panel

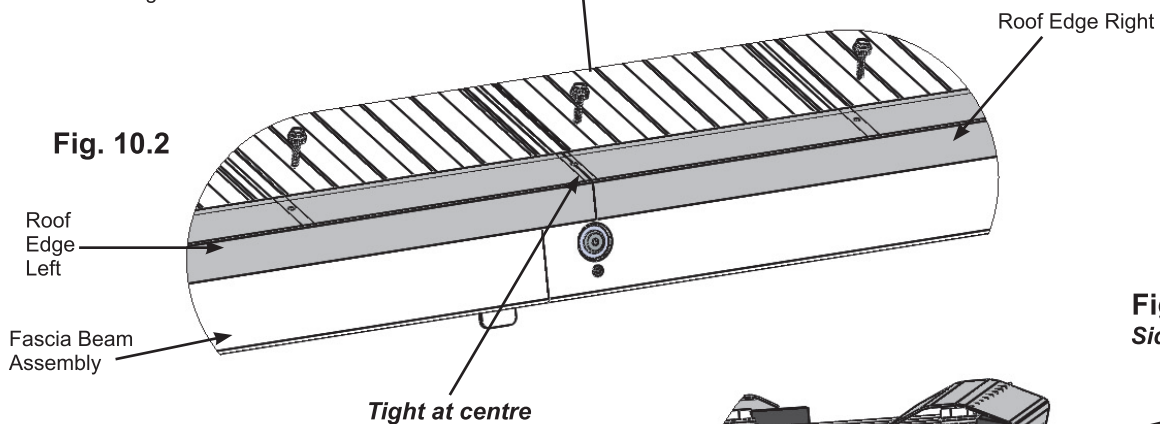
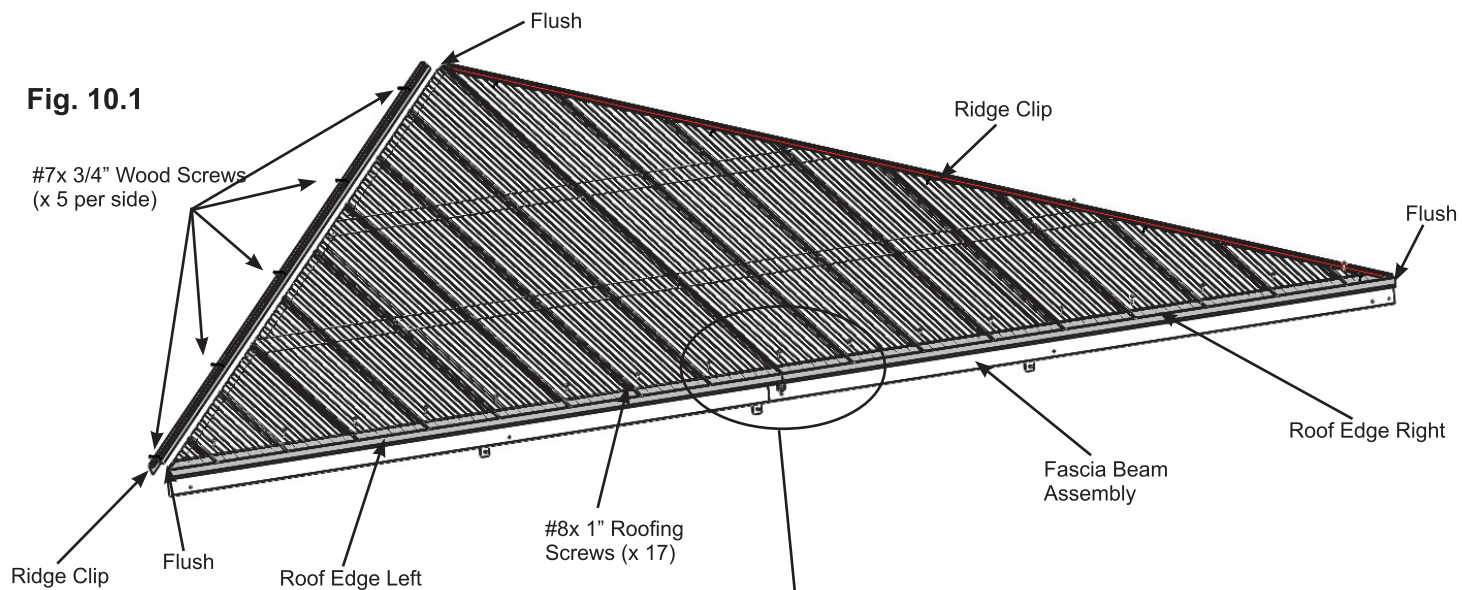
### Hardware

- 116 x #8 x 1" Roofing Screw

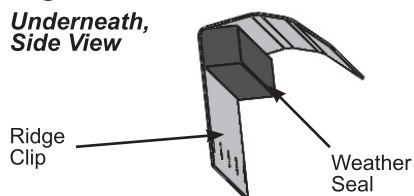
# Step 10: Attach Ridge Clips and Roof Edges

**A:** Place one Roof Edge Left and one Roof Edge Right on the bottom of each Roof Rafter Assembly so the ends are flush with the outside ends of the Fascia Beam Assembly and meet tight in the centre. Attach both Roof Edges with 17 #8 x 1" Roofing Screws per Roof Rafter assembly. (fig. 10.1 and 10.2)

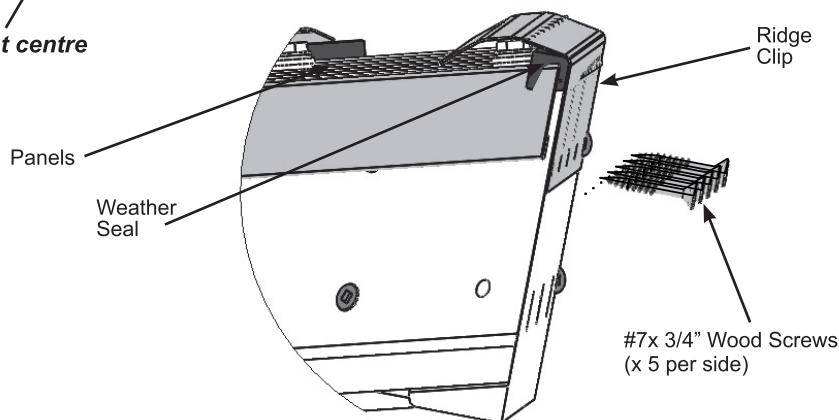
**B:** Place one Weather Seal on the inside of each Ridge Clip then place one Ridge Clip on each side of each Roof Rafter Assembly so they cover the panels and attach with five #7 x 3/4" Wood Screws per Ridge Clip. (fig. 10.1, 10.3 and 10.4)



**Fig. 10.3**  
*Underneath, Side View*



**Fig. 10.4**  
*Side View*



**Components:**

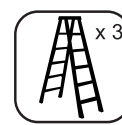
- 4 x Roof Edge Left
- 4 x Roof Edge Right
- 8 x Ridge Clip
- 8 x Weather Seal

**Hardware**

- 68 x #8 x 1" Roofing Screw
- 40 x #7 x 3/4" Wood Screw



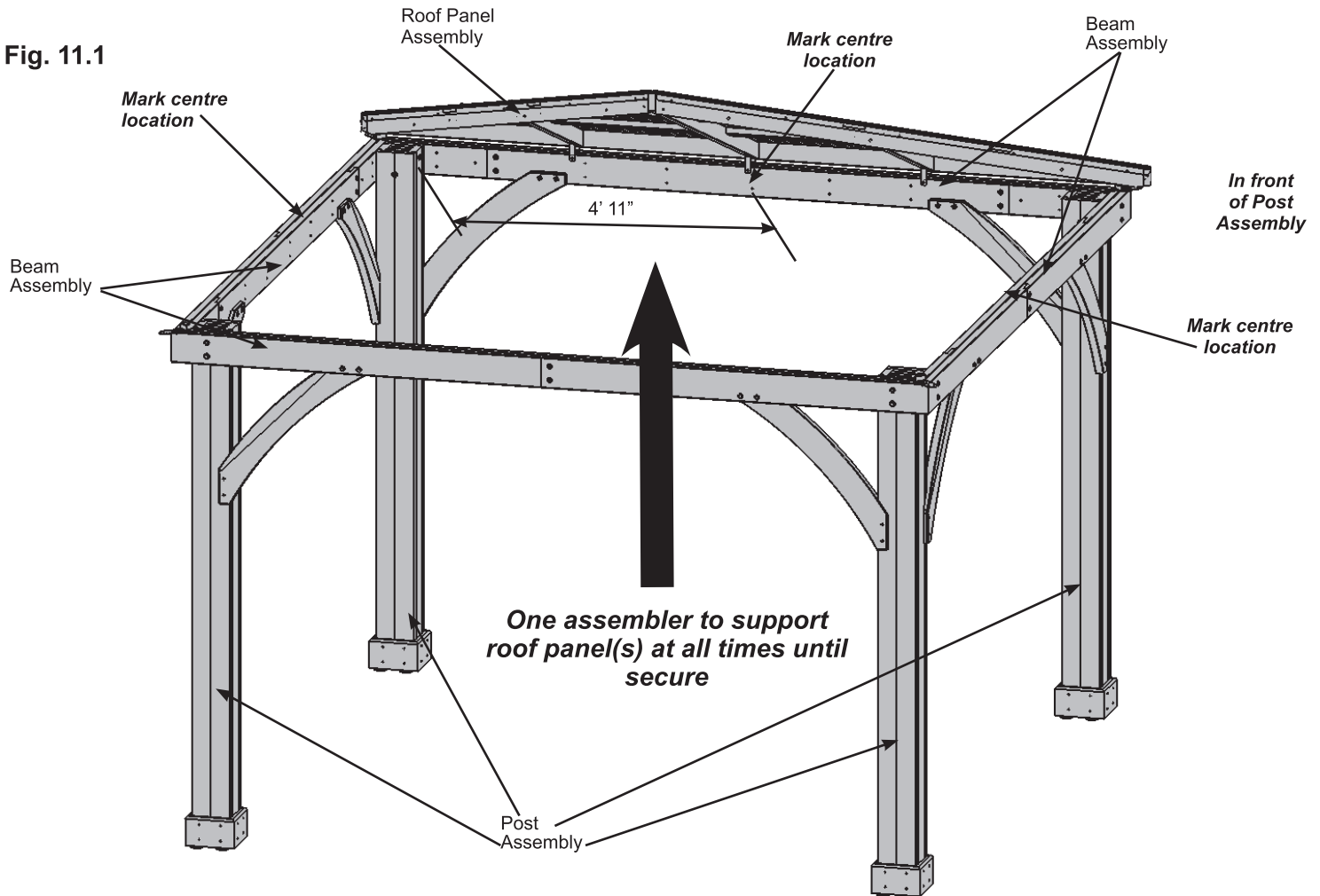
# Step 11: Attach Roof Panels to Frame Part 1



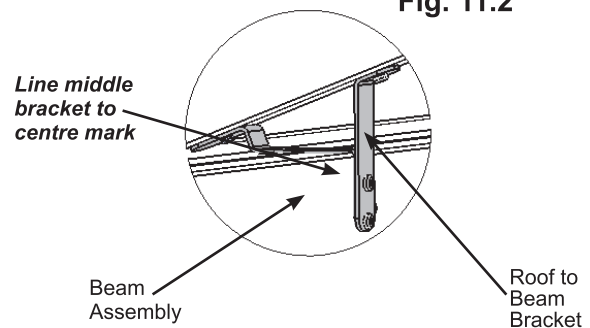
**A:** From inside of Post Assemblies measure 4' 11" to mark the centre of each Beam Assembly. (fig. 11.1)

**B:** With all four assemblers place one Roof Panel Assembly with Roof to Beam Brackets just in front of the Post Assemblies then raise it up so the middle Roof to Beam Bracket is lined up with the centre mark. (fig. 11.1 and 11.2)

**Fig. 11.1**

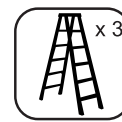


**Fig. 11.2**



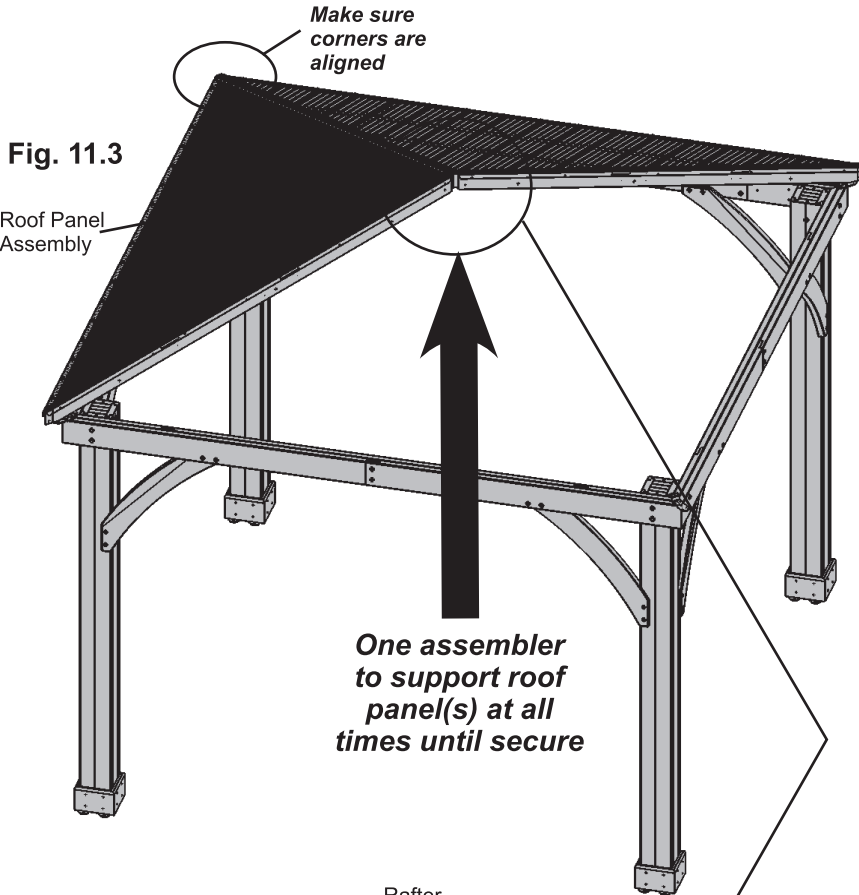
<http://bit.ly/1J1kcYq>

# Step 11: Attach Roof Panels to Frame Part 2



**C:** Lift a second Roof Panel Assembly with Roof to Beam Brackets over Beam Assembly taking care not to drag the panel on the beams. Make sure the middle Roof to Beam Bracket lines up to the centre mark and the Rafter Corners are flush with each other. **One person must remain on the centre ladder to hold both panels in place until three panels are up and secure.** (fig. 11.2, 11.3 and 11.4)

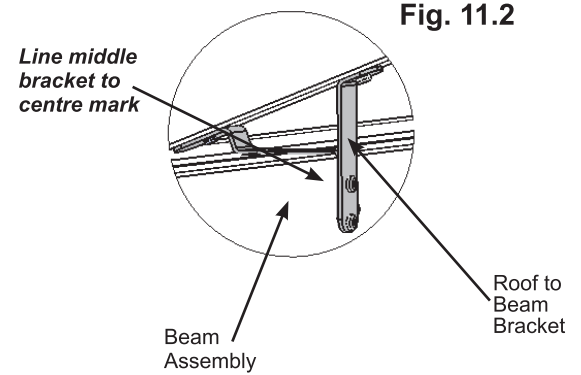
**D:** Starting at the bottom and working up connect Roof Panel Assemblies through the Rafter Corners with three 1/4 x 2-3/4" Hex Bolts (with two 1/4-5/16" large washers and one 1/4" lock nut). To align bolt holes helper in the centre may have to push up the centre of the panels and others make sure corners are aligned. Make sure all bolts are tight. (fig. 11.2 and 11.5)



**Fig. 11.3**

Roof Panel Assembly

**One assembler to support roof panel(s) at all times until secure**



**Fig. 11.2**

Line middle bracket to centre mark

Beam Assembly

Roof to Beam Bracket

1/4-5/16" Large Washer  
1/4" Lock Nut

**Fig. 11.5**

Roof Panel Assembly

Rafter Corner

1/4 x 2-3/4" Hex Bolt

**Start at bottom and work up the rafters**

**Fig. 11.4**

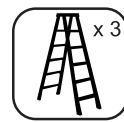
Rafter Corners

Flush

### Hardware

3 x 1/4 x 2-3/4" Hex Bolt  
(1/4-5/16" large washer x 2, 1/4" lock nut)

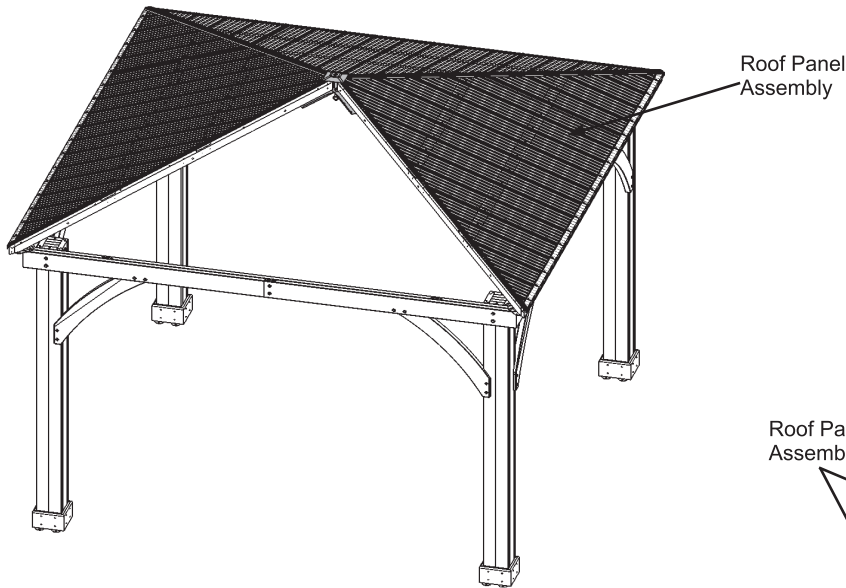
# Step 11: Attach Roof Panels to Frame Part 3



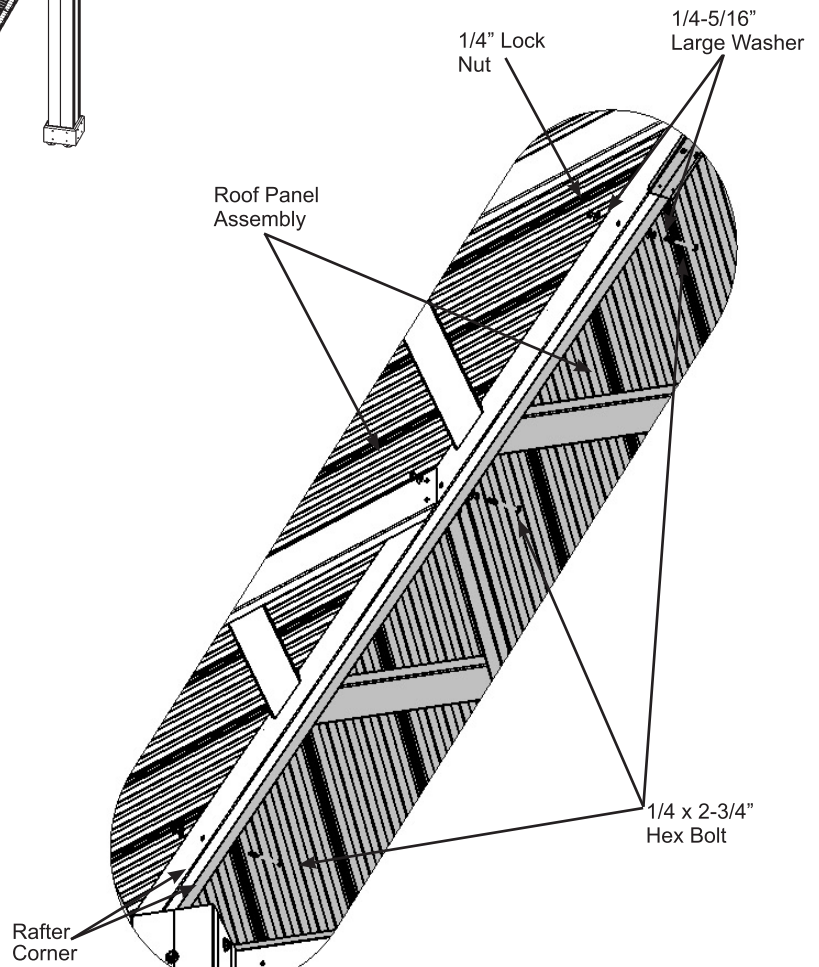
**E:** Lift third Roof Panel Assembly with Roof to Beam Brackets over Beam Assembly taking care not to drag the panel on the beams then set in place beside the second panel. Make sure the middle Roof to Beam Bracket lines up to the centre mark. (fig. 11.6)

**F:** Starting at the bottom and working up connect Roof Panel Assemblies through the Rafter Corners with three 1/4 x 2-3/4" Hex Bolts (with two 1/4-5/16" large washers and one 1/4" lock nut). To align bolt holes helper on the centre ladder may have to push up in the centre of the panels and others make sure corners are aligned. Make sure all bolts are tight. (fig. 11.7)

**Fig. 11.6**



**Fig. 11.7**



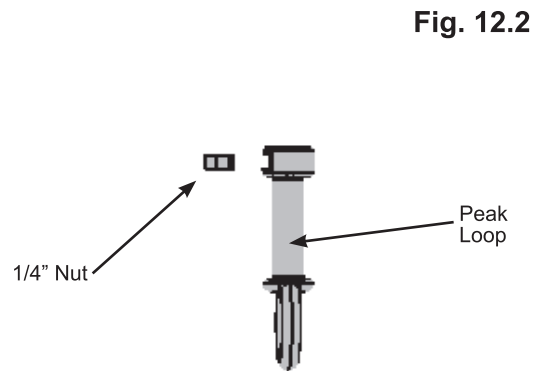
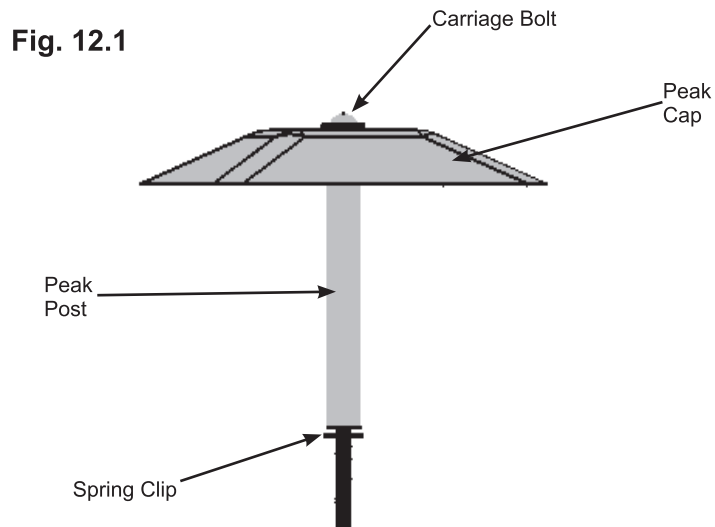
### Hardware

3 x 1/4 x 2-3/4" Hex Bolt  
(1/4-5/16" large washer x 2, 1/4" lock nut)

## Step 12: Roof Peak Assembly

**A:** Insert Carriage Bolt through the top of Peak Cap, into Peak Post then Spring Clip. The Spring Clip holds the assembly together. (fig. 12.1)

**B:** Insert 1/4" Nut into Peak Loop. Be careful nut is loose and will fall out until attached to Peak Cap Assembly. (fig. 12.2)



### Componets:

1 x Roof Peak Set	1 x Peak Cap
1 x Carriage Bolt	1 x Peak Post
1 x Peak Loop	
1 x Spring Clip	
1 x 1/4" Nut	

# Step 13: Attach Roof Peak to Roof Panels

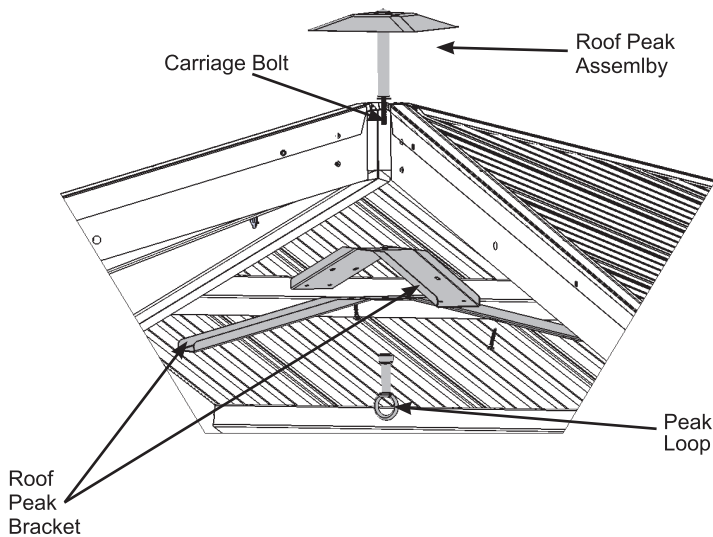


**A:** Insert Roof Peak Assembly in gap between Roof Panels. Peak Cap to be lined up with Rafter Corners. (fig. 13.1 and 13.2)

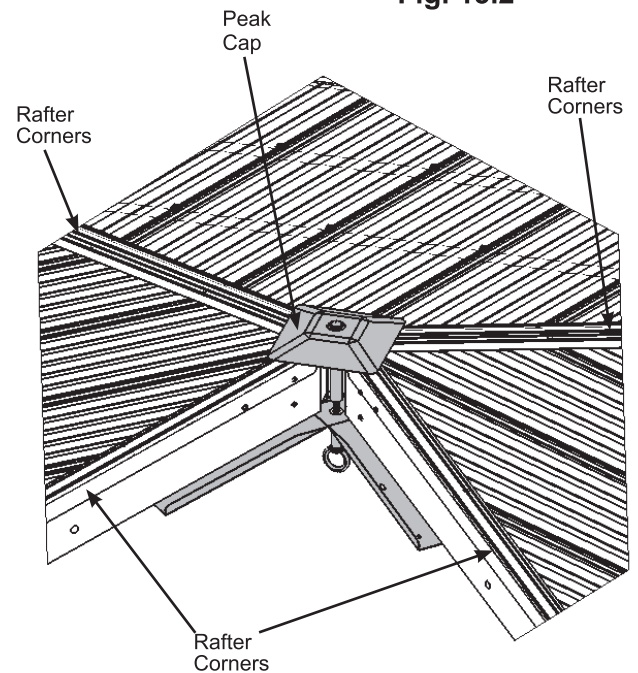
**B:** Insert both Roof Peak Brackets through Carriage Bolt and attach Peak Loop to Carriage Bolt and twist to tighten loosely.

**C:** Loosely attach both Roof Peak Brackets to the Rafter Corners in the slotted holes with two #10 x 1-1/4" Pan Screws as shown in fig. 13.3.

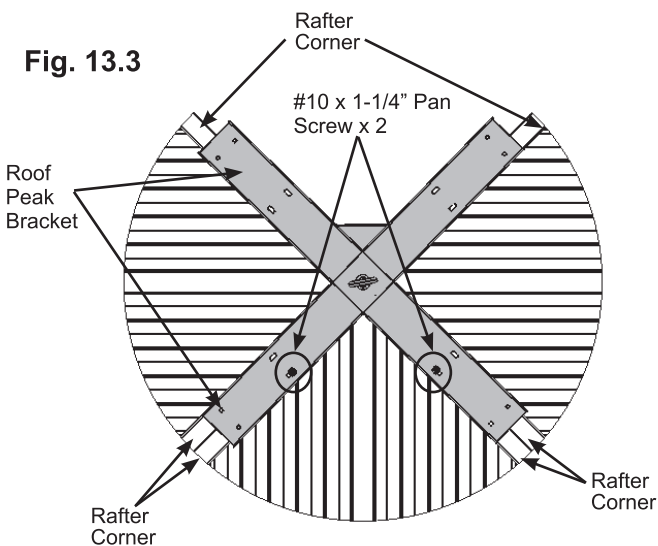
**Fig. 13.1**



**Fig. 13.2**



**Fig. 13.3**



**Components:**

2 x Roof Peak Brackets

**Hardware**

2 x #10 x 1-1/4" Pan Screw

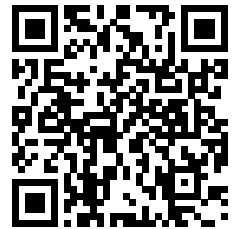
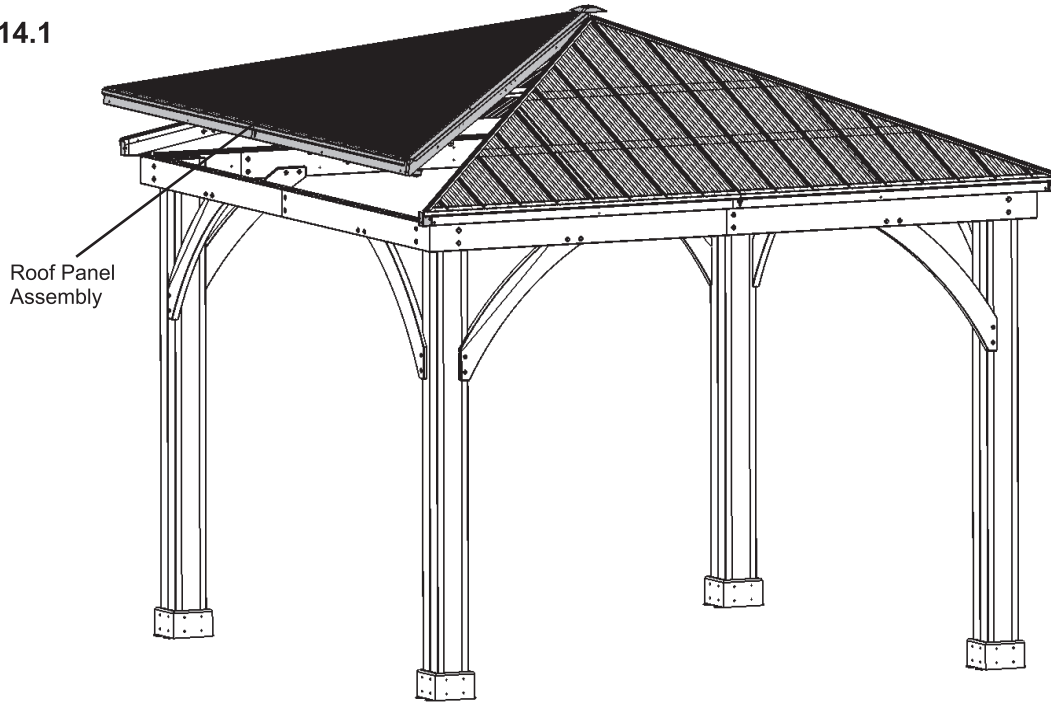
# Step 14: Attach Final Roof Panel Part 1



**A:** Lift last Roof Panel Assembly (without Roof to Beam Brackets) over Beam Assembly taking care not to drag the panel on the beams. Panel fits under the Peak Cap, push up on Peak Loop to lift Peak Cap. The centre of the other panels may have to be pushed up to fit fourth panel. (fig. 14.1 and 14.2)

**B:** Check again that Peak Cap is lined up with Rafter Corners. (fig. 14.3)

Fig. 14.1



<http://bit.ly/1NDtZox>

Fig. 14.2

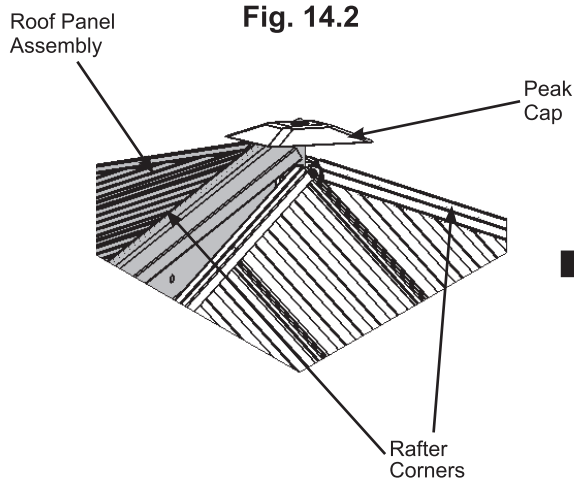
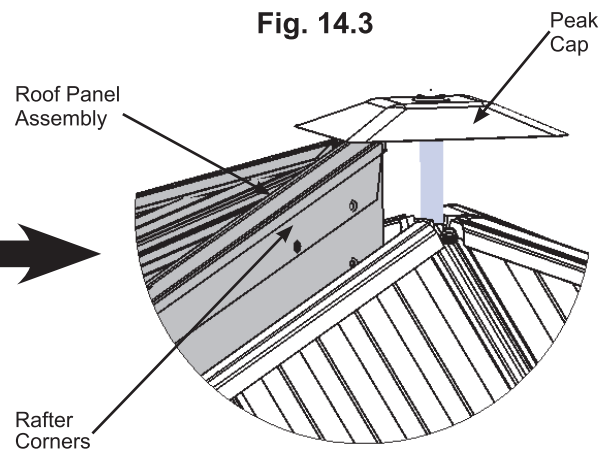


Fig. 14.3





# Step 14: Attach Final Roof Panel Part 2



Remember to push up centre to assist with alignment.

**C:** Starting at the bottom and working up loosely connect Roof Panel Assemblies through the Rafter Corners with three 1/4 x 2-3/4" Hex Bolts (with two 1/4-5/16" large washers and one 1/4" lock nut) per side. To align bolt holes helper on the centre ladder may have to push up in the centre of the panels and others make sure corners are aligned. Tighten bolts when all six have been installed. (fig. 14.4 and 14.5)

*Rafter Corners should be aligned with Roof to Post Bracket.*

Fig. 14.4

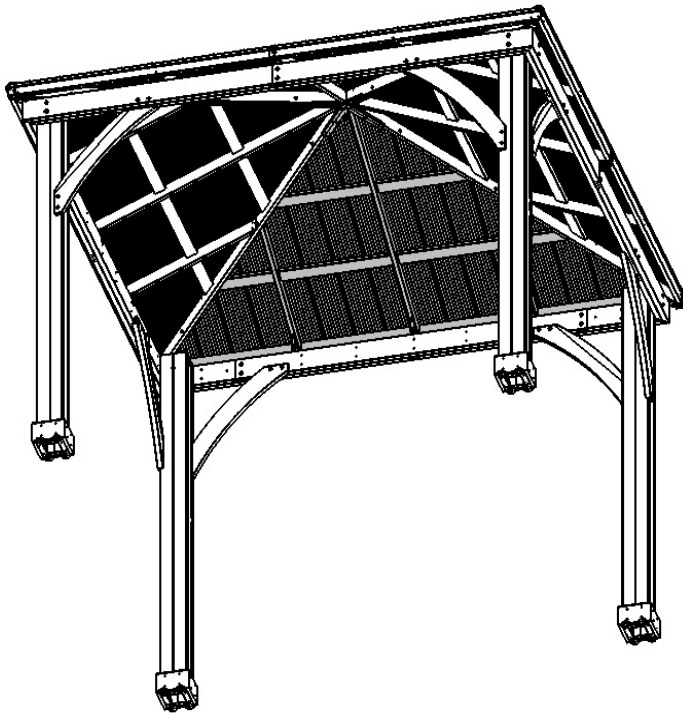
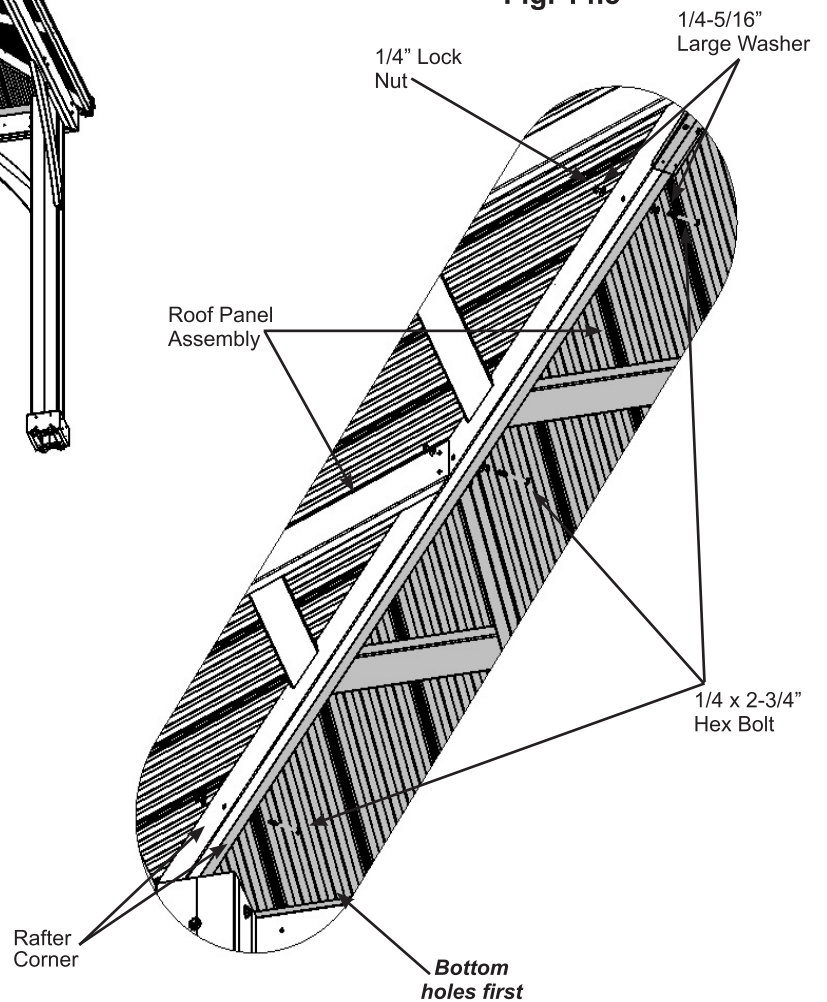


Fig. 14.5



### Hardware

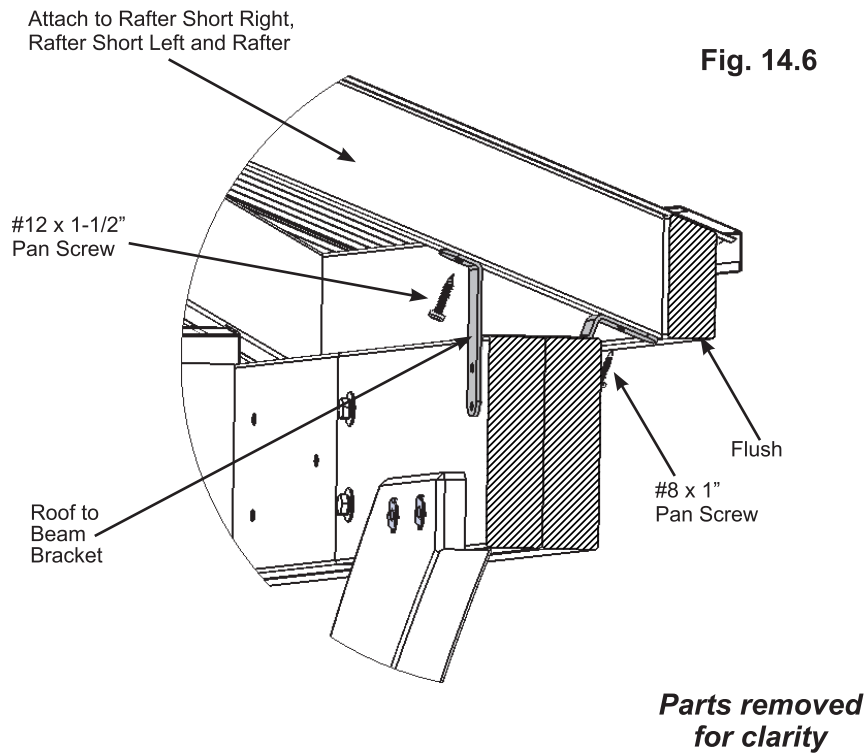
6 x 1/4 x 2-3/4" Hex Bolt  
(1/4-5/16" large washer x 2, 1/4" lock nut)



# Step 14: Attach Final Roof Panel Part 3



**D:** On the fourth Roof Rafter Assembly, centred and flush to the bottom of (338) Rafter Short Right, (339) Rafter Short Left and (340) Rafter attach one Roof to Beam Bracket per board with one #8 x 1" Pan Screw in the bottom hole and one #12 x 1-1/2" Pan Screw in the top hole per bracket. (fig. 14.6)



### Hardware

- 3 x #8 x 1" Pan Screw
- 3 x #12 x 1-1/2" Pan Screw
- 3 x Roof to Beam Bracket

# Step 15: Secure Roof Corners



**A:** Make sure middle Roof to Beam Brackets are lined up over centre mark and all are flush and tight to the Beam Assemblies. Lift in centre if needed.

**B:** From outside the assembly attach Roof Panel Assemblies together at the Fascia Beam Assembly Ends with two #8 x 2-1/2" Wood Screws per corner. A helper may need to lift the centre of the roof to bring the corners tight together. (fig. 15.1 and 15.2)

**C:** Align Roof Panel Assemblies to sit centred on Roof to Post Brackets then attach with two #8 x 1" Pan Screws per bracket. (fig. 15.3)

Fig. 15.1

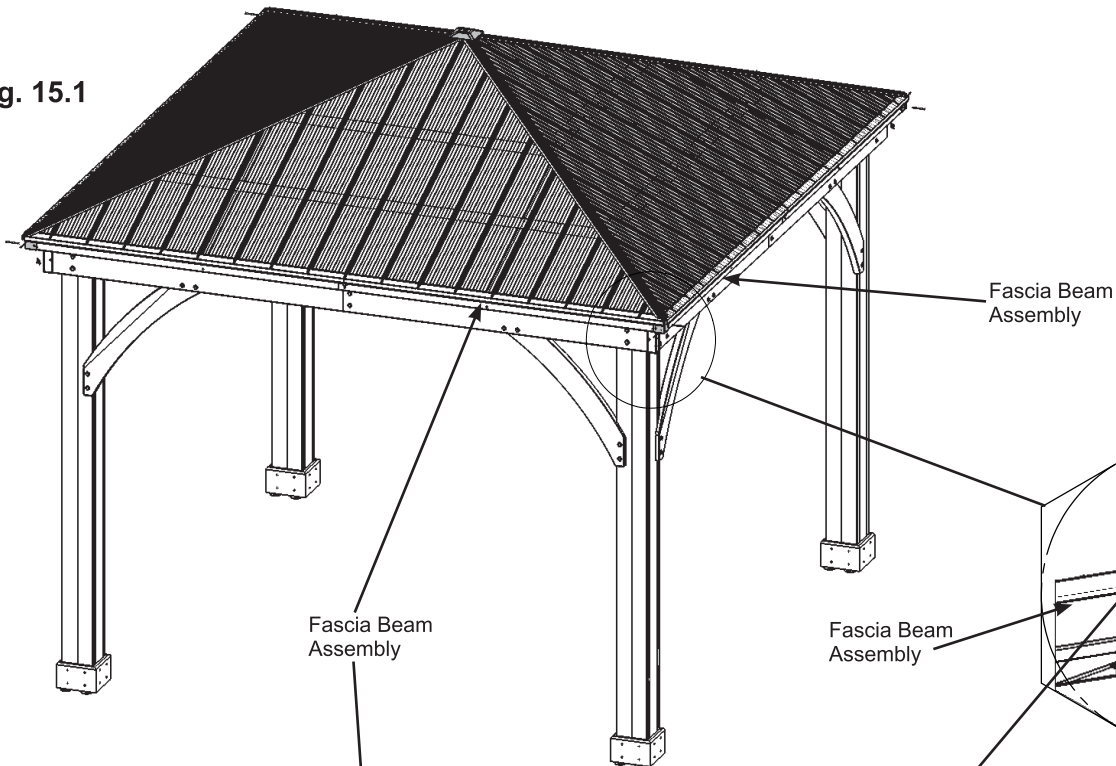


Fig. 15.2

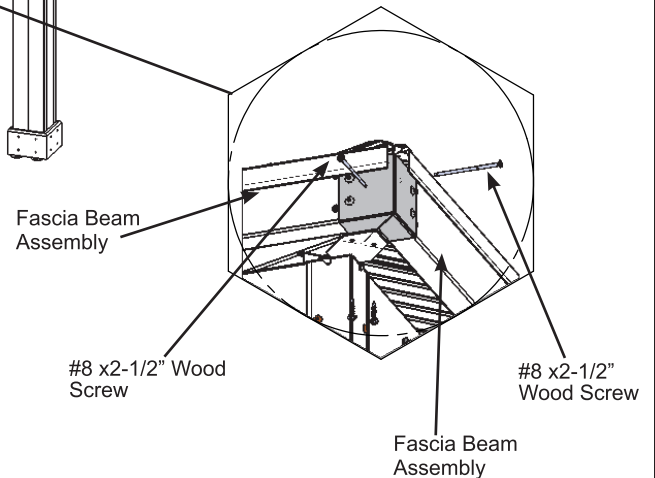
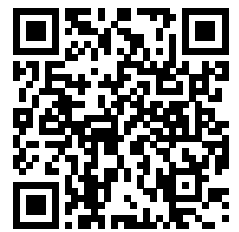
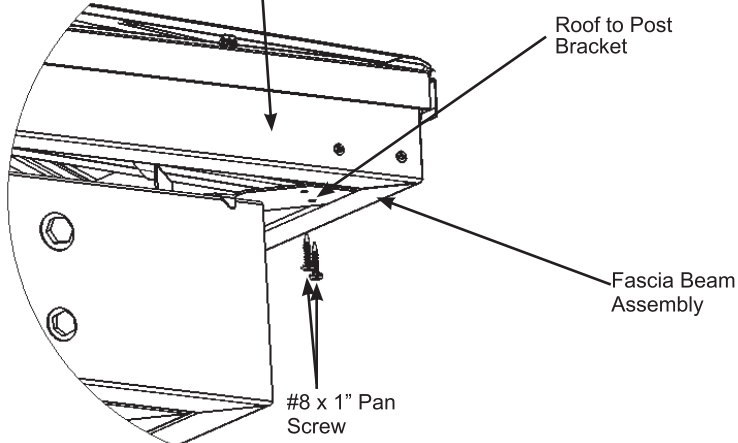


Fig. 15.3



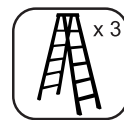
<http://bit.ly/1NDtZox>

## Hardware

8 x #8 x 2-1/2" Wood Screw

8 x #8 x 1" Pan Screw

# Step 16: Attach Corner and Beam Caps



**A:** At each corner place one Corner Cap tight to Fascia Assemblies, push up so the bottom is tight to the bottom of the assemblies then attach with four #8 x 3/4" Sheet Metal Screws per Corner Cap. (fig. 16.1 and 16.2)

Fig. 16.1

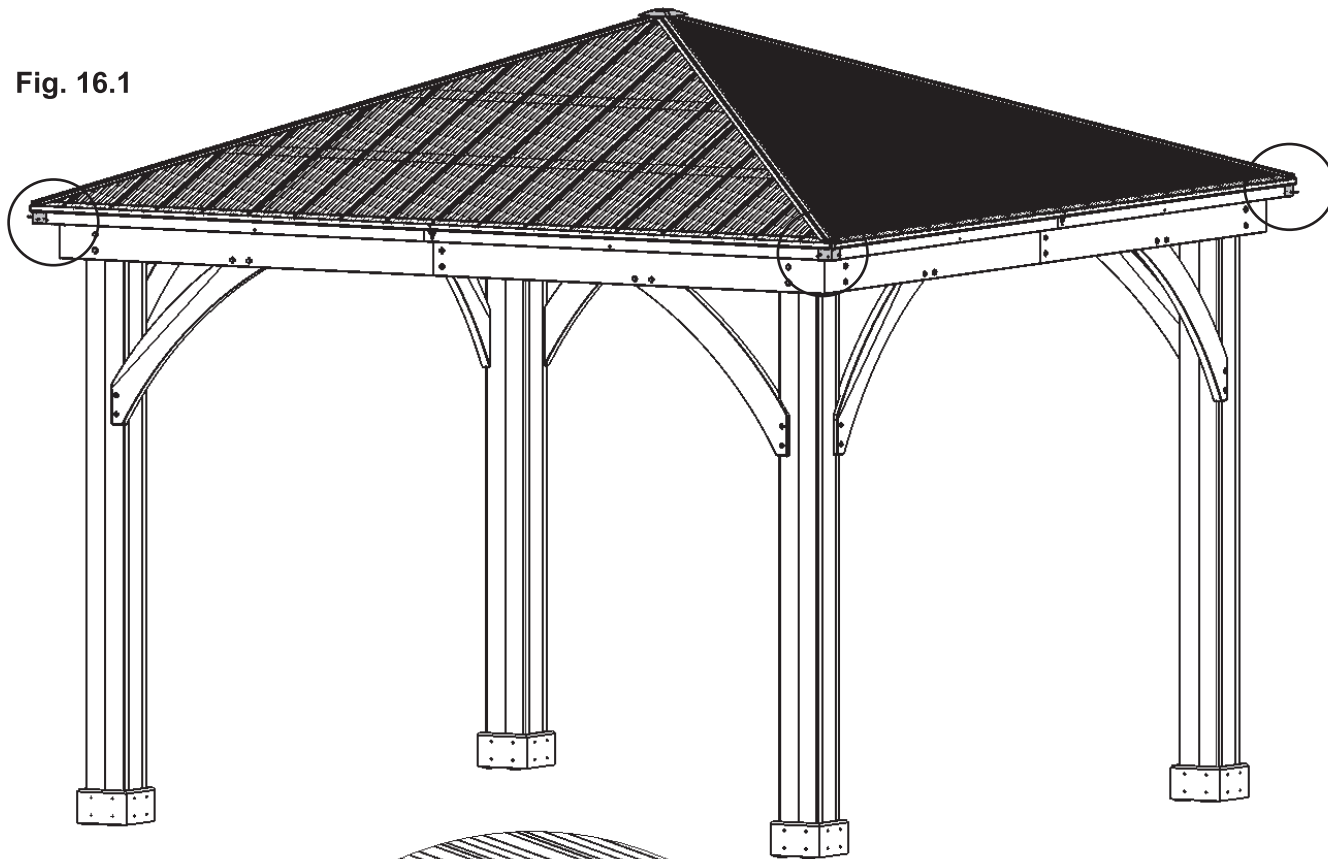
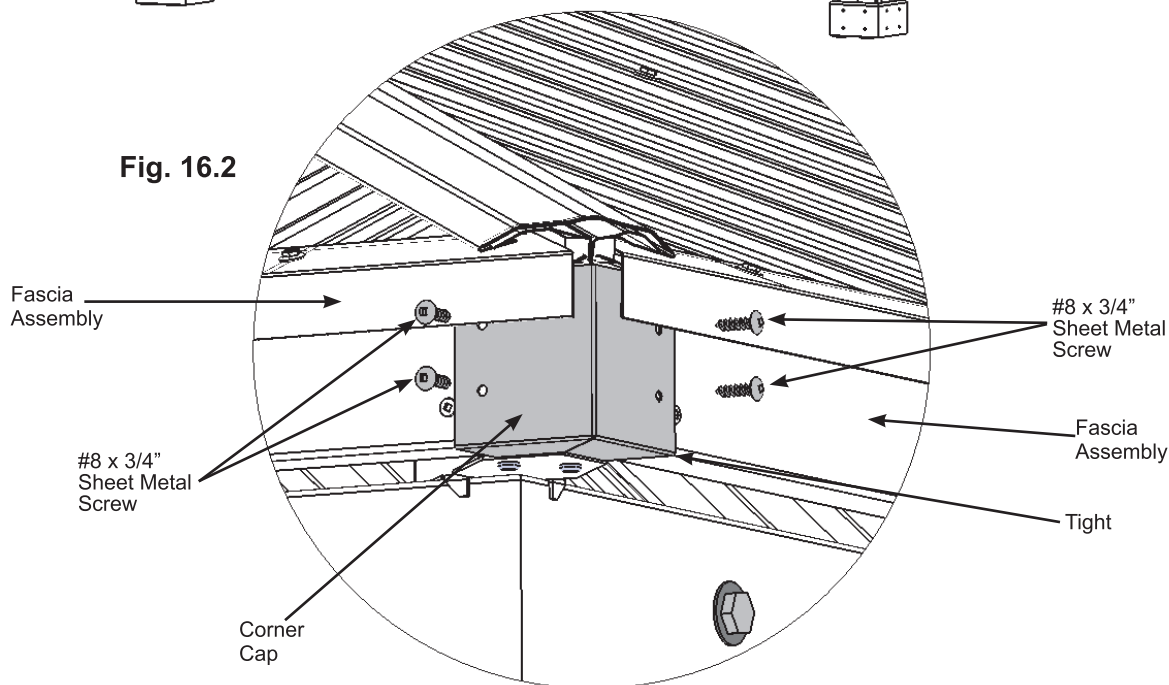


Fig. 16.2



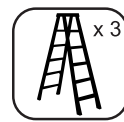
**Components:**

4 x Corner Cap

**Hardware**

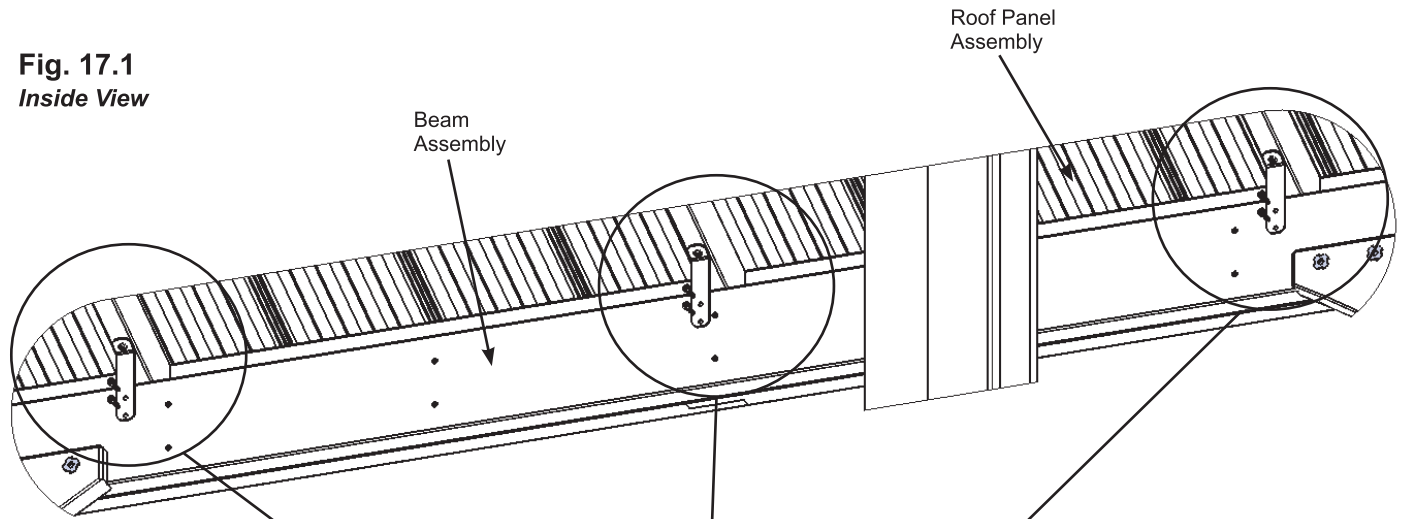
16 x #8 x 3/4" Sheet Metal Screw

# Step 17: Secure Roof to Beam Brackets

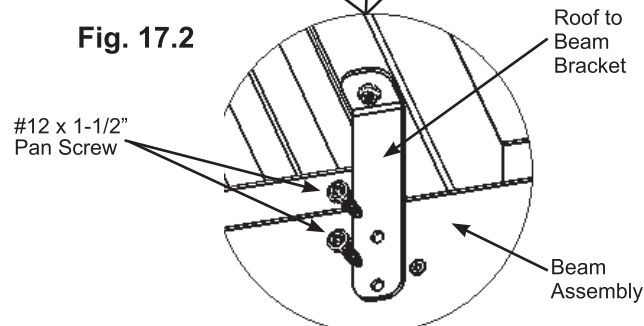


**A:** From inside the assembly attach Roof to Beam Brackets to Beam Assemblies with two #12 x 1-1/2" Pan Screws per bracket. (fig. 17.1 and 17.2)

**Fig. 17.1**  
*Inside View*



**Fig. 17.2**



**Hardware**

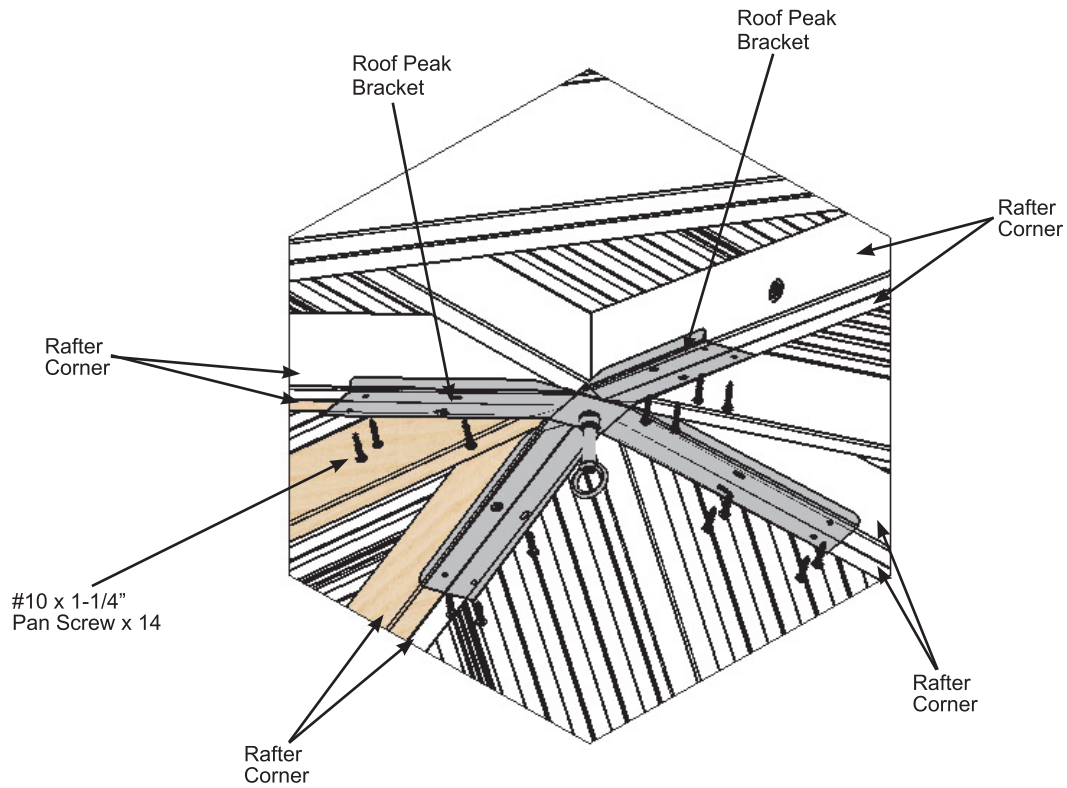
24 x #12 x 1-1/2" Pan Screw

# Step 18: Secure Roof Peak Brackets



**A:** Tighten the two screws in Roof Peak Brackets then attach to Corner Rafters in the remaining holes with fourteen #10 x 1-1/4" Pan Screws. (fig. 18.1)

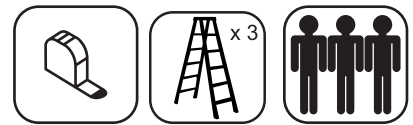
**Fig. 18.1**



**Hardware**

14 x #10 x 1-1/4" Pan Screw

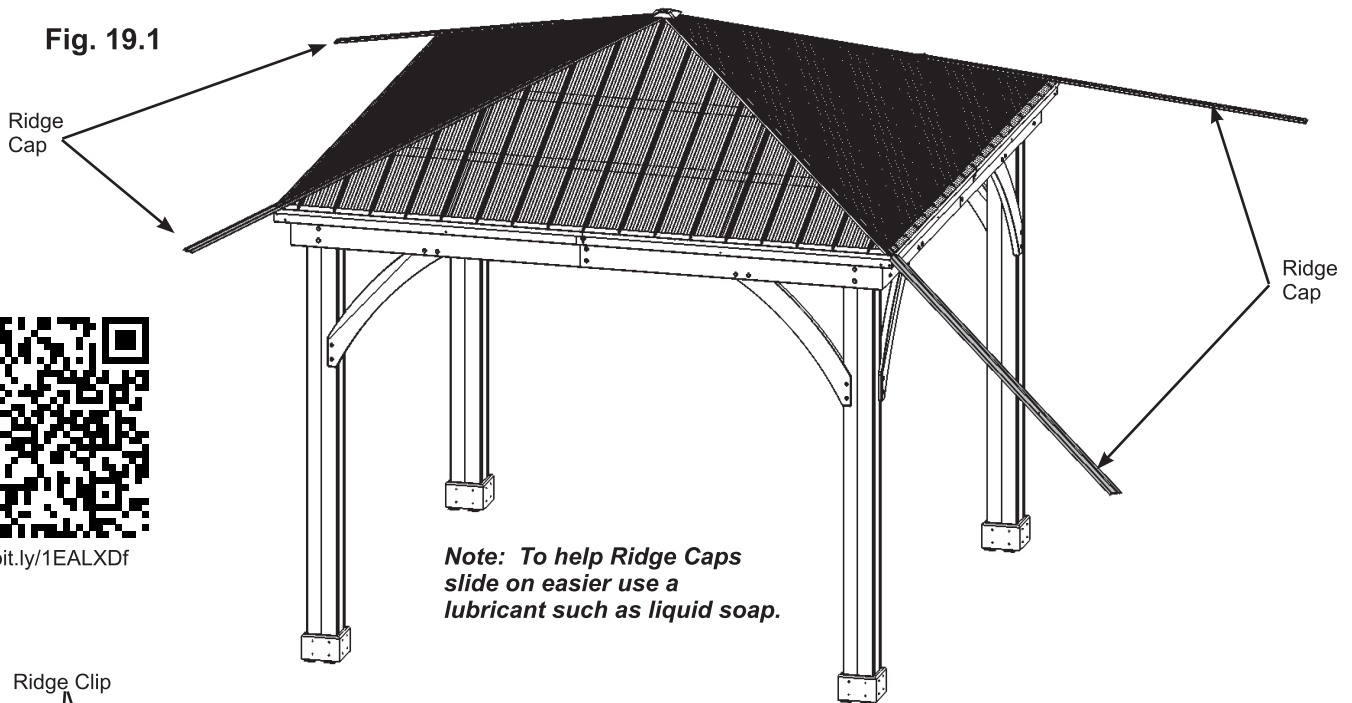
# Step 19: Attach Ridge Caps to Roof Panels



**A:** Slide one Ridge Cap over the Ridge Clips, with cut end leading, on each corner of the assembly from the bottom up, lifting Peak Cap by pushing up the Peak Loop so Ridge Caps fit under Peak Cap then attach with two #8 x 3/4" Sheet Metal Screws per Ridge Cap. (fig. 19.1, 19.2 and 19.3)

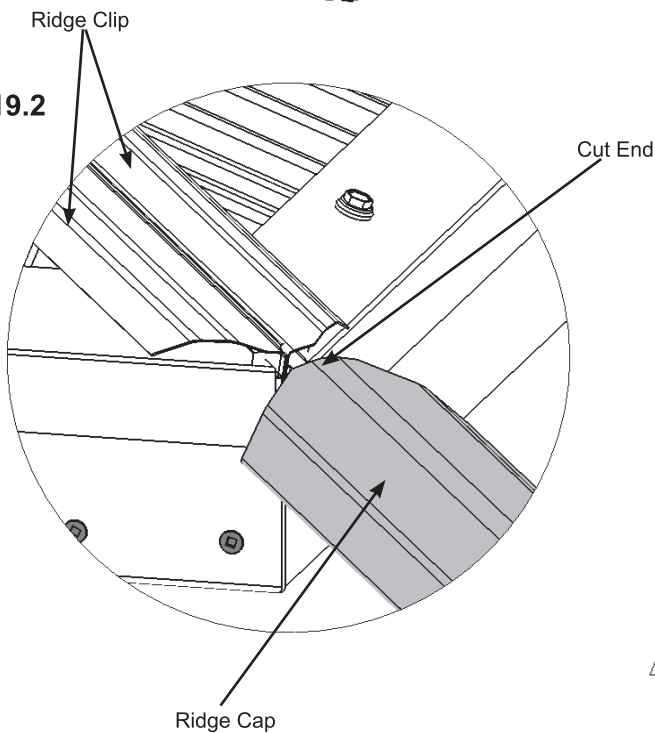
**B:** Tighten Loop to secure Roof Peak Set.

**Fig. 19.1**

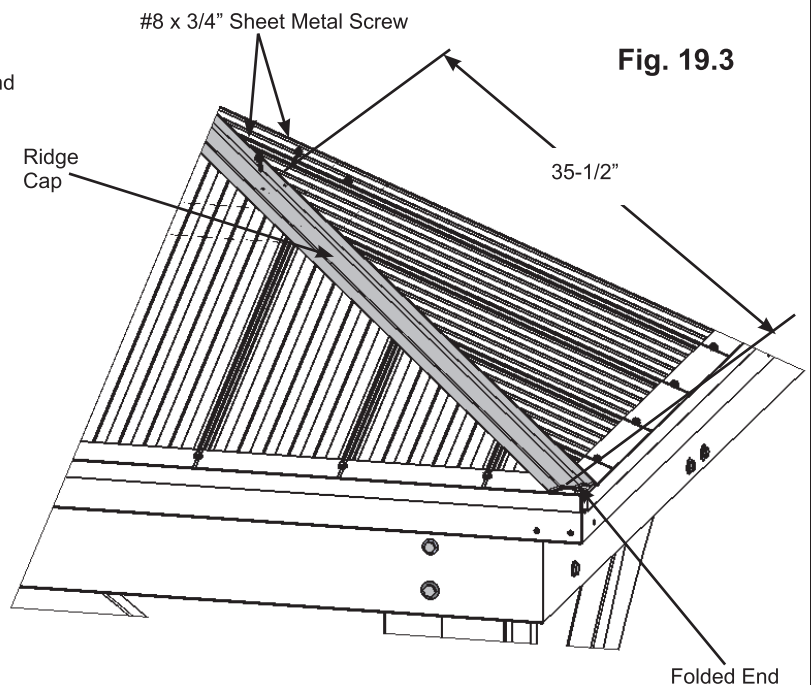


<http://bit.ly/1EALXDf>

**Fig. 19.2**



**Fig. 19.3**



**Components:**

4 x Ridge Cap

**Hardware**

8 x #8 x 3/4" Sheet Metal Screw

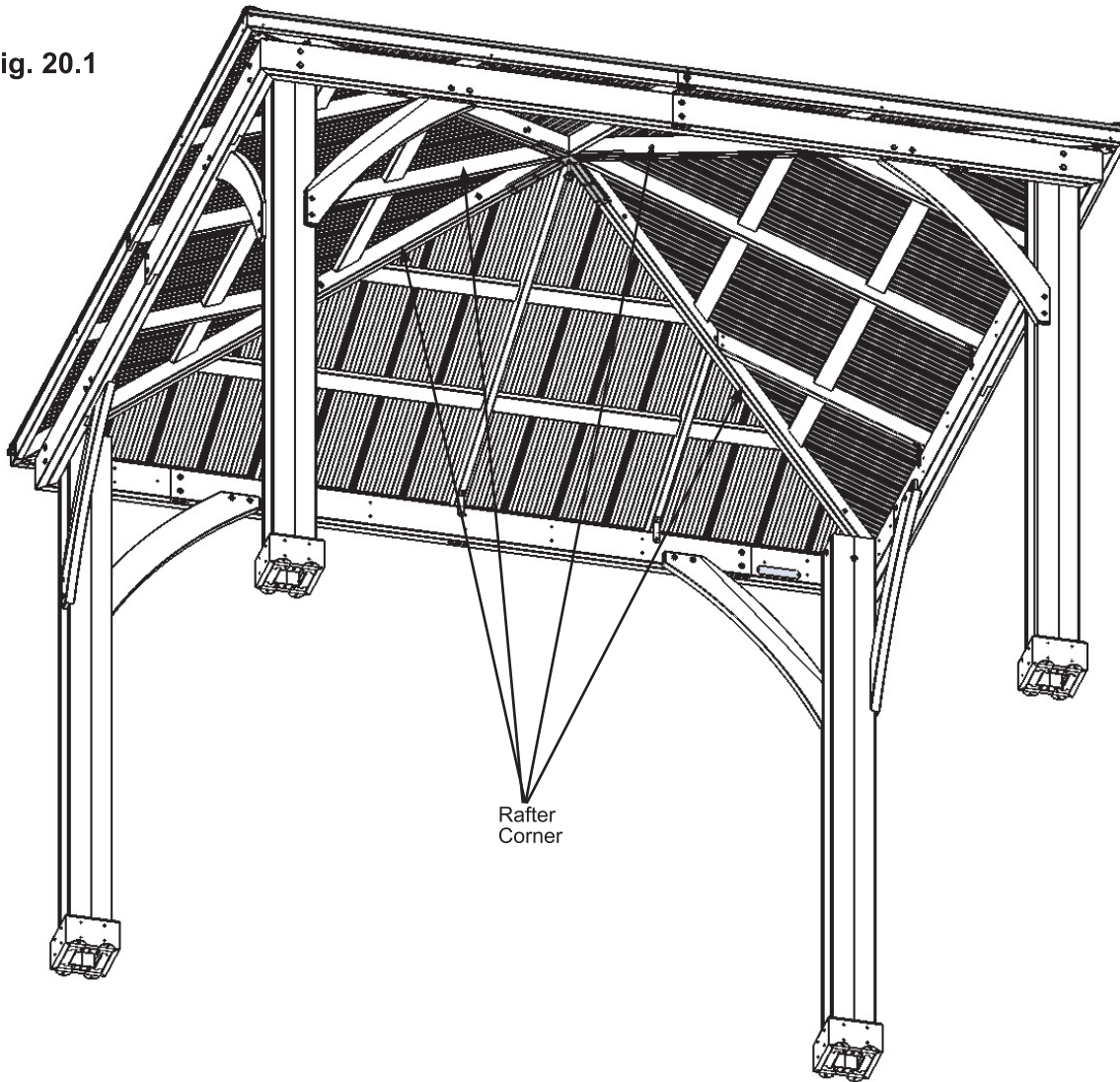


# Step 20: Metal Hooks and Plaque Part 1



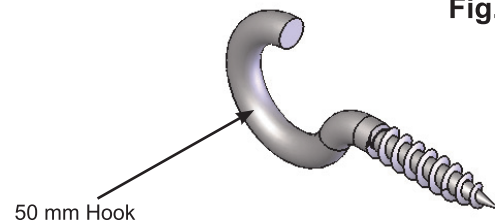
**A:** Two 50 mm Hooks are included with this unit for attaching wiring. They can be placed anywhere along the Rafter Corners as needed. Pre-drill with a 1/8" drill bit before installing. (fig. 20.1 and 20.2)

Fig. 20.1



**Note:** We have provided 2 hooks for optional use to hold in place any wires if required. These hooks are not designed to hold any heavy products such as lights, flower pots, etc.

Fig. 20.2



### Hardware

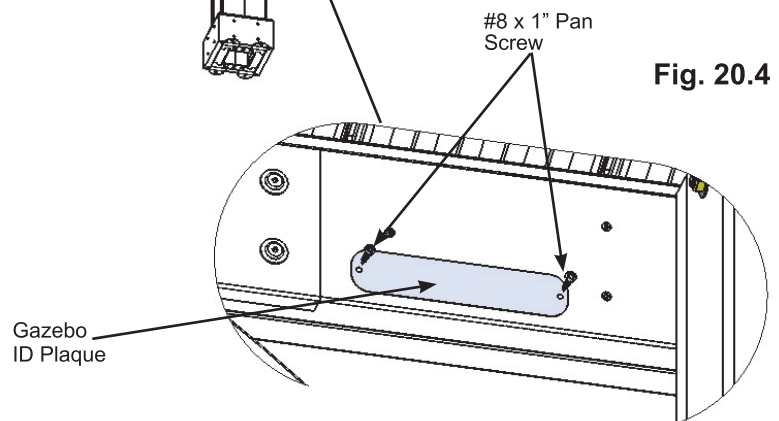
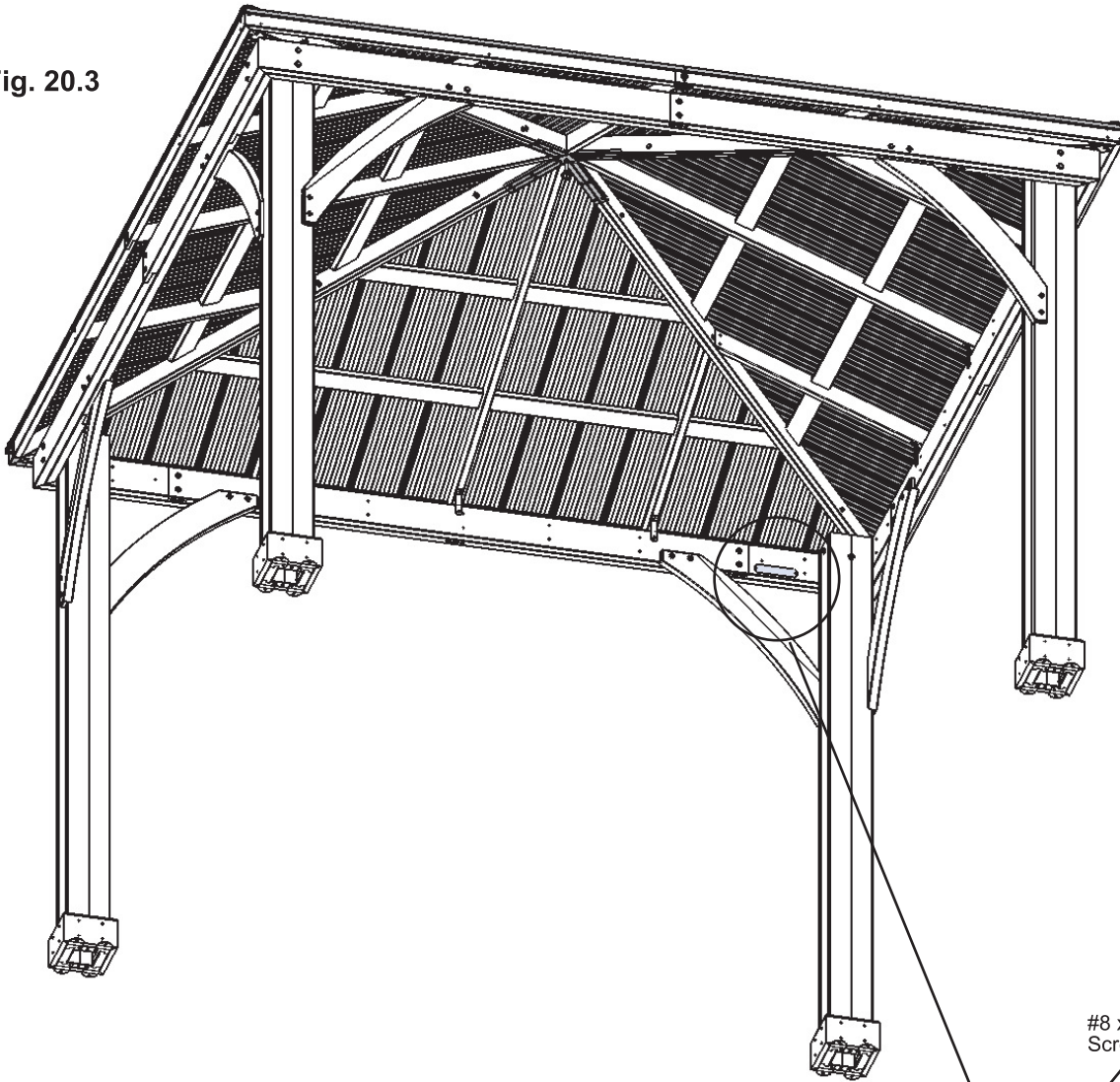
2 x 50 mm Hooks



## Step 20: Metal Hooks and Plaque Part 2

**B:** Attach Gazebo ID Plaque to a prominent location on your gazebo with two #8 x 1" Pan Screws. This provides warnings concerning safety and important contact information. A tracking number is provided to allow you to get critical information or order replacement parts for this specific model. (fig. 20.3 and 20.4)

Fig. 20.3



### Hardware

2 x #8 x 1" Pan Screw

1 x Gazebo ID Plaque





# YARDISTRY

## Consumer Registration Card

First Name

Initial

Last Name

Street

Apt. No.

City

State/Province ZIP/Postal Code

Country

Telephone Number

E-Mail Address

Model Name

Model Number

(Box Labels)

Date Purchase

Purchased From

MM / DD / YYYY

How would you rate this product for quality?

Excellent

Very Good

Average

Below Average

Poor

How would you rate this product for ease of assembly?

Excellent

Very Good

Average

Below Average

Poor

How would you rate our instructions?

Excellent

Very Good

Average

Below Average

Poor

How would you rate the quality of packaging?

Excellent

Very Good

Average

Below Average

Poor

Would you recommend the purchase of our products to friends and family?

Yes

No

Comments:

---

---

---

MAIL TO:

Yardistry

375 Sligo Road W., PO Box 10

Mount Forest, Ontario, Canada

NOG 2L0

Attention: Customer Service

# YARDISTRY®

Yardistry would like to say Thank You for your time and feedback.

